

# Collector Ring @ FAIR Facility Status and Perspectives

Yu. A. Rogovsky  
on behalf of BINP and GSI team

10 Oct 2014, Obninsk, RuPAC-2014

# FAIR complex project

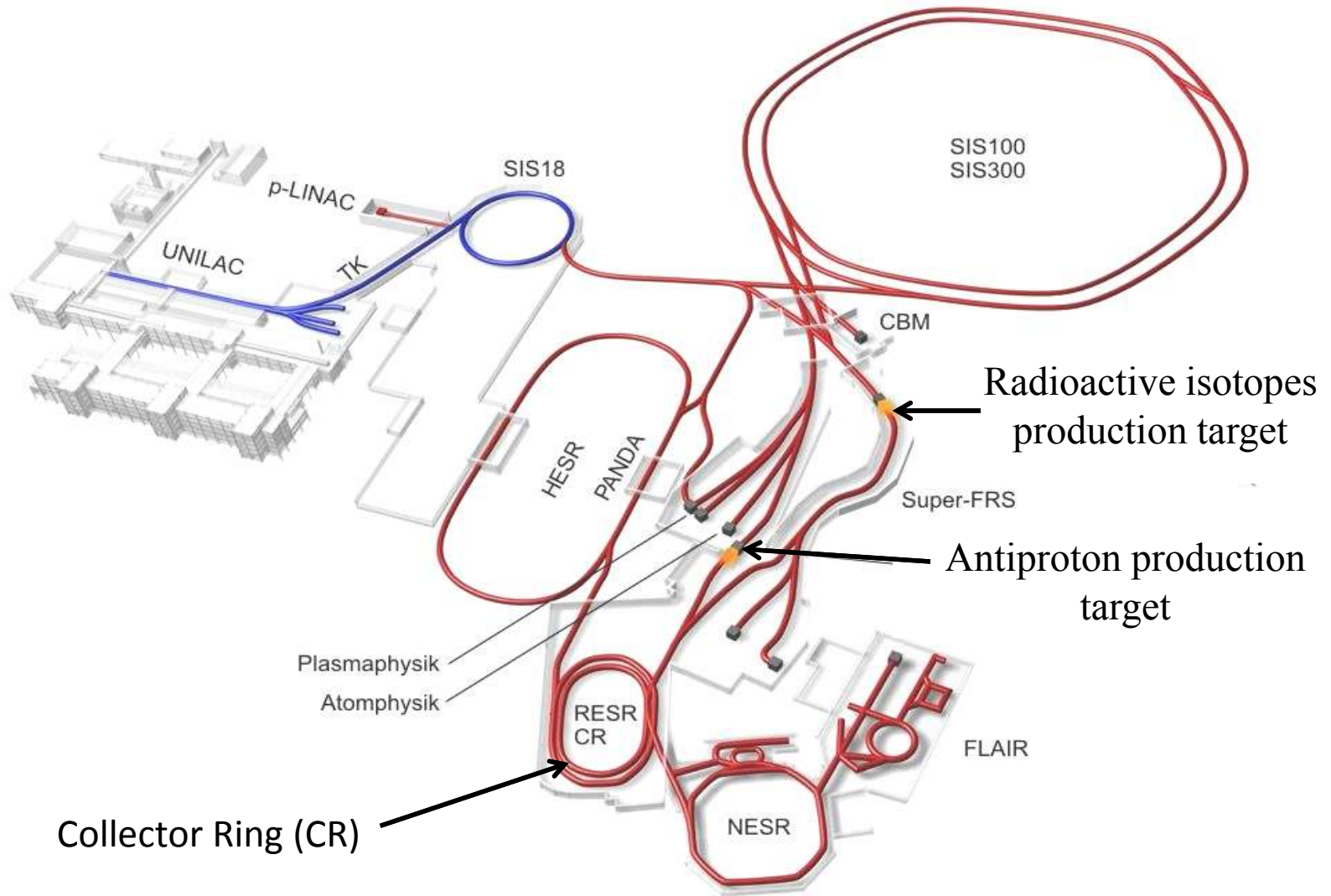

Collector Ring is a synchrotron for capture and cooling of secondary beams.

# Collaboration Contract FAIR - BINP

Budker Institute of Nuclear Physics –  
Technical Coordinator of CR construction



# Collector Ring tasks

## 1. Cooling of antiproton beams, (“pbar”)

From antiproton separator

$$\begin{aligned} \varepsilon_{\perp} &= 240 \text{ mm mrad} \\ \Delta p/p &= \pm 3 \% \end{aligned}$$

CR

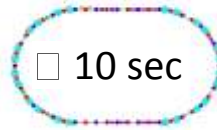

$$\begin{aligned} \varepsilon_{\perp} &\leq 5 \text{ mm mrad} \\ \Delta p/p &\leq \pm 0.05 \% \end{aligned}$$

to the HESR

## 2. Cooling of secondary beams of radioactive ions, (“RIB”)

From Super-FRS

$$\begin{aligned} \varepsilon_{\perp} &= 200 \text{ mm mrad} \\ \Delta p/p &= \pm 1.5 \% \end{aligned}$$

CR

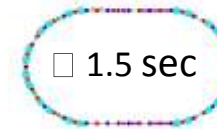

$$\begin{aligned} \varepsilon_{\perp} &\leq 0.5 \text{ mm mrad} \\ \Delta p/p &\leq \pm 0.025 \% \end{aligned}$$

to the RESR

## 3. Mass spectrometer of radioactive ions (TOF), (“isochronus”)

From Super-FRS

$$\begin{aligned} \varepsilon_{\perp} &= 100 \text{ mm mrad} \\ \Delta p/p &= 1 \% \end{aligned}$$

CR

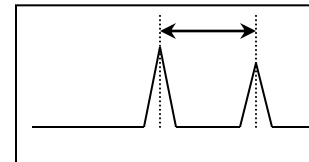
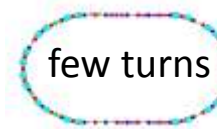

$$\frac{\Delta}{m} = \gamma \frac{\Delta}{f}$$

# Beams from separators

29 GeV protons from SIS100

740 MeV/u RIBs

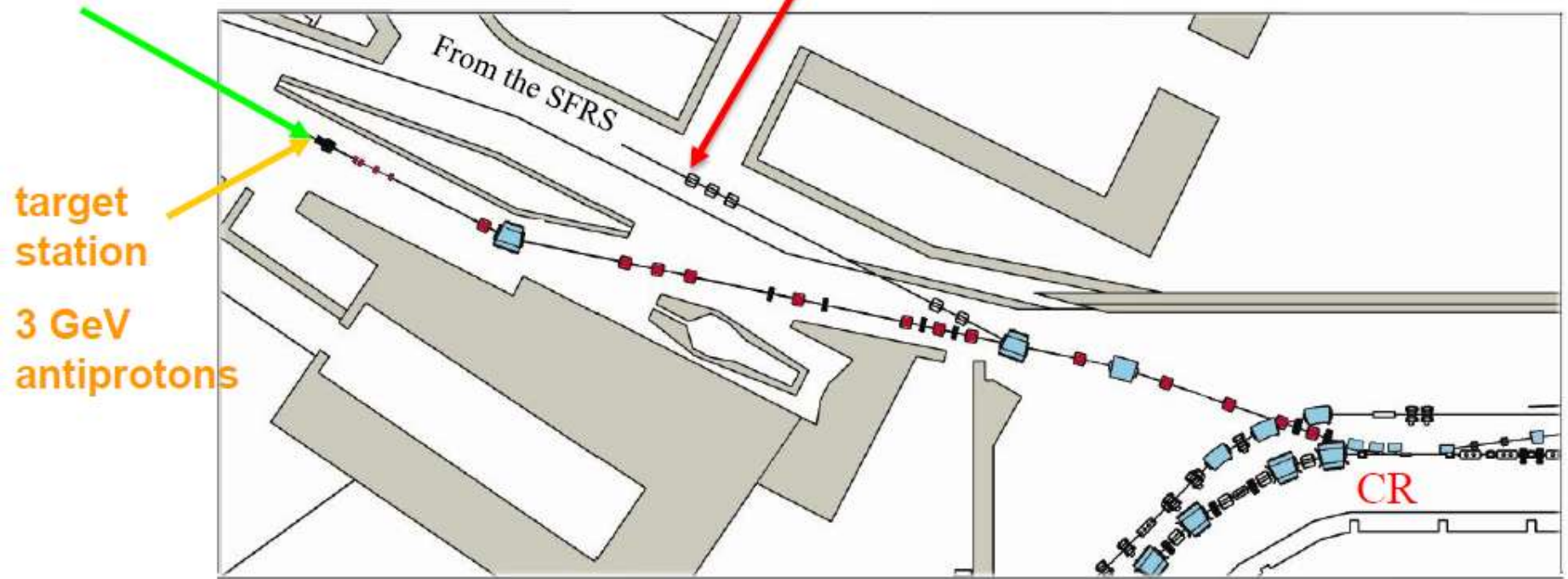

3 GeV antiprotons

# Antiprotons production

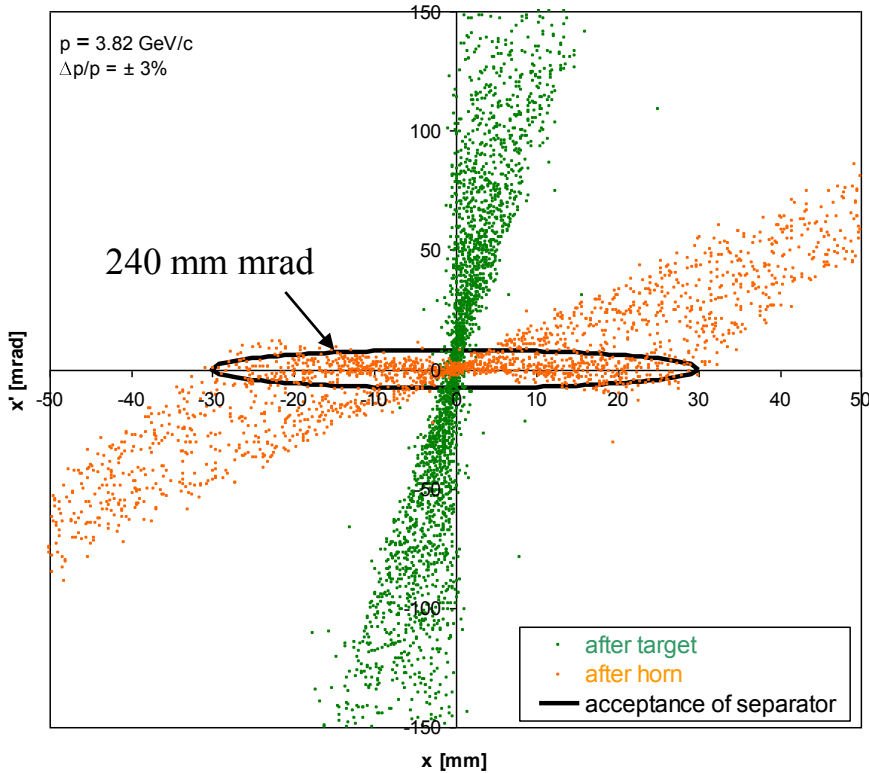

Less than 7 % of produced particles on the target can be accepted by the pbar separator and the CR

Pbar production rate (simulations):  $2 \cdot 10^{-5}$  pbar/p  
 For  $10^{13}$  proton one gets  $2 \cdot 10^8$  pbars

11 cm Ni target ( $d = 3$  mm) in a graphite container, 0.62 mm (rms) beam spot.

From SIS-100

E(p), E(pbar)	29 GeV, 3 GeV
acceptance	240 mm·mrad, $\pm 3\%$
protons / pulse	$\geq 2 \cdot 10^{13}$
pulse length	single bunch (50 ns)
cycle time	10 s

# Collector Ring layout

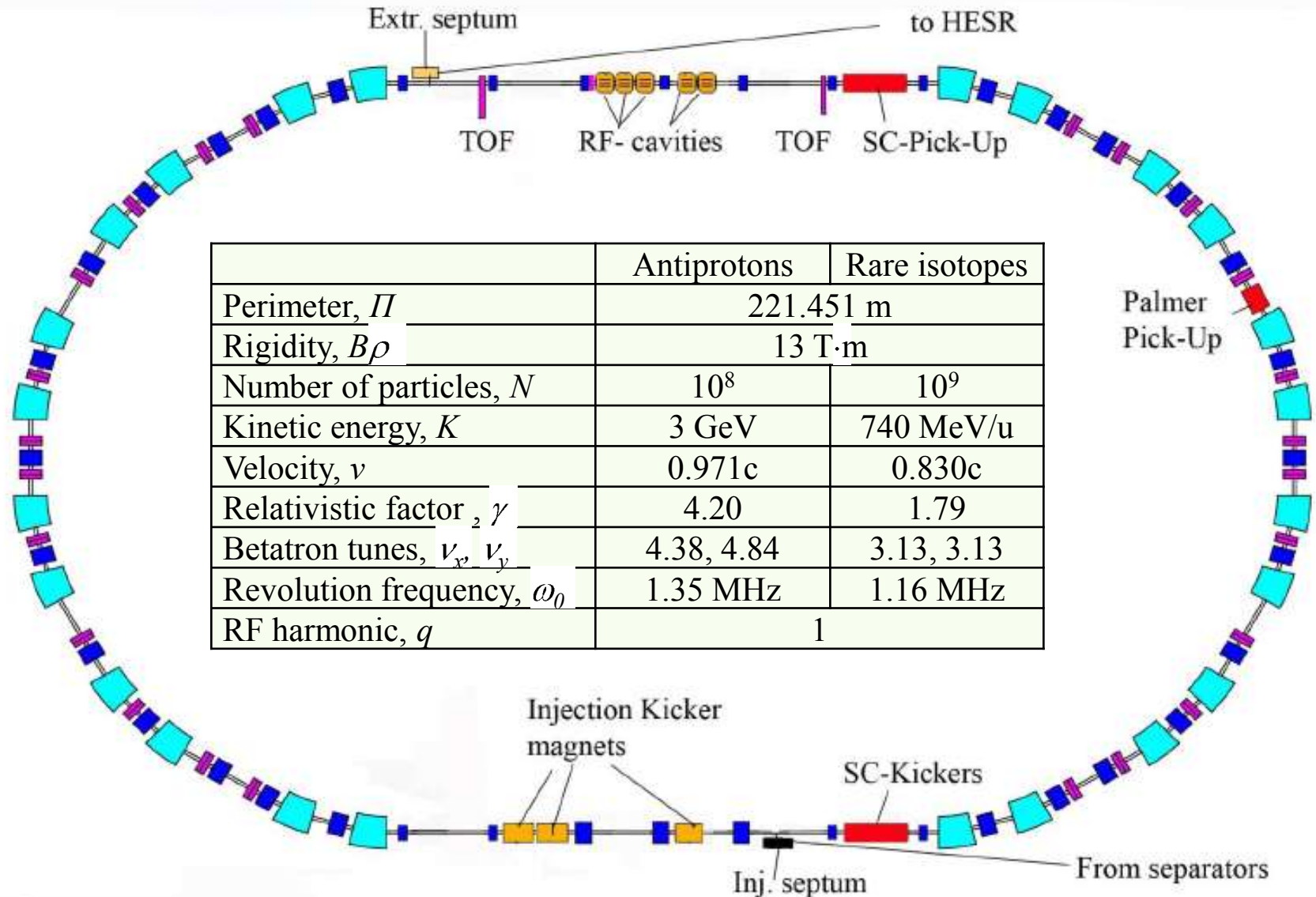

# Collector Ring layout (upgrade)

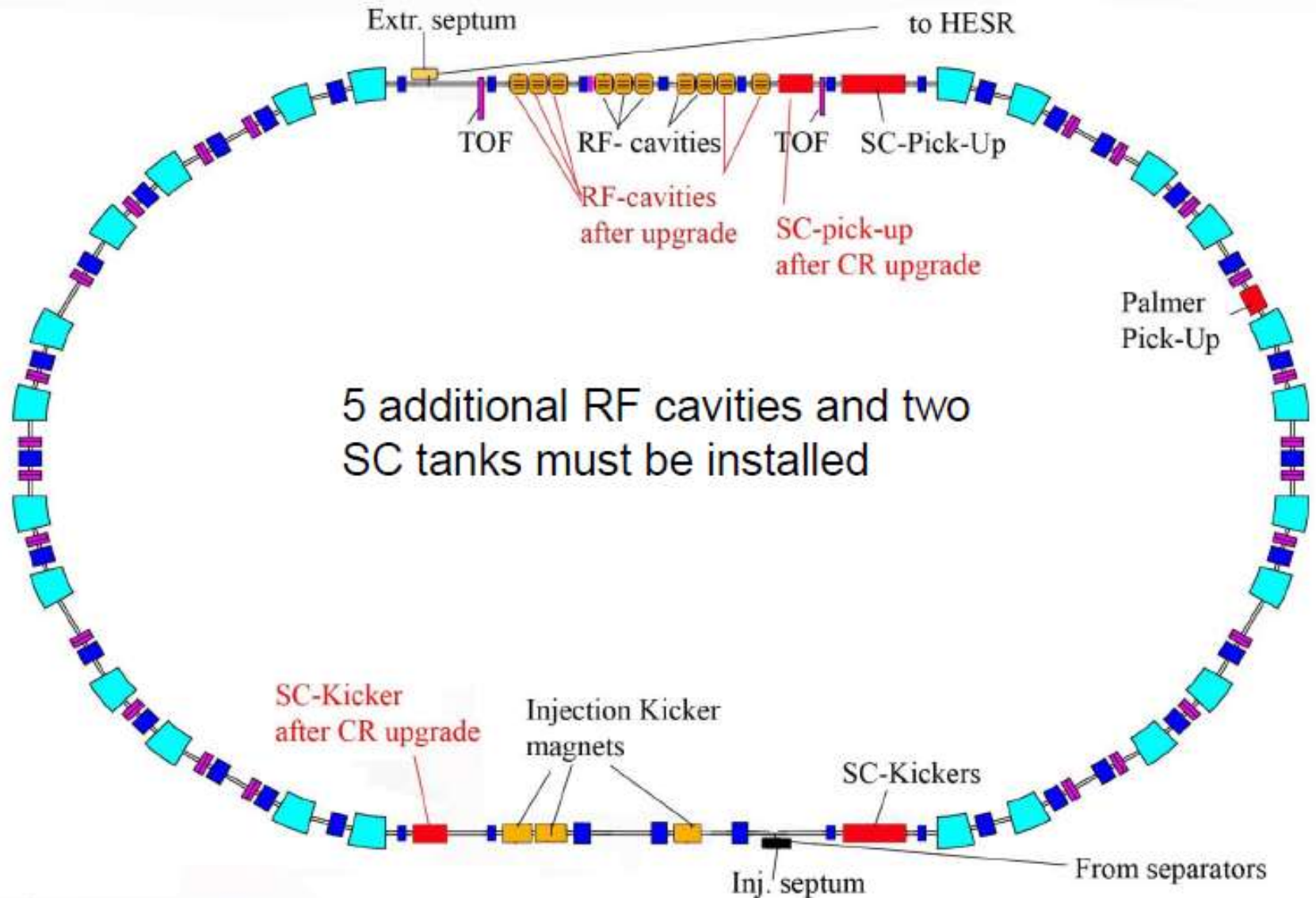



# Cooling (1 step) – RF bunch rotation

Using bunch rotation RF cavity the momentum spread is reduced by factor of 3  
 P-bars (from 6% to less than 2%)  
 RIBs (from 3% to less than 1%)  
 Time of such cooling is about 3 ms

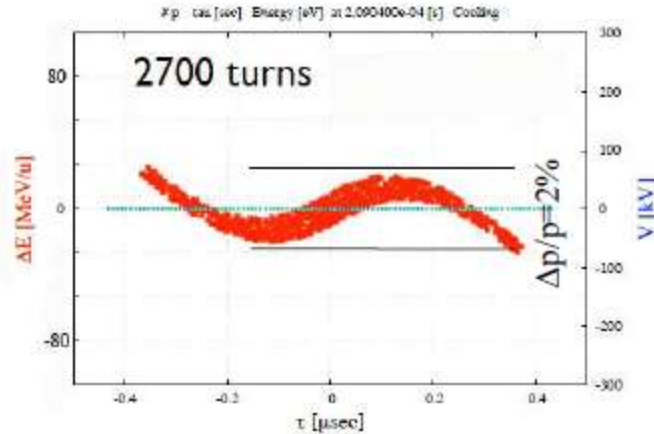
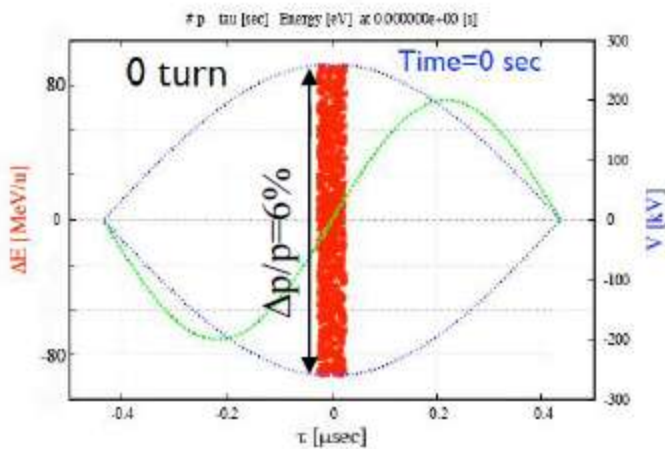

Preliminary sketch of cavity/amplifier



Length (flange to flange): 1m  
 Width: 850mm  
 Total height: 2100mm

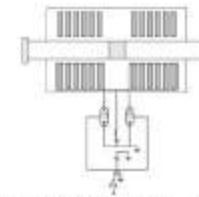

- Two inductively loaded coaxial quarter wave length resonators operating on a common gap
- Six ring cores per cavity half (total of 12)
- Forced air cooling of cavity
- Change of resonator frequency by means of variable capacitors
- Inductive coupling of amplifier to cavity
- Push-pull amplifier consisting of two sections



Existing SIS18 bunch compression cavity. The design of the CR DB will be very similar to this cavity.

Total voltage (5 cavities)	<b>200 kV</b>
Peak voltage per cavity	<b>40 kV</b>
Peak dissipation per valve	393 kW
Peak dissipation per valve into ring cores	648 kW
Peak power per valve	1040 kW

# Cooling (2 step) - Stochastic cooling

After bunch rotation Stochastic cooling is applied to reduce both the beam emittance and momentum spread

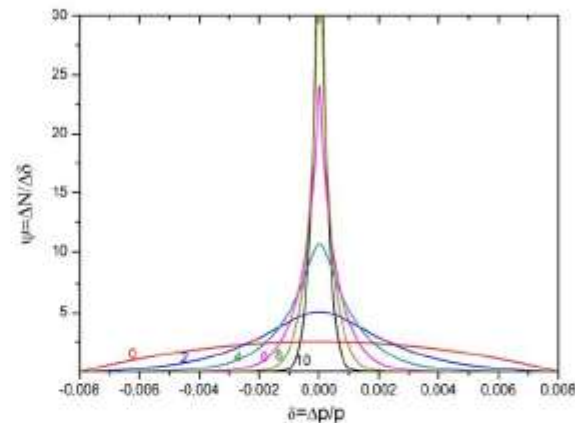
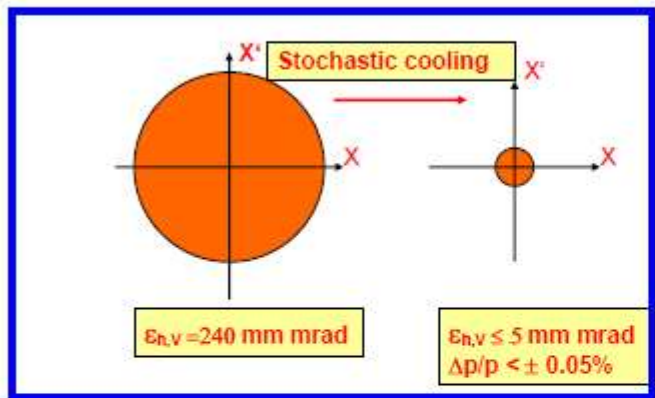

Pbar : Momentum spread - from 2% to 0.1%  
Emittance - from 240 to 5 mm mrad  
Cooling time - 10 seconds

RIBs: RIB momentum spread from 1 % to 0.05 %  
Emittance from 200 to 0.5 mm mrad (time 1.5 seconds)  
Cooling time - 1.5 sec

# TOF mass measurements

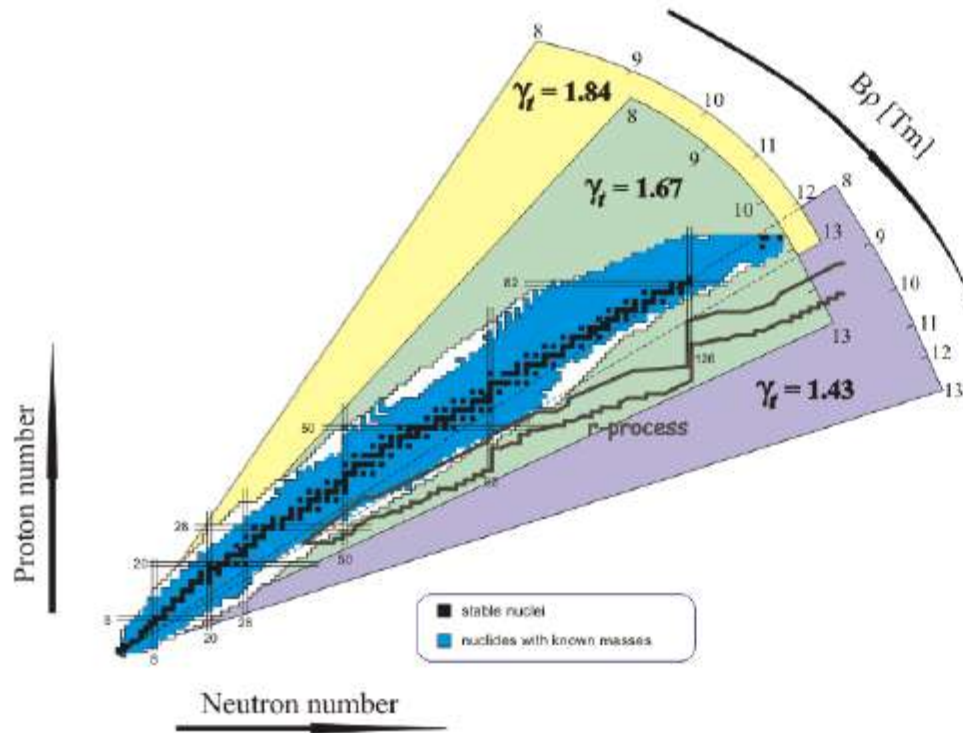

$$\frac{\Delta f}{f} = -\frac{1}{\gamma_{tr}^2} \frac{\Delta(m/q)}{m/q} + \left(1 - \frac{\gamma^2}{\gamma_{tr}^2}\right) \frac{\Delta v}{v} + \left(\frac{\delta f}{f}\right)_{error}$$

Isochronous mode ( $\gamma_{tr} = \gamma$ ) is required for fast mass measurements.

1.  $\gamma_{tr} = \gamma = 1.84$  ( $E = 782.5$  MeV/u)
2.  $\gamma_{tr} = \gamma = 1.67$  ( $E = 624.1$  MeV/u)
3.  $\gamma_{tr} = \gamma = 1.43$  ( $E = 400.5$  MeV/u)

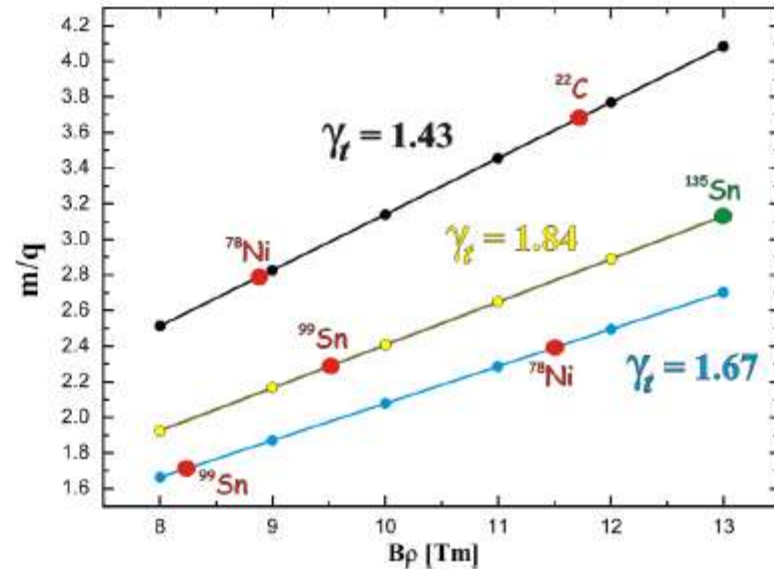

# Operation cycle for pbar/rib

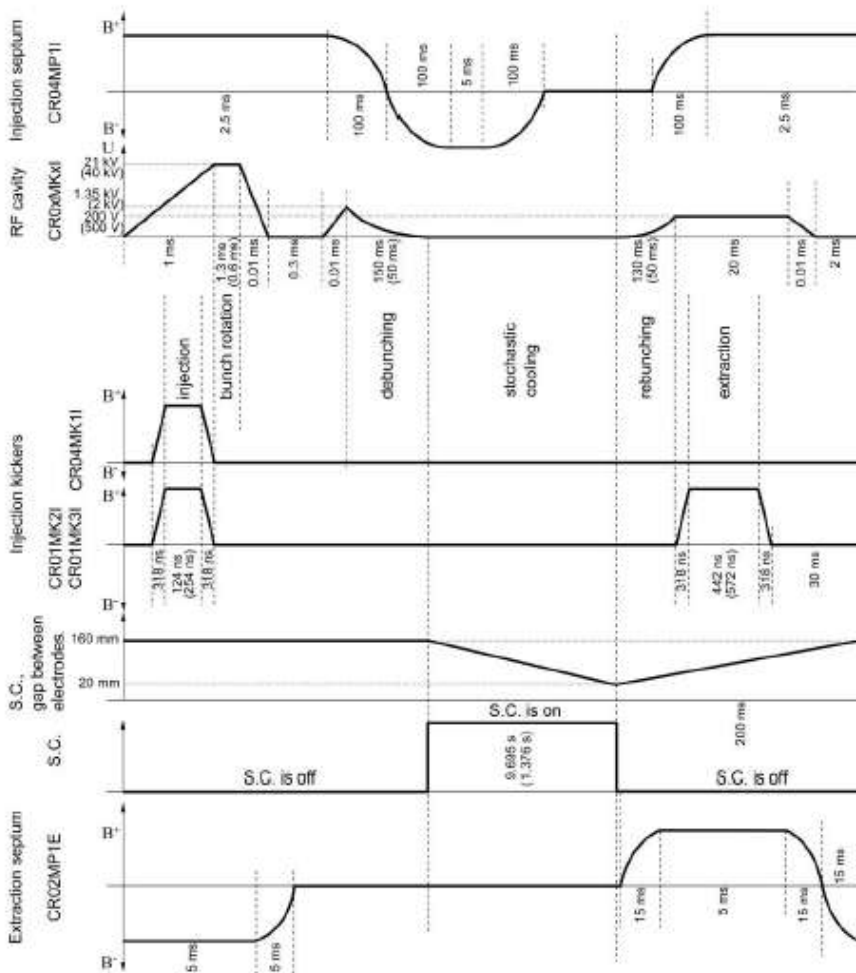

## CR cycle

The operation cycle of the CR in antiproton and RIB

The other operation modes are still under development and must be defined as well both for stable and unstable ion operation, lower antiproton energy. The ions direct from SIS18 or SIS100 can be injected to the CR and afterward redirected to the HESR for experiment (still under discussion)

# Requirements to the ring

- At least three optics must be prepared
- Efficient stochastic cooling for two optics
- Large ring acceptance
- Injection/Extraction should guarantee large ring acceptance
- Good magnet field quality to perform mass measurements with high accuracy
- High power RF system

# Stochastic cooling requirements

- High frequency RF system for signal processing
- High impedance and sensitivity electrodes for Pick-Up electrodes
- Dispersion free drift spaces ( $\sim 10\text{m}$ )
- Mixing conditions must be close to ideal (this depends on ring optics)

# CR lattice (pbar mode)

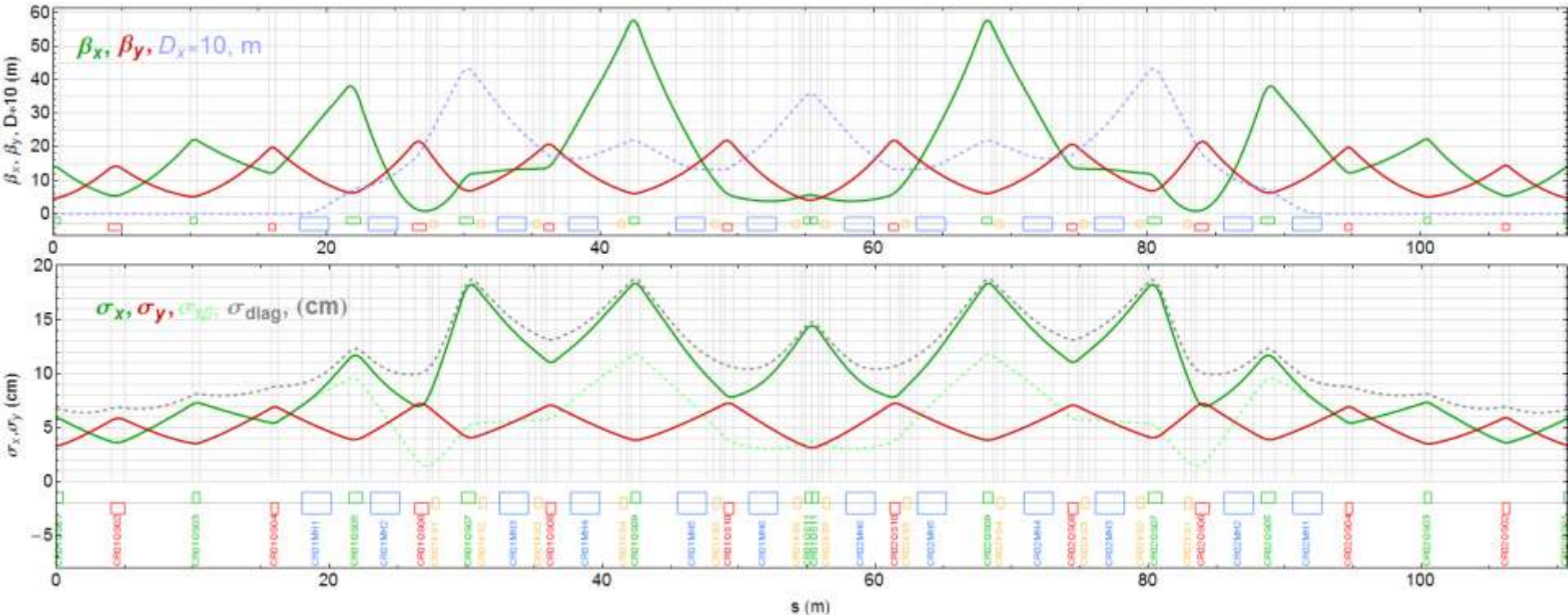

Lattice functions of one half-period.

The ring consists of two arcs and two long dispersion-free straight sections for Stochastic Cooling (SC) components, injection-extraction systems and RF-cavities.

# Proposed antiproton optics changes

- $Q_x=4.18, Q_y=3.23$  (CR71:  $Q_x=4.31, Q_y=4.88$ )
- Back up option:  $Q_x=4.41, Q_y=3.44$
- Momentum compaction:  $\alpha=0.04272$  (CR71: 0.069)
- Global slip factor:  $\eta=\alpha - \gamma^{-2} = -0.014$  (CR71:  $\eta=0.012$ )
- Local slip factor:  $\eta_{pk}=0!$
- Phase advances:  $Q_{x\_pk}=1.76, Q_{y\_pk}=1.25$
- Q8 – Q10 quads permuted with nearby sextupoles to minimize beam sizes in dipoles

# CR lattice (rib mode)

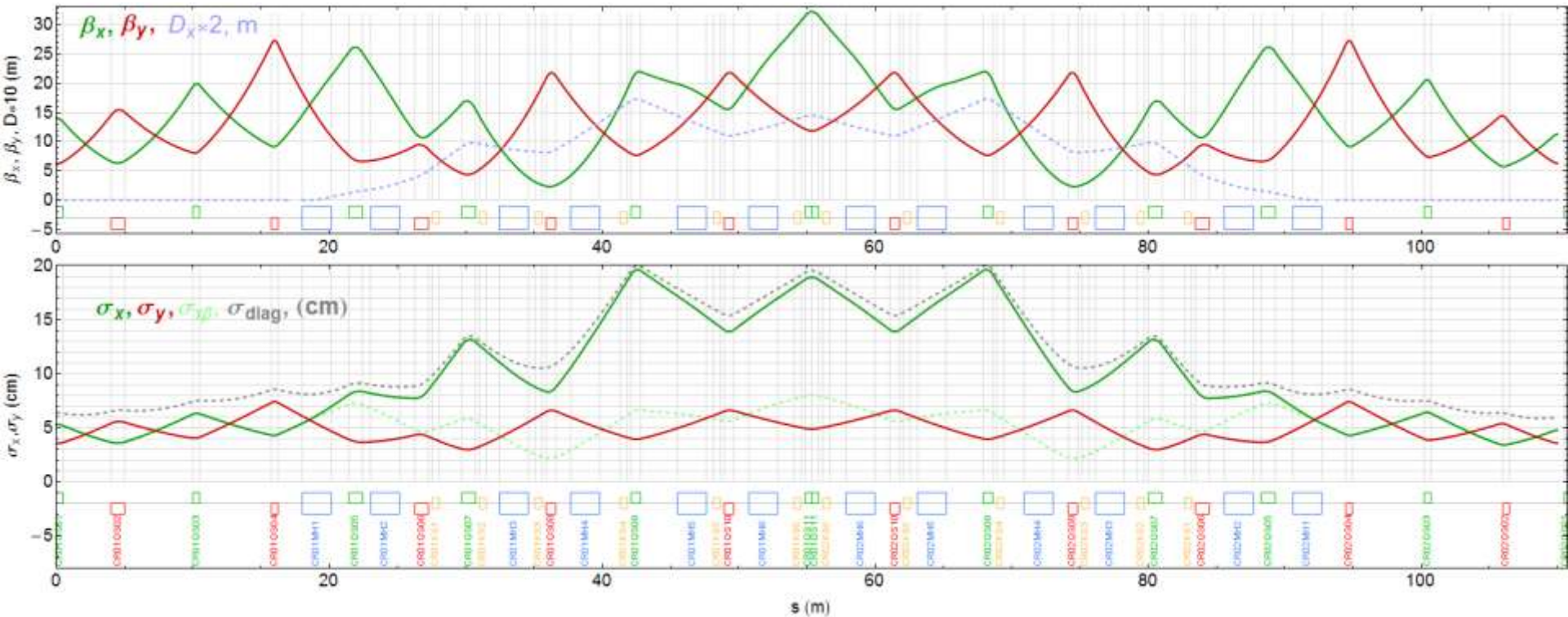



# CR Dipole magnet

## Requirements:

- 1.6 T maximum flux density
- Integral field non-uniformity –  $\Delta \int B \, dl / \int B \, dl = 1 \cdot 10^{-4}$
- Local field non-uniformity –  $\Delta B/B = 1 \cdot 10^{-3}$
- Lamination thickness <2mm
- Magnet to magnet identity =  $5 \cdot 10^{-4}$

## Decision:

- E-type magnet
- RaceTrack Coils
- Straight
  - Geometry parameters
  - Packing factor
  - Yoke and coils manufacturing cost
- Punched lamination from M1200-100A
- Lamination thickness 1mm – possible punching with acceptable tolerances and packing factor about 98%

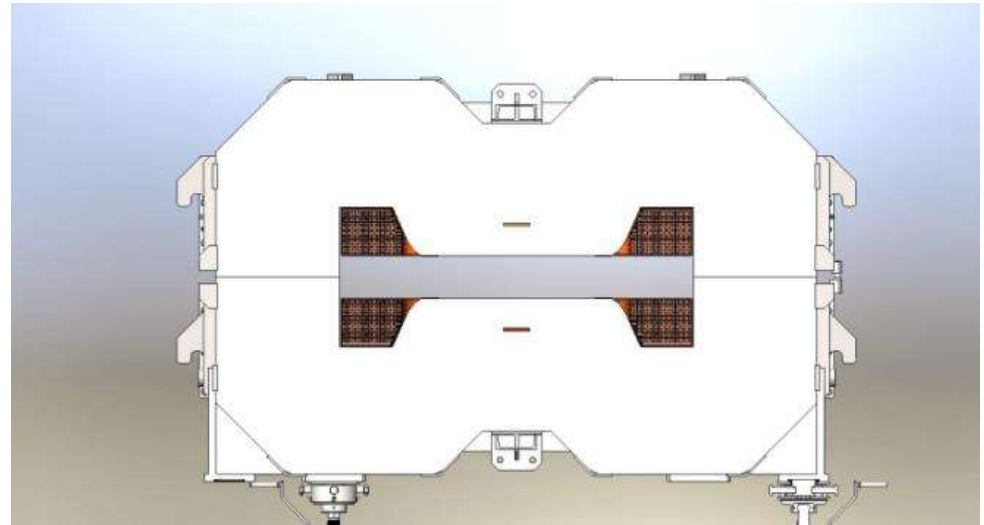

# CR Dipole Magnet pole type

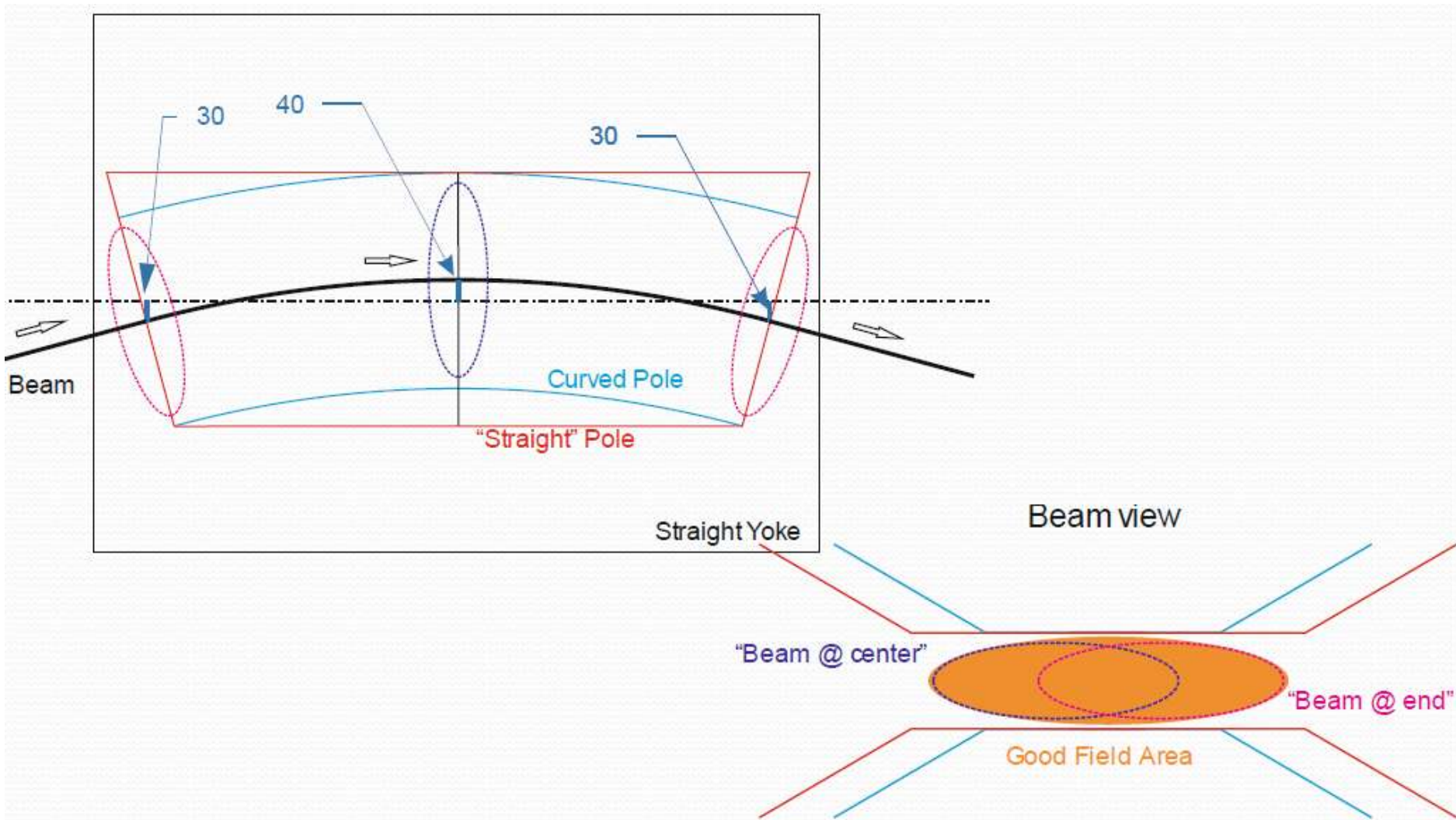

# Yoke and coil optimization

## yoke and coils

### Cutting non-saturated areas:

- helps reducing magnet mass without affecting field quality and magnitude
- is regular practice

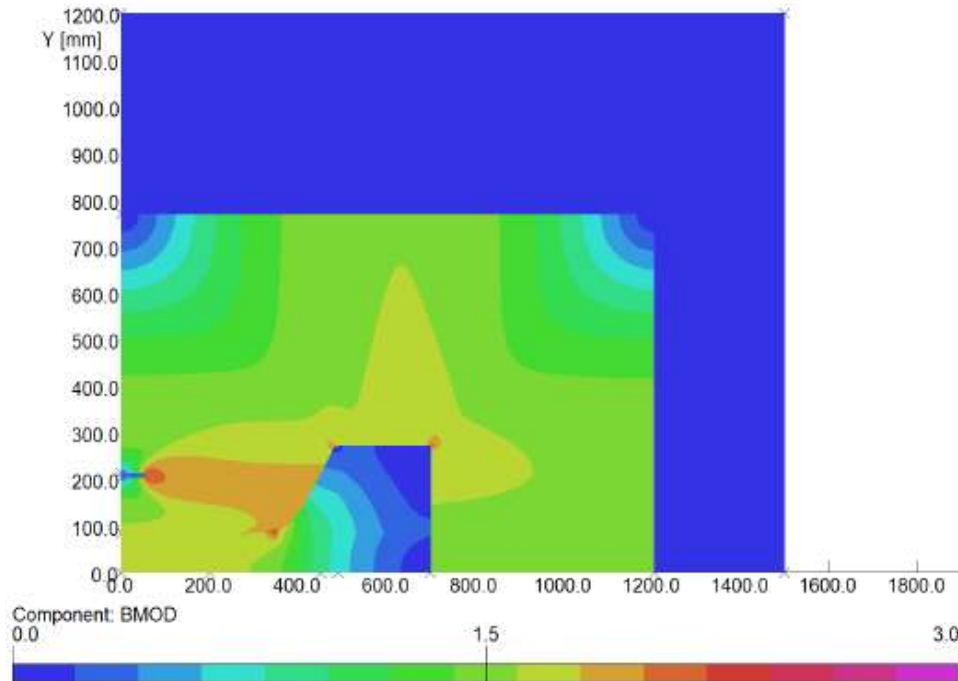

### Closing coils:

- Enlarges flux density in the pole

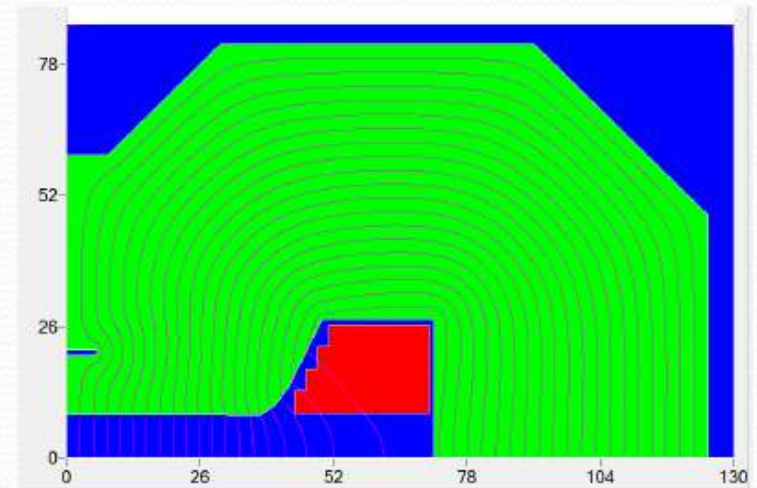

# CR Dipole

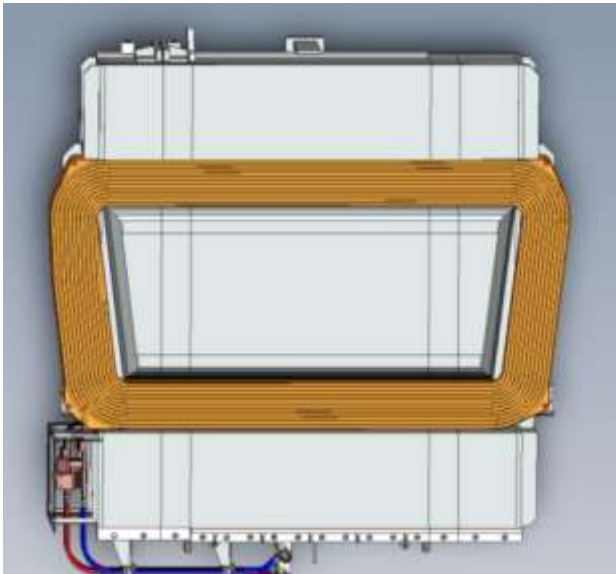
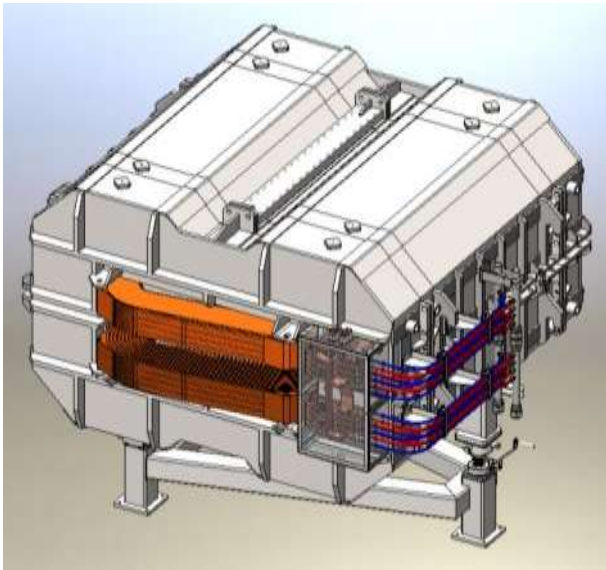

Parameter	Units	Value
Bending angle	degree	15
Flux density within gap	T	<b>1.5966</b>
Packing factor		0.98
BH-curve		M1200-100A
Air gap height	mm	170
Homogeneity area	mm <sup>2</sup>	386x102 and 262x128
Effective magnet length	mm	2119
Yoke length	mm	2121
Total length with coils	mm	2663
Iron weight	to	<b>51</b>
Coil width	mm	243
Coil height	mm	188
Turns		11x4+10x2+9x2=82
Conductor insulation	mm	0.5
Ground insulation	mm	2
Conductor cross section	mm <sup>2</sup>	20.1x20.1
Cooling channel diameter	mm	11
Fill factor		0.61
Copper weight	kg	3000
Current	A	1396
Average current density	A/ mm <sup>2</sup>	2.6
Current density in conductor	A/ mm <sup>2</sup>	4.6
Voltage	V	90
Power	kW	129
Temperature drop	°C	16
Water consumption	l/s	1.96
Water pressure	at	10
Mass of 1mm plate	kg	11.639

# Field inhomogeneity

At the center:

B=1.6 T

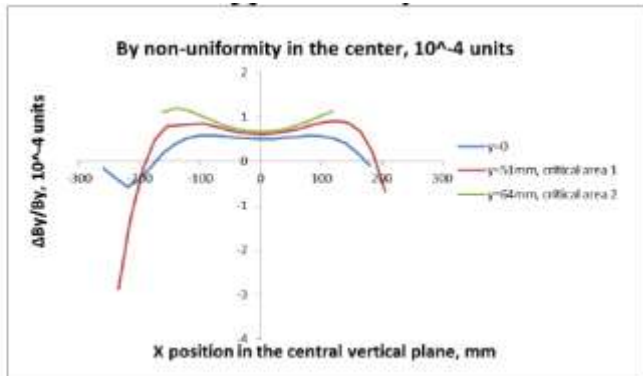

B=0.84 T

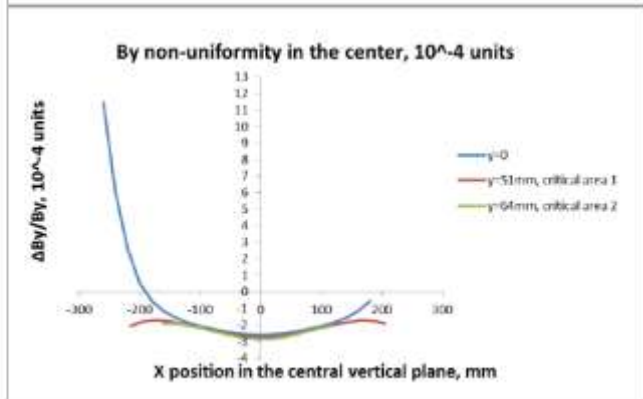

Integral:

B=1.6 T

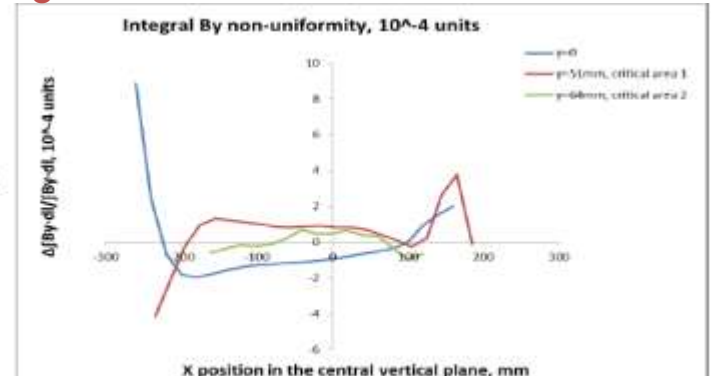

B=0.84 T

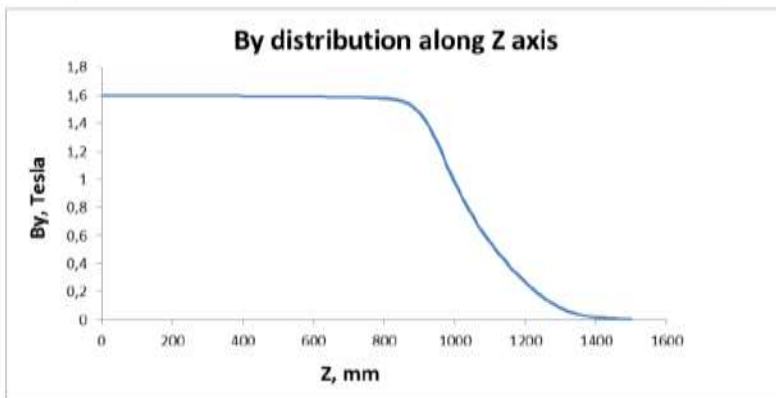
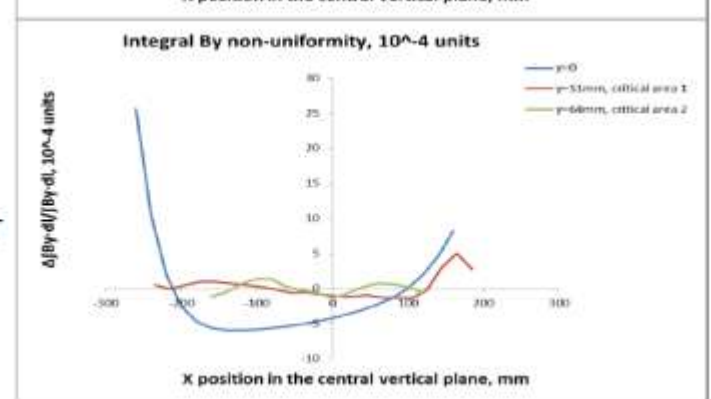

Several additional steps of calculations are required.

# CR Quadrupole Magnets

Three Wide Quads types to fulfill all the optics requirements:

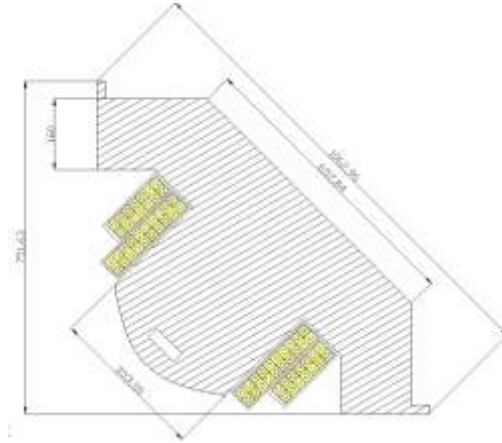
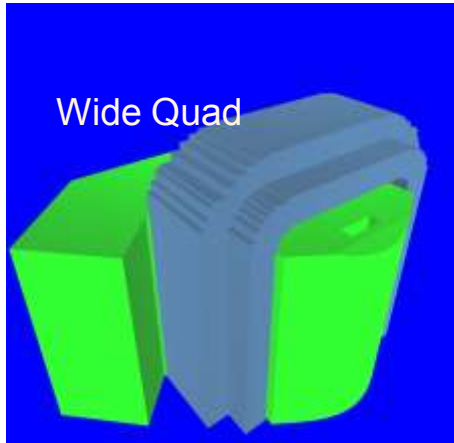

Parameter	Value	Units
Minimum quadrupole gradient	0.15	Tl/m
Maximum quadrupole gradient	4.9	Tl/m
Useable aperture	400x180/510x180	Mm <sup>2</sup>
Field quality $\Delta B/B$	$5 \cdot 10^{-4}$	
Inscribed circle radius	156	mm
Magnetic length	1000/700	mm
Maximal current of power supply	1530	A
Number	29	

and one Narrow Quad:

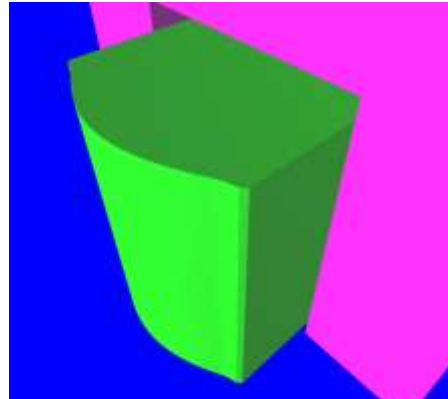
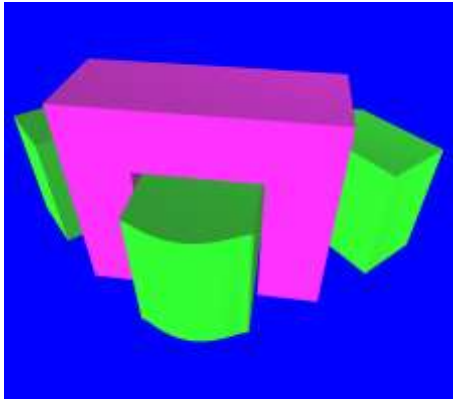

Parameter	Value	Units
Minimum quadrupole gradient	0.8	Tl/m
Maximum quadrupole gradient	9.0	Tl/m
Useable aperture	180x180	mm
Field quality $\Delta B/B$	$5 \cdot 10^{-4}$	
Inscribed circle radius	95	mm
Magnetic length	500	mm
Maximal current of power supply	1500	A
Number	11	

Narrow Quad

Preliminary design

# CR Sextupole Magnet

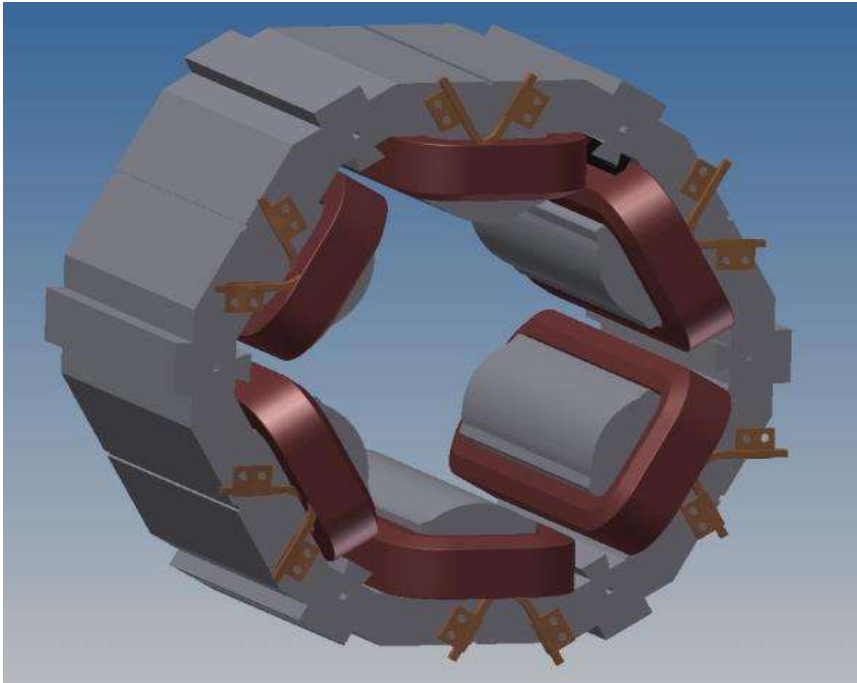

Parameter	Value	Units
Maximum sextupole strength	12	Tl/m <sup>2</sup>
Packing factor	0.98	
BH-curve	M1200-100A	
Usable aperture	Super elliptic with a=210mm b=10mm n=2.5	mm <sup>2</sup>
Iron length	500	mm
Number	24	

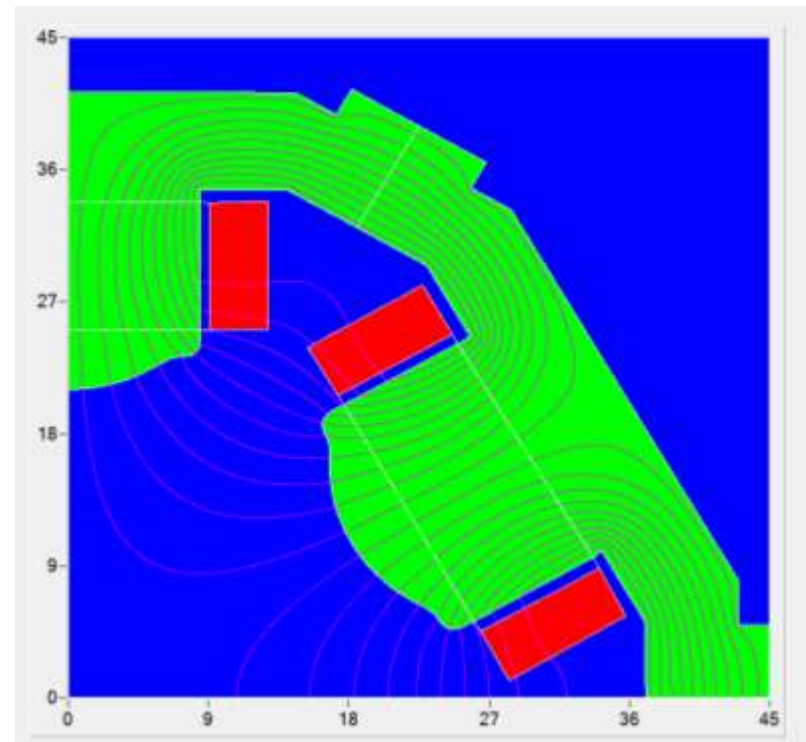

Preliminary design

# CR Dipole Vacuum Chamber

Super-elliptical shape and ribs:

Shape for  $a=195$  &  $b=73$  mm for deferent "S".

At  $S=3.5$  the shape well fits requirements for aperture.

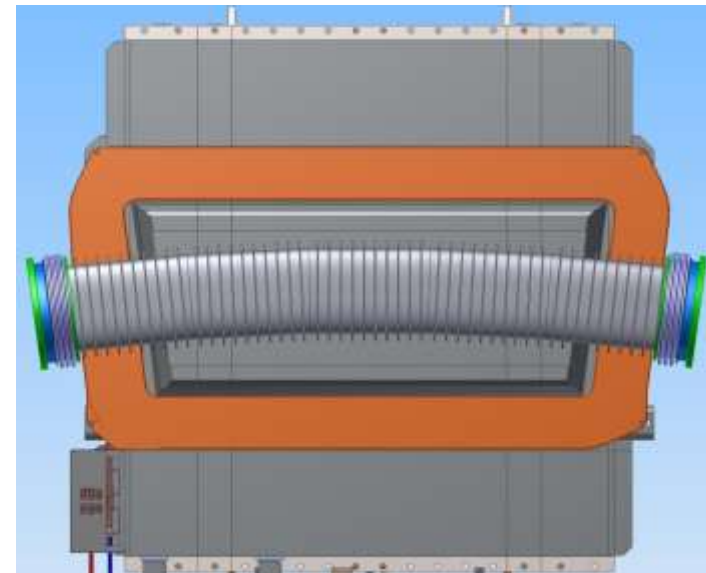
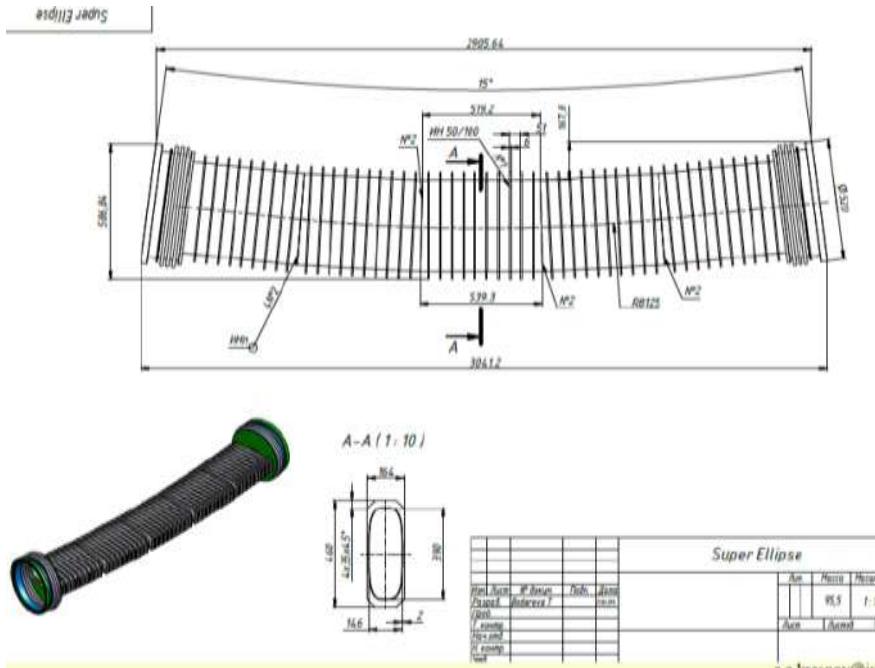
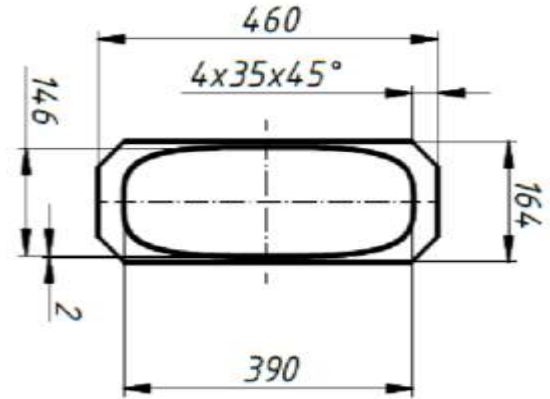
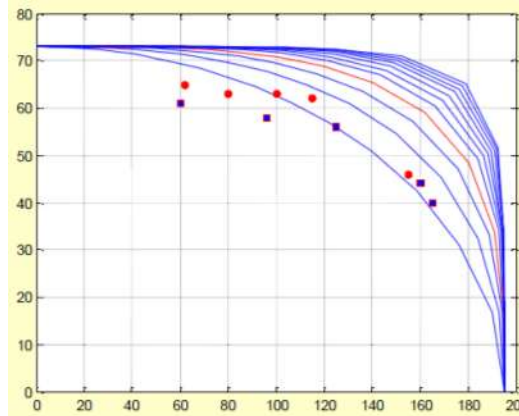

The space between the ribs can be used for baking elements.



# Injection. Septum.

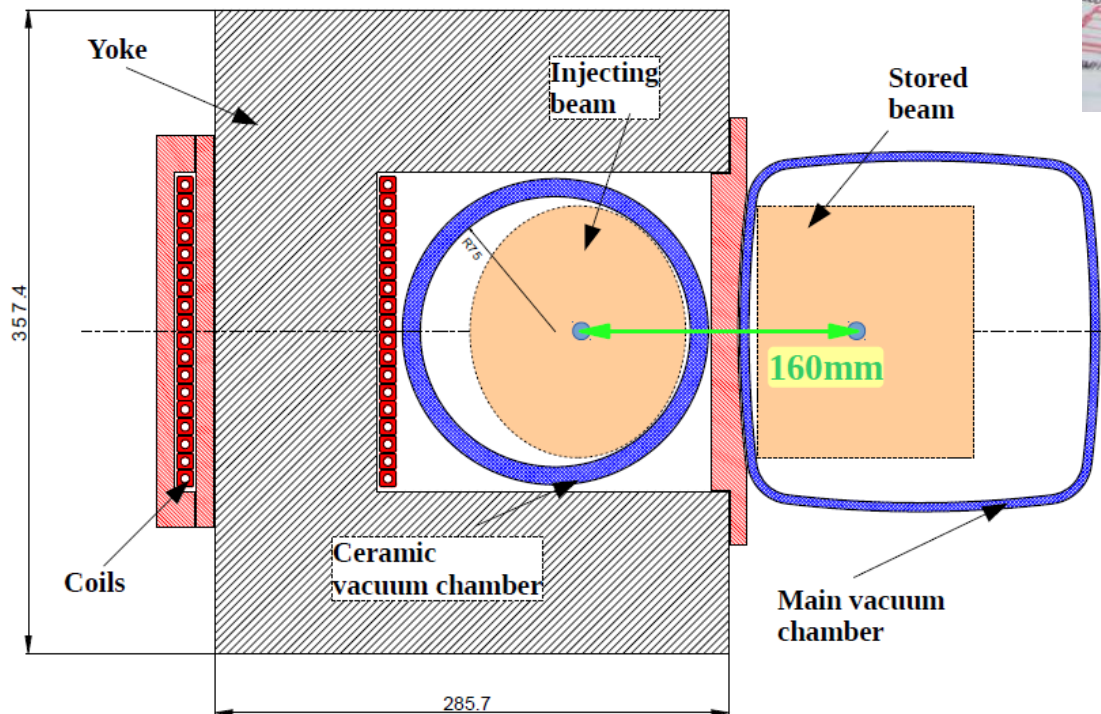
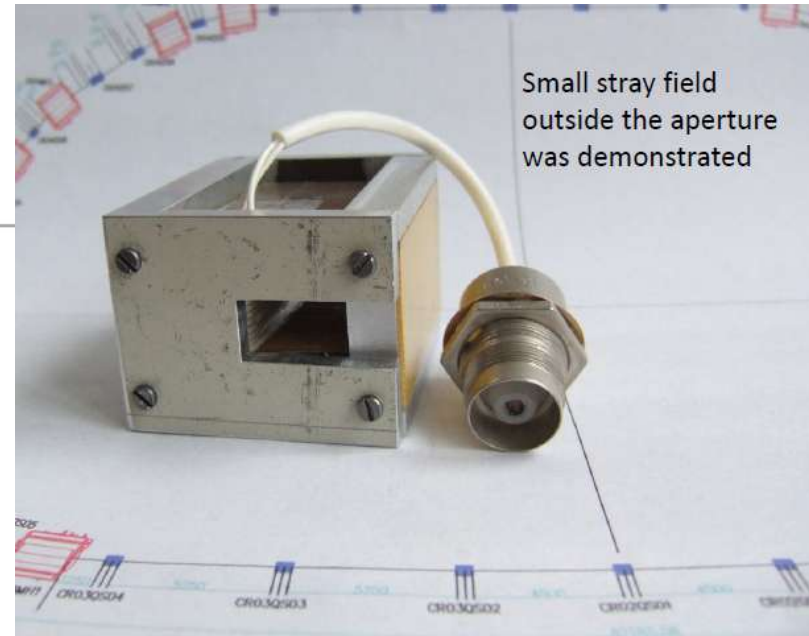
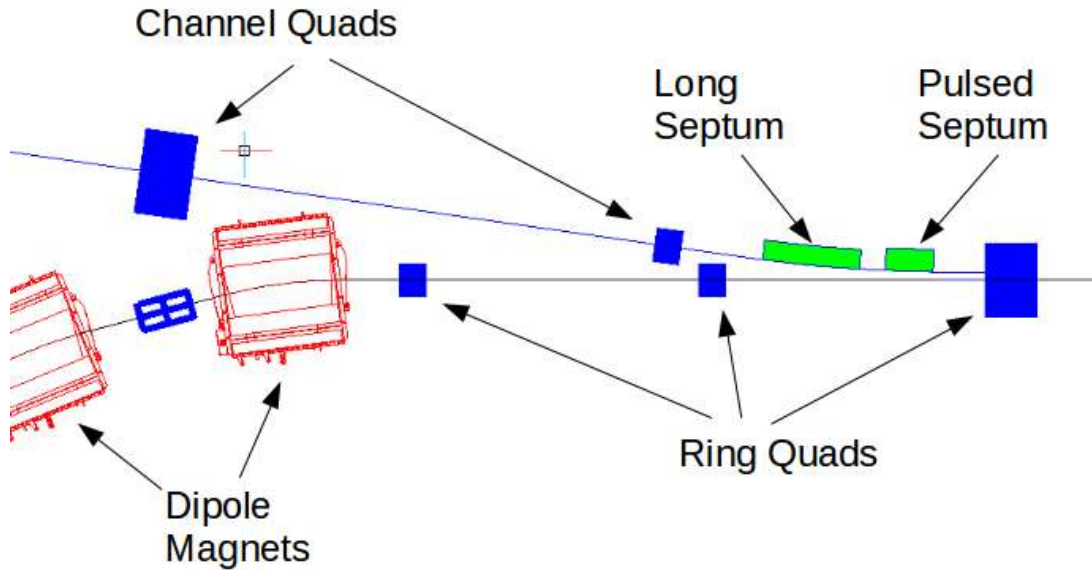

# Possible upgrade of RF bunch rotation

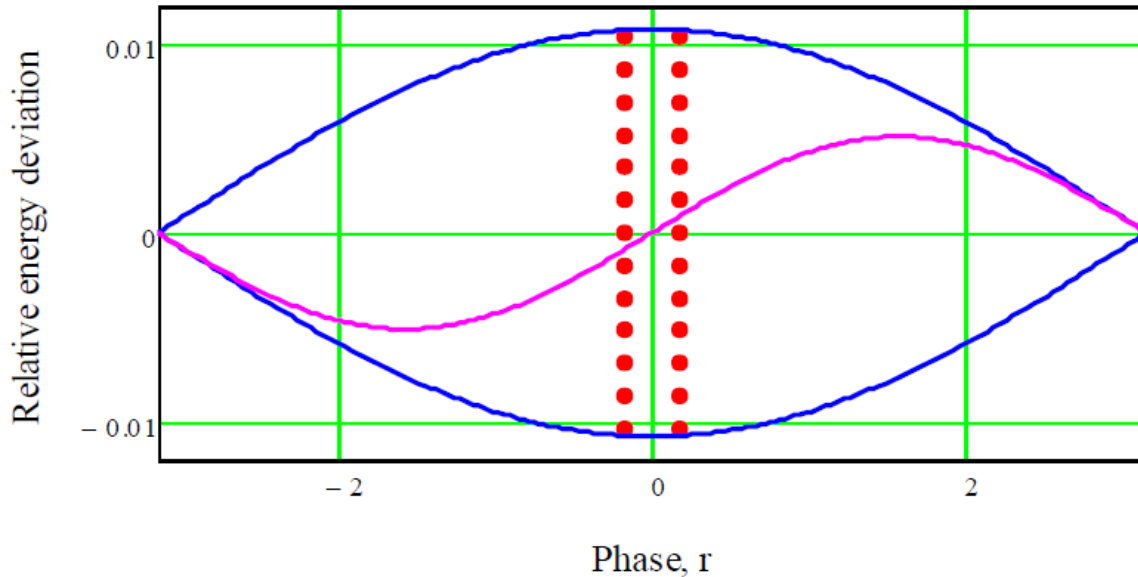

Rib:  
 $\eta_{rib} = -0.2$   
 $U1 = 200 \text{ kV}$

Pbar:  
 $\eta_{pbar} = -0.014$   
 $U1 = 100 \text{ kV}$

$\tau = 25 \text{ ns } (\pm 0.176 \text{ rad})$

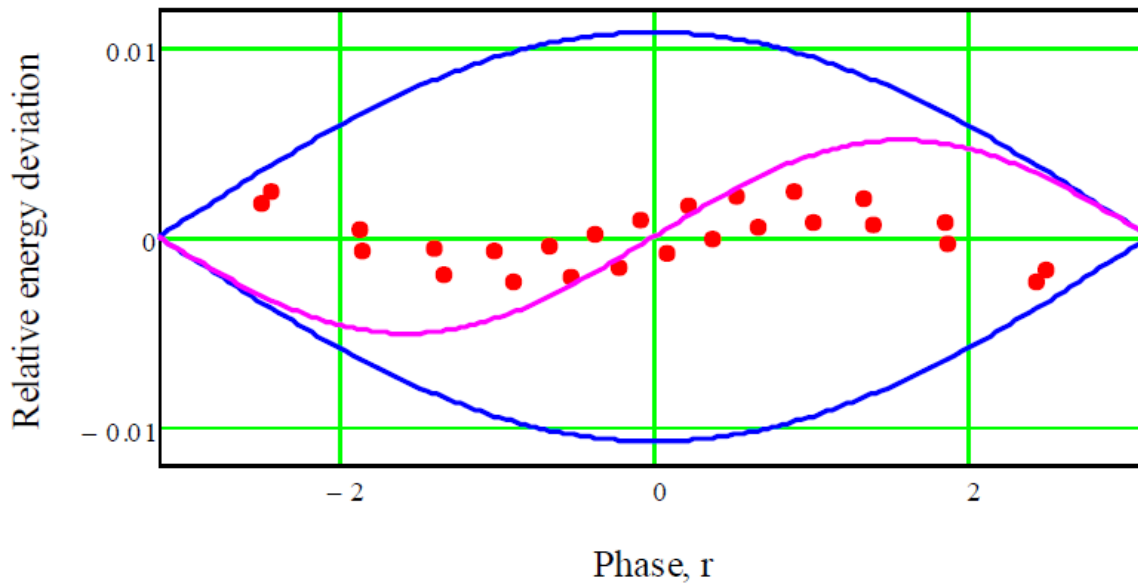

Single harmonic  
 $\Delta = \pm 0.239\% (\Delta p/p = \pm 0.35\%)$

# Possible upgrade of RF bunch rotation

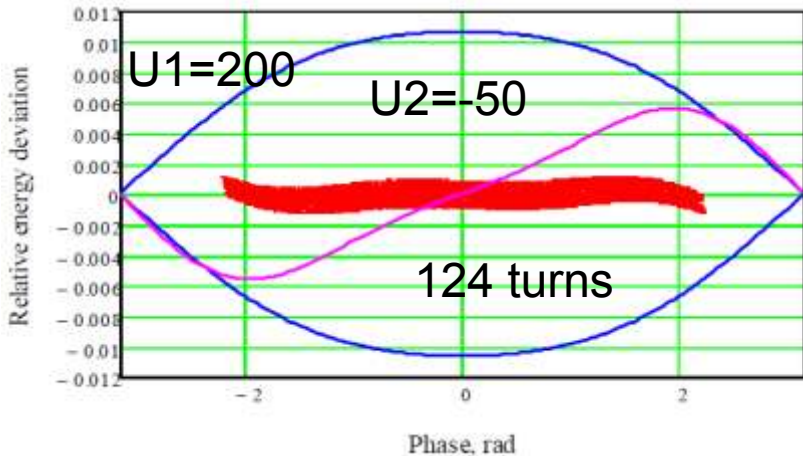
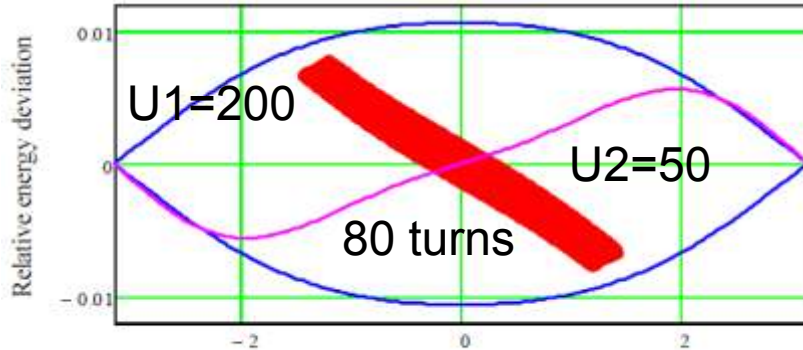
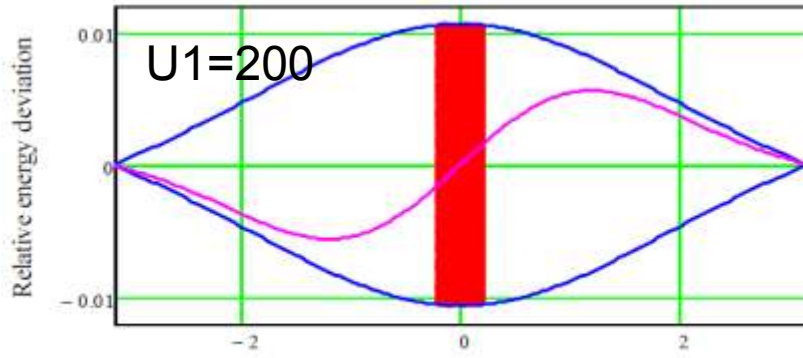

$\Delta = \pm 0.239\%$  ( $\Delta p/p = \pm 0.35\%$ )

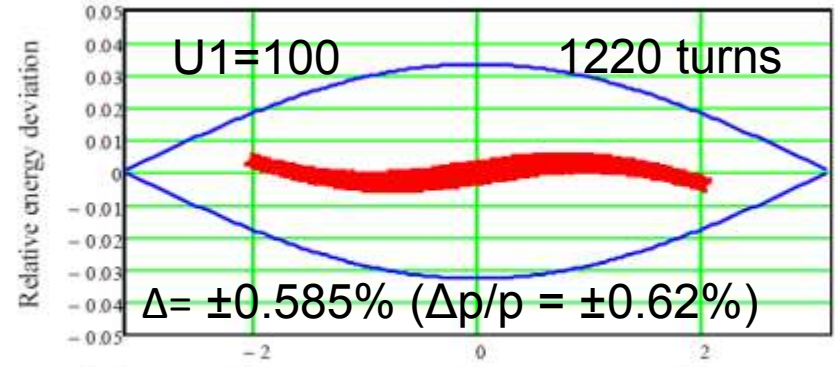

$\Delta = \pm 0.585\%$  ( $\Delta p/p = \pm 0.62\%$ )

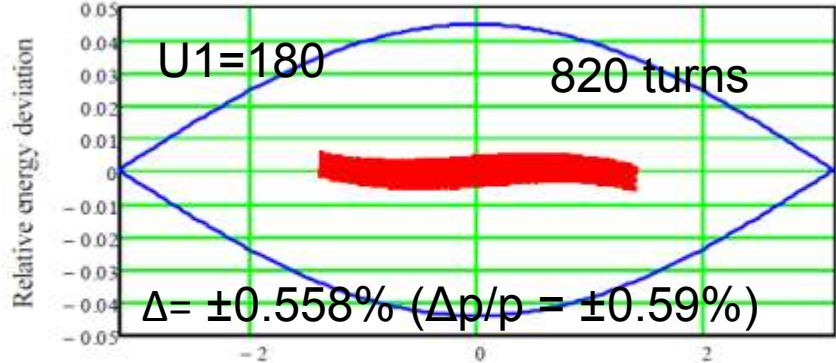

$\Delta = \pm 0.558\%$  ( $\Delta p/p = \pm 0.59\%$ )

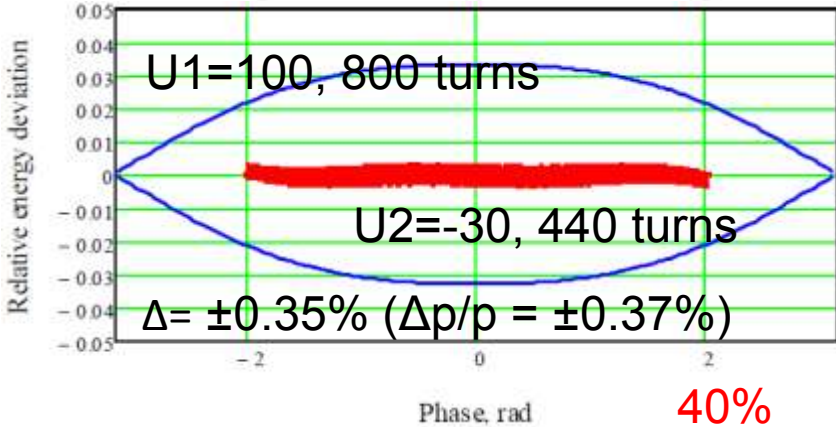

$\Delta = \pm 0.35\%$  ( $\Delta p/p = \pm 0.37\%$ )

40%

1 harm + 2 harm (180 grad) – not bad

# Conclusion

Collector Ring at FAIR project is under development now with the International Collaboration of scientists, designers and engineers.

Collector Ring project has flexible optics. Three different lattice modes will be used. Parameters of each mode are optimized for the CR tasks (mainly for stochastic cooling requirements) but still variable.

For high but reasonable field quality of main magnetic elements the nonlinear dynamics affects on the antiproton injection efficiency very weakly. Estimated antiproton beam losses do not exceed 5%.

At the same time simulated DA usually turns out to be optimistic comparatively to one of the real machine. The accurate tune scan should be done for DA optimization in both pbar and RIB lattice modes

The Work strongly in progress...

**Thank you for your attention!**



**Yu.Rogovsky on behalf of BINP and GSI team for FAIR, 10.10.2014**

- В конце лета был согласован и подписан коллаборационный контракт между ИЯФ и ФАИР
- С этого момента ответственность за проект строительство СиаР лежит на ИЯФ.
- Это очень важный шаг в создании междугосударственной коллаборации целью которой является строительство и ввод в эксплуатацию нового ускорительного комплекса мирового масштаба для исследования антипротонов и тяжелых ионов в Дармштадте, Германия