

# MEASUREMENT OF THE DOSE RATE AND THE RADIATION SPECTRUM OF THE INTERACTION OF 2 MeV PROTON BEAM WITH A VARIETY OF STRUCTURAL MATERIALS\*

D. Kasatov<sup>#</sup>, A. Makarov, S. Taskaev, I. Schudlo  
BINP SB RAS, Novosibirsk, Russia,

## Abstract

At the BINP, a pilot epithermal neutron source is now in use. It is based on a compact Vacuum Insulation Tandem Accelerator (VITA) and uses neutron generation from the reaction  ${}^7\text{Li}(p,n){}^7\text{Be}$ . Irradiation experiments using various structural materials were carried out. The results of measuring the intensity and the spectra of the  $\gamma$  and X-ray radiation are discussed in the present work. This work is a part of a plan to create a therapeutic beam and strategies for the use of the accelerator for clinical application.

## INTRODUCTION

Presently, Boron Neutron Capture Therapy (BNCT) [1] is considered to be a promising method for the selective treatment of malignant tumors. The results of clinical tests, which were carried out using nuclear reactors as neutron sources, showed the possibility of treating brain glioblastoma and metastasizing melanoma not curable by other methods [2, 3]. The broad implementation of the BNCT in clinics requires compact inexpensive sources of epithermal neutrons. At the BINP the source of epithermal neutrons based on 2 MeV Vacuum Insulation Tandem Accelerator (VITA) and neutron generation through  ${}^7\text{Li}(p,n){}^7\text{Be}$  reaction was proposed [4] and created.

General view of the accelerator is shown in Fig. 1. Negative hydrogen ions are injected and accelerated up to 1 MeV by potential applied to the electrodes, then  $\text{H}^-$  turn into protons in the stripping target and at last the protons are accelerated up to 2 MeV by the same potential. Pumping of the gaseous stripping target is carried out by cryogenic and turbomolecular pumps through the jalousies. The potential of the high-voltage and five intermediate electrodes is supplied by a high-voltage source through the insulator which has a resistive divider.

Presented work is aimed on measurement of lithium target radiation hazard and to find materials for high-energy beam transporting channel and for substrate of neutron producing target with minimum radiation emission during proton bombardment. There were studied different materials.

## EXPERIMENTAL LAYOUT

Generation of  $\gamma$ - rays was carried out by directing the proton beam on targets made of various materials. The

\* The study was performed by a grant from the Russian Science Foundation (Project No.14-32-00006) with support from the Budker Institute of Nuclear Physics.

<sup>#</sup> kasatovd@gmail.com

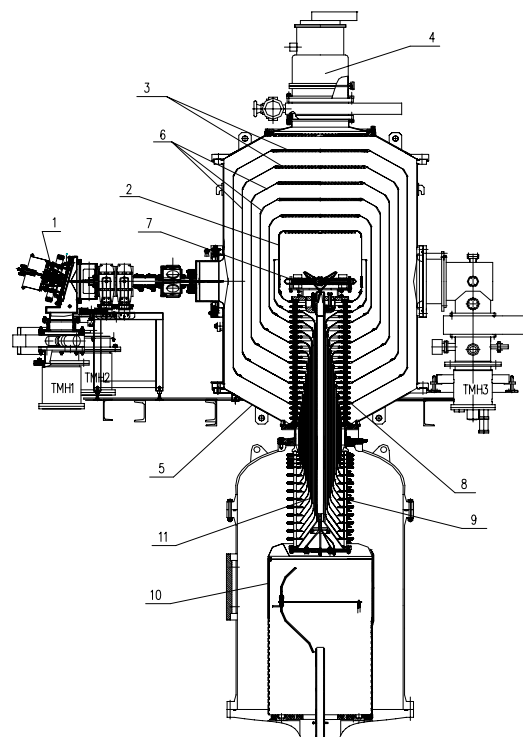

Figure 1: High-current vacuum insulation tandem accelerator: 1 – ion source ( $\text{H}^-$ ); 2 – high voltage electrode; 3 – electrode shutters; 4 – cryo pump; 5 – accelerator vacuum volume; 6 – intermediate electrodes; 7 – stripping target; 8 – feedthrough insulator (vacuum part); 9 – feedthrough insulator (gas part); 10 – high voltage source; 11 – coaxial feeding tubes.

target is a disc of 100 mm diameter and thickness from 1 mm to 10 mm depending on the material mounted on a cooled copper substrate. Gamma spectra were detected by BGO spectrometer. BGO spectrometer was located at a distance of 75 cm from the target along the beam axis and was covered by a lead shielding having thickness of 50 mm with collimation hole 25 mm in diameter. The spectrometer was calibrated using the isotopes  ${}^{137}\text{Cs}$  and  ${}^{60}\text{Co}$  taking into account the background radiation from the accelerator [5]. After irradiation the target was extracted and induced radioactivity was measured. For this purpose we used NaI and BGO detectors.

Dose rate measurements were carried out by an automatic system based on ionization chambers. In some cases the neutron yield was registered by the lithium glass detector.

## EXPERIMENTAL RESULTS

### Gamma-ray Generation

Various materials (Li, C, Al, Si, Ti, V, Fe, Cu, Mo, Ta) were bombarded by 2 MeV protons. The average proton current was 400 mA. Gamma spectra normalized to the current and time are shown in Fig. 2.

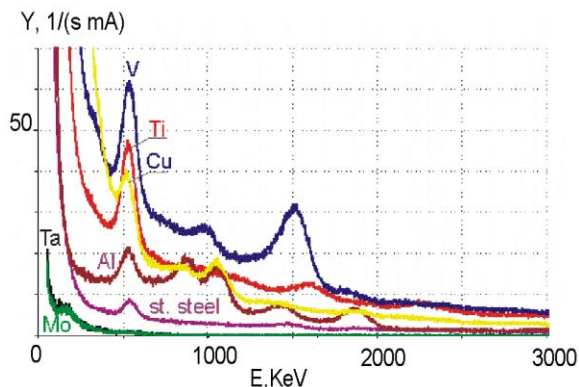

Figure 2: Gamma spectra of different materials under proton beam.

Titanium and graphite showed significant activation by the proton beam (Fig.2 and Fig.3). In other cases activation dropped fast before the target was retrieved. Target retrieving time was about 15 minutes.

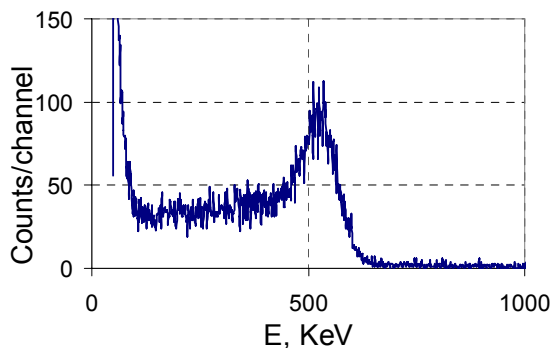

Figure 3: Gamma spectrum of  $^{12}\text{C}(p)^{13}\text{N} \rightarrow \beta^+(10 \text{ min}) \rightarrow ^{13}\text{C}$  (dose rate  $0.5 \mu\text{Sv/h}$ ).

Also irradiation experiments were carried out using a proton beam deposited on lithium fluoride and barium fluoride as an attempt of generating positrons in reaction  $^{19}\text{F}(p, \alpha^+ e^-)^{16}\text{O}$ . Spectra are shown in Fig. 5. In case of lithium fluoride the positron line is superimposed with 478 KeV line which is produced in  $^7\text{Li}(p, n)^7\text{Be}$  reaction.

### Neutron Generation

At energy of 2 MeV protons on some materials (Ti, V,  $\text{LiF}_2$  and stainless steel) experienced significant neutron flux. For them, the neutron yield was measured at a lower energy proton beam.

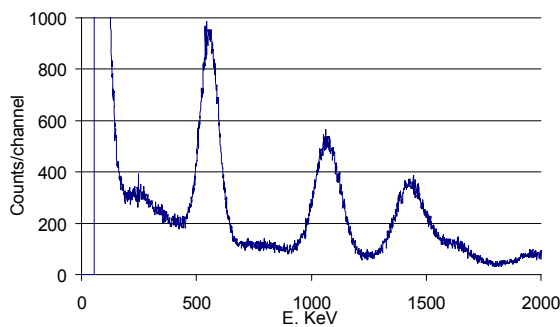

Figure 4: Gamma spectrum of activated natural titanium 3 days after irradiation (dose rate  $4.6 \mu\text{Sv/h}$ ).

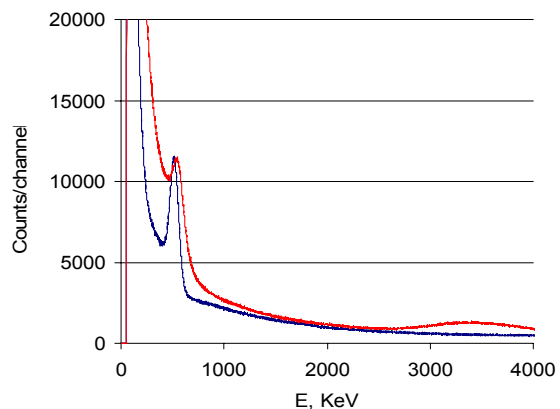

Figure 5: Gamma spectra of lithium fluoride (red) and barium fluoride (blue).

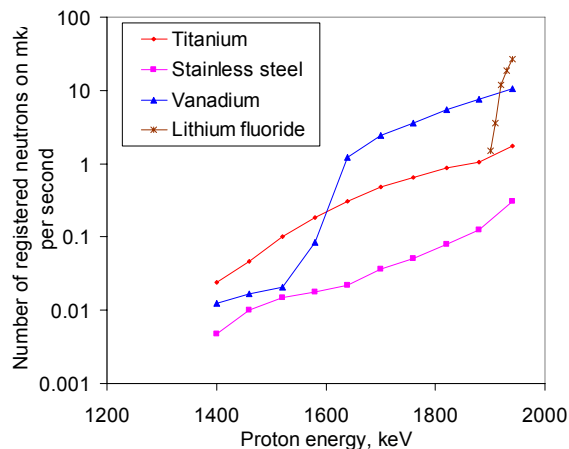

Figure 6: Neutron yield for different materials.

## SUMMARY

Bombardment of C, Al, Si, Ti, V, Cu and stainless steel by 2 MeV protons leads to intense  $\gamma$ -ray emission. Bombardment of stainless steel, titanium, vanadium and lithium fluoride by 2 MeV protons leads also to neutron generation. Therefore the best materials for minimizing of gamma-rays radiation under 2 MeV protons are tantalum and molybdenum.

**REFERENCES**

- [1] G. Locher, Am. J. Roentgenol. Radium Ther. 36 (1936) 1.
- [2] H. Hatanaka, Basic Life Sci. 54 (1990) 15.
- [3] H. Hatanaka, and Y. Nakagawa, Int. J. Radiat. Oncol. Biol. Phys. 28 (1994) 1061.
- [4] B. Bayanov, et al., NIM A 413 (1998) 397.
- [5] I. Sorokin, et. al., “X-ray Radiation of the High-Voltage Elements of the Tandem-Accelerator with Vacuum Insulation”, MOPPA030, these proceedings.