

USE OF FAST MAGNETIC BEAM RASTER SYSTEM FOR INR ISOTOPE PRODUCTION FACILITY

O.Volodkevich, S.Bragin, A.Feschenko, O.Grekhov, Yu.Kiselev, V.Kokhanyuk, V.Mikhailov, A.Mirzojan, V.Serov, Institute for Nuclear Research of RAS, Moscow, Russia

Abstract

Fast magnetic beam raster system for INR isotope production facility is developed and implemented. The system enables to increase the isotope production efficiency by providing a possibility of using a higher intensity proton beam on the target of the isotope production facility. First experimental results of system application for irradiation of the targets are presented.

INTRODUCTION

Interaction of the pulsed proton beam with the irradiated target results in fast (during the beam pulse) local heating of the target material. So the target material density is decreased, consequently, the efficiency of beam interaction with the target is decreased too. This effect causes limitation of beam intensity on the target and restricts the possibilities of isotope production. The problem can be solved by reducing the beam density on the target. But one cannot just increase the cross section of the beam for the existing configuration of the irradiation facility and beam extraction line. Increasing of beam cross section is provided by fast circular or elliptical scan of the beam on the target. Thus, the heating of target material is reduced, consequently, the beam intensity and irradiation efficiency can be increased. Fast beam scanning on the target is done by the Beam Fast Scan System (BFSS), which has been developed [1] and installed upstream the target. Target irradiation is carried out at beam energies from 100 MeV up to 158.6 MeV.

THE STRUCTURE AND PARAMETERS OF THE SYSTEM

Beam scanning is performed by means of its deflection in two mutually perpendicular alternating magnetic fields having the same frequency and quarter period phase shift. Mutually perpendicular alternating magnetic fields are created by two windings. Each winding consists of two symmetrical coils connected in series. Winding X deflects the beam in the horizontal direction, winding Y deflects the beam in the vertical direction. Frequency of fast beam scanning is about 5 kHz. One scan cycle takes one beam pulse of 200 μ s. The angle of beam deflection in this system has been calculated according to the results of magnetic field calibration for windings X and Y. It equals to 1.5 mrad at nominal winding current and beam energy of 158 MeV. Corresponding deflection of the beam on the target is equal to 4.5 mm in both planes. This system gives the possibility to vary the beam size and the beam scan radius on the target in wide range. BFSS consists of electromagnetic windings and control system.

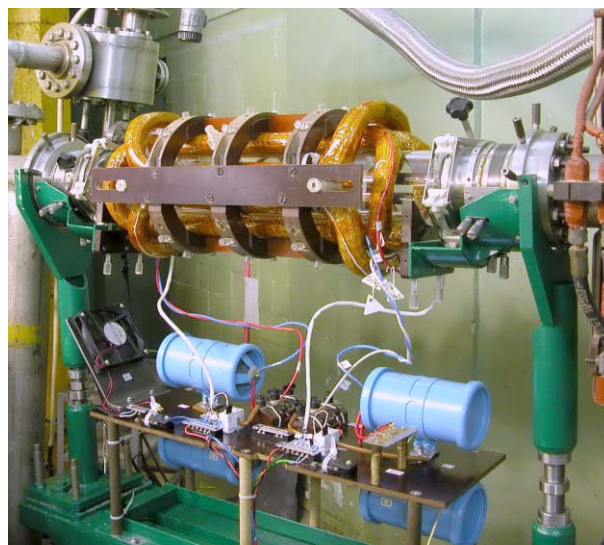

Figure 1: Windings assembly with the capacitor bank.

The windings are designed for vertical and horizontal deflection of the beam and are arranged one above the other on the outside of a glass chamber, which is a part of beam transportation line (Fig. 1). Each winding is included in parallel resonant circuit. The main characteristics of the system are given in Table 1.

Table 1: The main parameters of the system

Supply voltage	~220V, 50Hz
Power consumption	≤ 500 W
Resonant circuit X	
Amplitude of deflecting magnetic field	71.5 G
Amplitude of nominal current	4.4 A
Effective magnetic length of winding	40.7 cm
Number of turns of the winding	309
Inductance of the winding	36 mH
Resonant circuit Y	
Amplitude of deflecting magnetic field	55.7 G
Amplitude of nominal current	3.8 A
Effective magnetic length of winding	52.3 cm
Number of turns of the winding	282
Inductance of the winding	36 mH
Control	
Number of channels	2
Output signal shape	Sinusoidal
Range of frequency adjustment	4.6÷5.0 kHz
Maximum output current	10 A
Current adjustment range	0÷10 A
Phase adjustment range	±90°

The BFSS installation, tuning and testing were carried out in 2013.

Frequency tuning of BFSS resonant circuits was done by adjustment the position of the windings and by regulating procedure with ferrite rods.

The pressure of the residual gas in vacuum chamber can affect the operation of BFSS. Such influence has been observed during the tests. It is concerned with the ionization of residual gas in vacuum chamber and the occurrence of high-frequency discharge, which leads in turn to a change in the resonant frequencies of the circuits. This effect occurs at the pressure of the residual gas higher than 10^{-5} Torr and it was visually observed by the residual gas glow inside vacuum chamber (Fig. 2). Therefore, it is necessary to maintain a high vacuum in order to avoid the appearance of discharge.

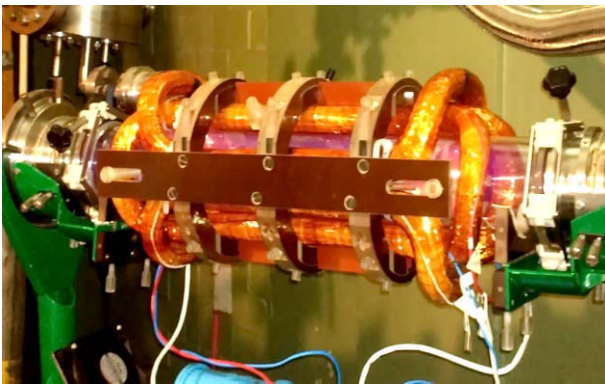

Figure 2: Residual gas glow at low vacuum.

The software for BFSS control has been created on the basis of LabView package. It is integrated into the control system of linear accelerator.

Operator can continuously monitor the BFSS operating mode. BFSS control interface, which provides the possibility to monitor and to control the parameters of the system is shown in Fig. 3.

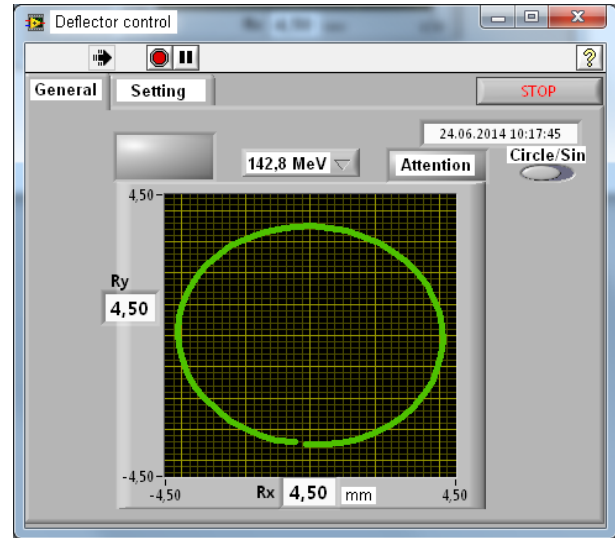

Figure 3: BFSS control interface.

BFSS winding current should provide a specified amplitude of the magnetic field and the value of beam deflection on the target. If the current drops below a predetermined threshold, the interlock system locks the beam passage through the accelerator. It is necessary to avoid the damage of the target at too high density of the beam.

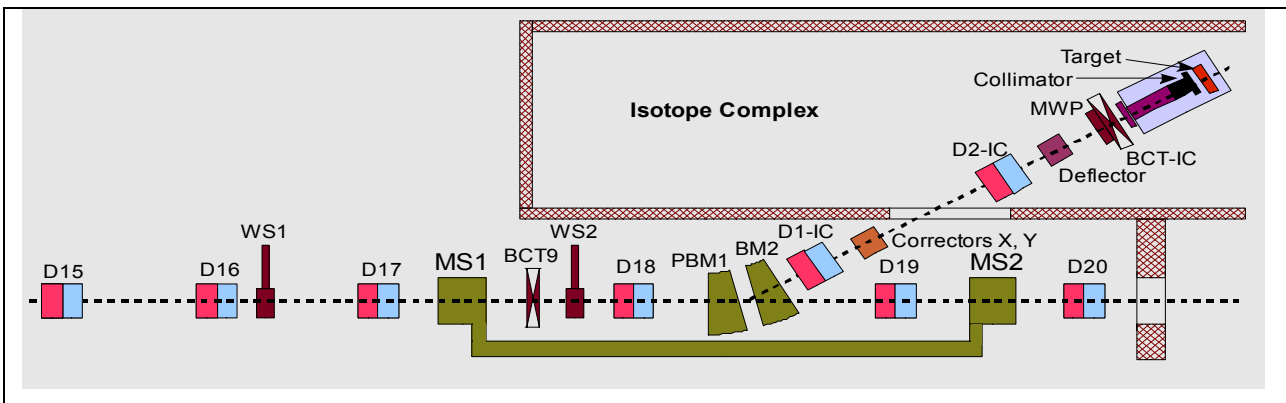

Figure 4: Layout of beam transportation channel in the area of beam extraction to isotope complex. D-quadropole doublets; PBM1, BM2-bending magnets; MS1, MS2-longitudinally matching sections; BCT-IC, BCT9-beam current transformers; WS1, WS2-wire scanners; MWP-multiwire profilometer.

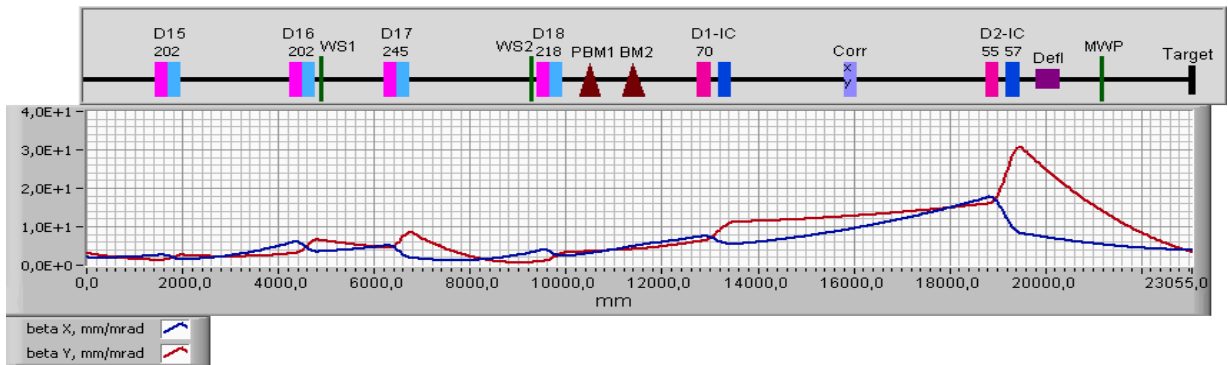

Figure 5: Lattice of beam extraction line and tracing of characteristic β -functions.

RESULTS

Study of BFSS operation with proton beam of INR linac was carried out in 2014. First experimental results were obtained.

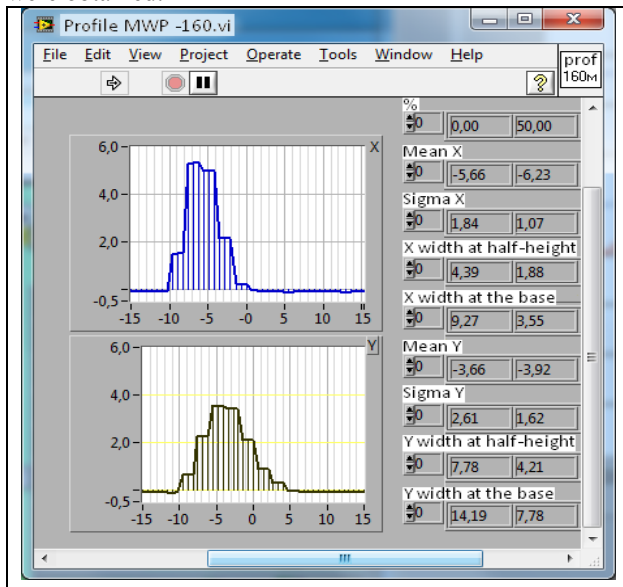

Figure 6: Characteristic beam profiles at MWP.

Table 2: Calculated and measured amplitudes of beam scanning along horizontal (R_x) and vertical axis (R_y)

Beam energy	143 MeV
Current in winding X	2.05 A
Current in winding Y	1.80 A
Calculated R_x on the target	± 2.2 mm
Calculated R_y on the target	± 2.2 mm
Measured R_x on the target	± 2.35 mm
Measured R_y on the target	± 2.2 mm

Equipment layout and behavior of characteristic β -functions (beam envelope is proportional to $\sqrt{\beta}$ in the area of beam extraction to isotope complex target [2] are shown in Fig. 4 and Fig. 5. Amplitudes of beam scanning on the target were calculated according to the results of magnetic field calibration for both windings. Experimental results of beam center deflection on the target were determined by beam center measurements at

MWP. MWP is located in the drift space between deflector and the target. Characteristic beam profiles are shown in Fig. 6.

Beam scanning amplitudes R_x , R_y measured at MWP location are $\pm 0,85$ mm and $\pm 0,80$ mm respectively. These results can be used for determination of beam center deflections on the target, since the beam deflection on the target is 2.75 times higher than its deflection at MWP location. Comparative results for calculation and measurement are shown in Table 2.

In isotope production session at INR linac five targets have been irradiated by 143 MeV proton beam in almost continuous operation mode. BFSS has been used as fast beam deflector. It successfully and smoothly worked during the entire sessions. Targets irradiation was carried out at following beam parameters: $\sigma_x \approx 2.6$ mm, $\sigma_y \approx 2.2$ mm – rms beam sizes on the target; $R_x \approx 2.6$ mm, $R_y \approx 3.6$ mm - amplitudes of beam scanning on the target.

CONCLUSION

The first experimental results of using the BFSS system for INR isotope production facility confirmed the possibility to change the sizes of the beam and the amplitudes of beam scanning on a target within a wide range. BFSS has proven its reliability and flexibility. BFSS will be further used in isotope production sessions at INR linac.

REFERENCES

- [1] O.Grekhov, I.Zhelezov, V.Mikhailov, V.Serov, A.Feschenko. "Development of Fast Magnetic Beam Raster System for INR Isotope Production Facility", Problems of Atomic Science and Technology, Series «Nuclear Physics Investigations», 2013, № 6 (88), p. 86-89.
- [2] S.Bragin, A.Feschenko, O.Grekhov, Yu.Kiselev, A.Mirzozan, V.Moiseev, I.Vasilyev, O.Volodkevich., "Proton Beam Monitoring and Forming on the Target of Isotope Complex at INR Linac.", Problems of Atomic Science and Technology, Series «Nuclear Physics Investigations», 2010, № 2 (66), p. 96-100