

HIGH PRECISION POWER SUPPLY FOR ACCELERATOR MAGNETS

Ajoy Sankar Banerjee, Variable Energy Cyclotron Centre, Kolkata 700064, India

Abstract

High precision power supplies used in accelerator systems have stability of the order of 5ppm to 100ppm depending on the functional requirement of the magnet to be excited. The paper highlights the various design considerations, aspects and important features for obtaining high current stability of such high precision power supplies.

INTRODUCTION

The stability of the high precision power supplies used in an accelerator system is an important factor for obtaining highly stable beam output required for various experimental studies. Line, load and temperature variations are the three important factors against which these power supplies have to combat to maintain high stability.

MAIN FEATURE OF THE POWER SUPPLY

Stability is the main important feature of these power supplies which lies between $\pm 5\text{ppm}$ to $\pm 100\text{ppm}$ i.e. the output current will have to remain in the error band of $\pm 5\text{ppm}$ to $\pm 100\text{ppm}$ under various environmental perturbations such as

1. The input AC lines may ramp or step by $\pm 10\%$
2. The magnet resistance may vary by 20%.
3. The ambient temperature could change from 15°C to 45°C .
4. There are AC line harmonics and notches generated by other power supplies.
5. The power supplies themselves generate a fundamental 600Hz rectifier ripple and some harmonics of 50Hz due to line imbalances.
6. There are R.F. interferences.

The table 1 shows stability requirement of high precision power supplies used for VECC room temperature accelerator system.

Table 1. Stability Table

High precision Power Supply	Stability
Main Magnet P.S. 3000A/150V Analyzing Magnet P.S. 500A/150V	5 ppm.
Trim coil P.S. 2500A/30V, 300A/25V Switching magnet P.S. 300A/150V	10 ppm.
Quadrupole magnet P.S. 300A/30V Steering magnet P.S. 10A/100V Valley coil P.S. 300A/30V	100 ppm.

ACTION TO ACHIEVE HIGH STABILITY

- Proper selection of rectifier circuit configuration for high ripple frequency to reduce ripple voltage

- Using both passive and active filter circuit for fine reduction of ripple voltage
- Adoption of proper regulating loops for good voltage and load regulation
- Using DCCT, working on zero flux principle, for sensing load current with 0.001% accuracy for high current regulation and stability
- Proper thermal management to control temperature of the heat dissipating devices and critical components of the power supply to minimize drift in characteristics
- Attenuation of R.F. pick-up and noise
- Taking proper action to reduce line disturbances

BLOCK DIAGRAM OF A HIGH PRECISION POWER SUPPLY

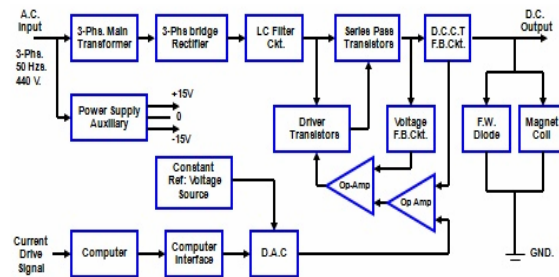

Figure 1: Block diagram of power supply

Series pass transistor controlled linear mode circuit configuration is generally adopted for simplicity in design and control.

Rectifier Circuit

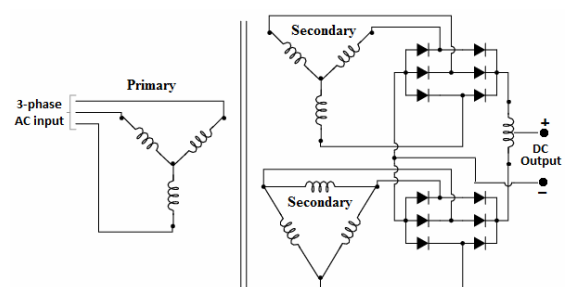

Figure 2: Rectifier circuit

Considering the optimum rectification condition twelve pulse bridge rectifier circuit as shown in the Fig.2 is adopted. This connection provides a low ripple voltage of 1.02%

LC Filter Circuit

The LC filter has almost constant ripple characteristics at all load currents above I_b where the diode conduction angle reaches 180° and the current becomes continuous.

Because of the good voltage regulation at current above I_b , a bleeder resistor across the output is used.

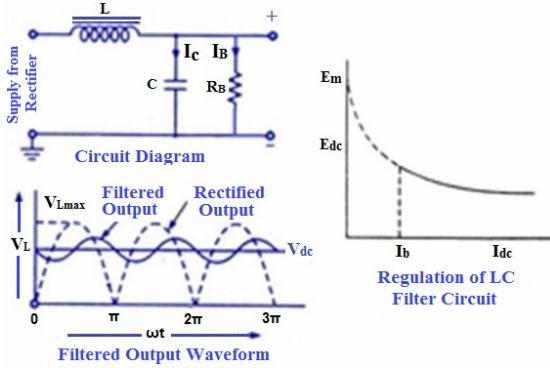

Figure 3: LC filter circuit.

Regulating Loops

3 nos. of regulating loops are used for high stability of the power supply.

- 1) Inner Fast Voltage Loops: This attenuate the output voltage ripple and hum and the output voltage fluctuation due to main supply fluctuation.
- 2) Middle Slew Rate Loop: It ensures an excellent slew rate linearity independent of the load and the set value.
- 3) Outer Slow Current Loop: It ensures the overall stability of the power supply.

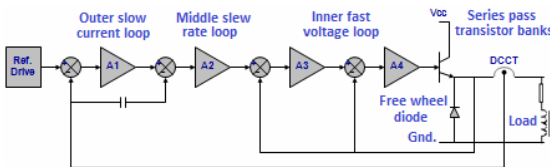

Figure 4: Regulating Loops

- For successful operation of the regulating loops
- All the components used in the circuit are required to be of high precision in nature. All the operational amplifiers used should have low noise and low drift, like OP-27 family.
- Current Transducer working on zero flux principal is used for sensing DC current with 0.001% accuracy.
- Digital-to-Analog converter with true 16 bit resolution, 1 ppm/°C temperature drift and 2ppm noise is used in the reference drive circuit.
- Precision low noise & low temperature drift voltage reference source like REF101 is used in the reference drive circuit.
- All the critical components like DAC, Reference voltage source, burden resistance of the zero flux type current sensor and the error amplifier are enclosed in a Peltier cooler for low temperature drift of those components.

High Precision Current Sensor DCCT

DCCT works on zero flux principal is used for sensing DC current with 0.001% accuracy. The electronic control circuitry is completely isolated from the main power circuit of the power supply and earth for reason of safety and stray current path which produces measurement error. The measuring head, consisting of three identical toroids,

senses the residual field and controls the amplifier in such a way as to keep the net field zero.

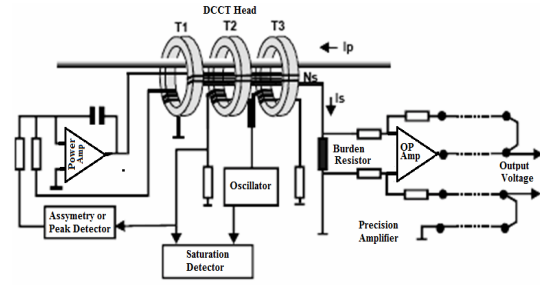

Figure 5: DCCT

A residual flux will cause asymmetry in the magnetizing current resulting in an output voltage fed to the power amplifier in the secondary circuit so that its output current restores perfect flux balance and hence zero residual field.

The secondary current is passed through the burden resistor and the drop across it is calibrated to denote the DC current.

THERMAL MANAGEMENT FOR POWER SUPPLY STABILITY

- Peltier cooler and controller are used to keep the operating temperature of the critical components, mainly error amplifier, DAC and burden resistance of DCCT in the regulating circuit, constant around 35°C slightly above room temperature with 0.2°C accuracy in order to avoid characteristic drift due to temperature variation.

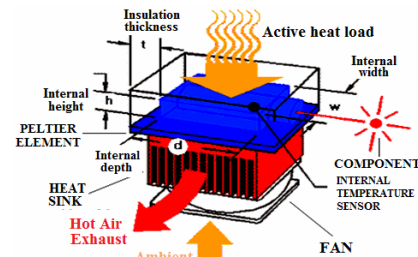

Figure 6: Peltier Cooler

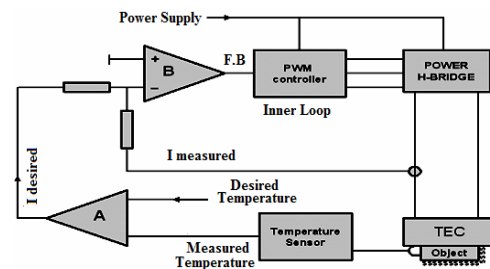

Figure 7: Peltier Controller.

- Low conductivity water cooled heat sinks are used for cooling of power transistors and diodes, small resistor is added to the emitter of each of the transistors in parallel for balance current sharing required for high stability of the power supply.

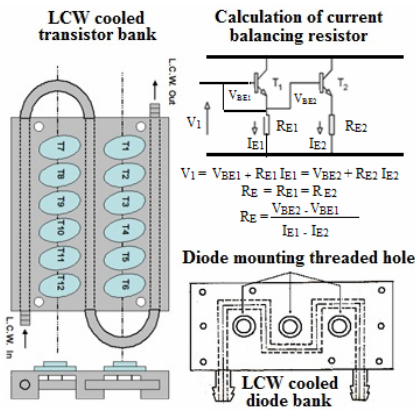

Figure 8: LCW cooled heat sinks

- Pre-regulator System is used to reduce power dissipation in the series pass transistor to improve efficiency and stability of the power supply.

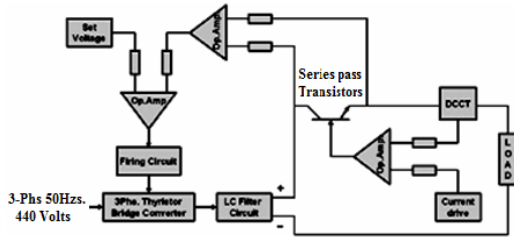

Figure 9: Pre-regulator system

- All the power supplies are placed in an air conditioned environment with temperature around 25°C to 30°C.

R.F. PICK-UP ATTENUATION AND SHIELDING OF POWER SUPPLY

The conducted R.F. pick-up transmitted to P.S. through power cables form magnets in the R.F. field is attenuated with R.F. filter and the radiated R.F. pick-up radiated from the cyclotron chamber is minimized by properly grounding and shielding of the power supply electronics modules and cabinets to improve power supply stability.

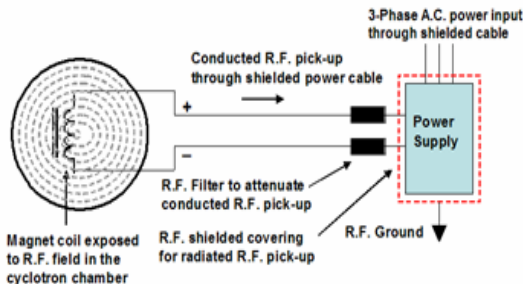

Figure 10: R.F Pick-up Attenuation & Shielding

LINE-INTERACTIVE UPS SYSTEM

This is used to overcome line disturbances. The induction coupling acts as a store of kinetic energy. It handles the line voltage dips, and keeps the generator running before the diesel engine comes into action to run the generator when main power fails. The choke and the synchronous 3-ph. a.c. machine together act as a

stabilizing filter and provide clean regulated power from the mains during normal operation. The 3-ph.a.c. machine acts as a synchronous motor when normal power exists. The diesel engine operates when normal power fails. Then the a.c machine acts as a generator.

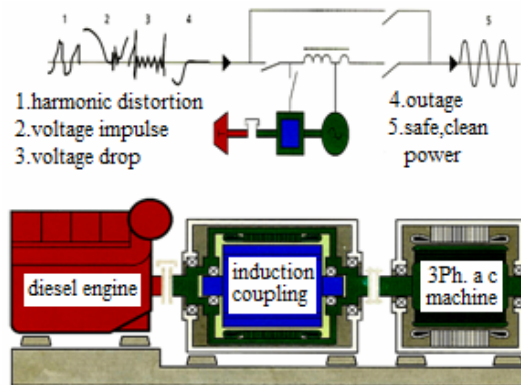

Figure 11: Line Interactive UPS System

PERFORMANCE DATA OF A 5 PPM HIGH PRECISION POWER SUPPLY

Table 2. Performance table

Parameter	ppm
Short term stability: (30min)	3ppm
Long term stability: (8hrs)	5ppm
Line regulation: Ramp or step within ±10% of supply line	0.5ppm
Load regulation: Magnet coil resistance change within ±10%	0.5ppm
Temperature coefficient: (per °C)	
•Ambient temperature variation at P.S. location in the range of 20°C to 30°C	0.2ppm
•Cooling water temperature variation in the range of 20°C to 35°C	0.05ppm
Ripple: Current ripple in magnet	0.15ppm

Stability of a magnet power supply is the net deviation of the load current value from the set value under the condition of +/- 10% variation of input line voltage, load resistance and temperature.

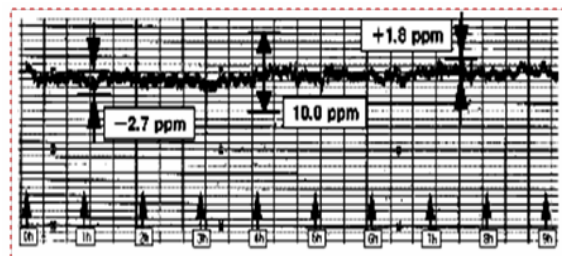

Figure 12: Stability of a main magnet power supply

For the main magnet P.S. (3000Amps.150Volts.) the stability has been calculated to be

$$+ 1.8 \text{ ppm} - (- 2.7 \text{ ppm}) = 4.5$$