

MAGNETIC PROPERTIES OF SILICON ELECTRICAL STEELS AND ITS APPLICATION IN FAST CYCLING SUPERCONDUCTING MAGNETS AT LOW TEMPERATURES

P. Shcherbakov, I. Bogdanov, S. Kozub, L. Tkachenko

Institute for High Energy Physics (IHEP), Protvino, Moscow region, Russia

E. Fischer, F. Klos, G. Moritz, C. Muehle

Gesellschaft für Schwerionenforschung (GSI), Darmstadt, Germany

INTRODUCTION

One needs a complete set of magnetic properties data for electrical steels at operating conditions in order to design accelerator superconducting(SC) magnets. These conditions are: low temperature ($T = 4.5$ K), low frequency ($f < 1$ Hz) unipolar magnetization cycles and high magnetic inductions ($B > 2.0$ T). SC magnets of colliders used low carbon steel to reduce coercive force [1, 2]. Steels for the SIS project have to satisfy three main requirements: low coercive force H_c (in order to have high permeability and low hysteresis losses), high resistivity at low temperature (to decrease the eddy current losses), and high saturation magnetization M_s (to avoid the saturation effects). There are two classes of thin sheet Si-doped electric steels. The designation of steel grade has four digits. The first digit defines the structural state and kind of rolling: 3 means a cold rolled anisotropic grain oriented (GO) steel while 2 means a cold rolled isotropic non-grain oriented (NGO) steel [3, 4]. The second number denotes the silicon content and the third number shows the main certified value; in our case 1 means specific losses at $B = 1.5$ T and 50 Hz. The last digit denotes a modification.

TESTED STEELS

Cold rolled isotropic NGO thin sheet steels of grade 2211-2216, 2312, 2412, M250-50A and anisotropic GO steels 3413 and 3414 were tested. Thickness of all steels was approximately 0.5 mm, with insulation. Chemical composition, density, and power loss during cycles with $B_{max} = 1.5$ T at 50 Hz are presented in Table 1. The steels 2211-2216, 2312 and 2412 were produced by Novolipetsk Metallurgical Center, steel M250-50A by EBG Company.

Table 1: Characteristics of studied steels

Grade	Si, % standard	Si, % measured	C, % standard	γ , g/cm ³	$P_{1.5/50}$, W/kg
3413	2.8-3.8	≈2.8	<0.04	7.6-7.65	1.75
3414	2.8-3.8	≈2.8	<0.04	7.6-7.65	1.50
M250-50A	>3	3.3	<0.004	7.6-7.65	2.50
2211	0.8-2.1	0.94	<0.04	7.80	-
2212	0.8-2.1	1.31	<0.04	7.80	4.07
2213	0.8-2.1	0.53	<0.04	7.80	4.89
2215	0.8-2.1	1.01	<0.04	7.80	4.08
2216	0.8-2.1	1.04	<0.04	7.80	3.82
2312	1.8-2.8	1.33	<0.04	7.70	3.72
2412	2.8-3.8	2.94	<0.04	7.6-7.65	2.91

SAMPLES AND MEASUREMENT SET-UP

Measurements have been made on ring samples with 40-mm inner and 50-mm outer diameter. Accurate thickness values were determined by weighting the samples. The rings were made very carefully by machining on a lathe and were not annealed. Two toroidal copper coils were wound on each sample, which consisted of 10 rings. The inner one layer pickup coil had about 150 turns. The outer three layer magnetizing coil had about 450 turns. Anisotropy of magnetic properties was studied on strip samples with dimensions of 280 mm×29 mm, with the help of an Epstein frame. Strips were cut by guillotine from original steel sheets, in directions along and perpendicular to the steel rolling direction. A diagram of the measurement method is presented in Fig. 2.

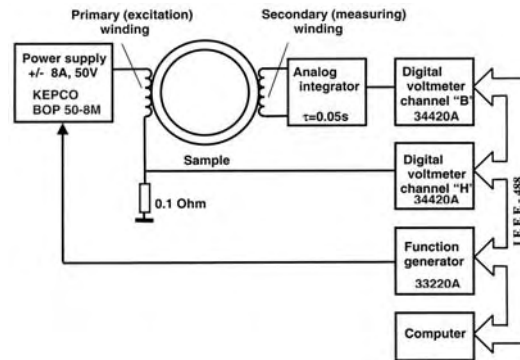

Figure 1: Block scheme of experimental set-up

The H coil is connected to a bipolar operational power supply. Magnetizing force is proportional to magnetizing current:

$$H = \frac{Np \cdot I}{L},$$

where: Np is a number of primary turns, I is a current in primary winding, L is the magnetic path in a sample.

An electronic integrator, attached to the secondary winding, measures magnetic flux induced in the sample. The induced flux, resulting from the variation of the driving magnetic field H , generates a voltage U in the integrator output:

$$\Phi = \frac{U \cdot \tau}{Ns},$$

where: U is the integrator output voltage, τ is the integrator time constant and Ns is a secondary turns number.

A digital voltmeter is used for acquisition of waveforms of signals. A function generator, which controls the power supply, was programmed to produce a triangular magnetizing current in the H-coil. The repetition frequency of current cycles was 0.03, 0.01, 0.005 and 0.003 Hz.

The main magnetic characteristics were obtained from plotted hysteresis B-H loops. Extreme points B_{max} and H_{max} of loops give the B-H curve. Coercive force H_C is found at the intercept of the H-axis with the hysteresis loop. Area, enclosed by hysteresis loop, determines hysteresis loss per cycle. Specific losses were measured in symmetrical cycles, when the magnetic induction was varied between the limits of $-B_{max}$ and $+B_{max}$, and asymmetrical cycles 0 and $+B_{max}$. In last case the magnetizing force was varied between the limits of $-H_C$ and $+H_{max}$. For steel sample 2212 the losses were measured during cycles between B_{min} and $+B_{max}$ for various combinations of B_{min} and B_{max} . The measurements were made at different frequencies and then extrapolated to zero frequency in order to avoid the interference due to effects of eddy currents, generated in the sample body. The static coercivity and hysteretic losses were obtained in this way.

RESULTS AND DISCUSSION

Anisotropy

The B-H curves, obtained on the strip samples for two types of steels, are presented in Figs. 2, 3. The isotropic steel M250-50A has significant anisotropy at magnetizing forces below 1000 A/m ($B \approx 1.4$ T). B-H curve for the steel 3413 is almost the same as for 3414, shown in Fig.3. Hysteresis losses are anisotropic for steels of both NGO and GO classes.

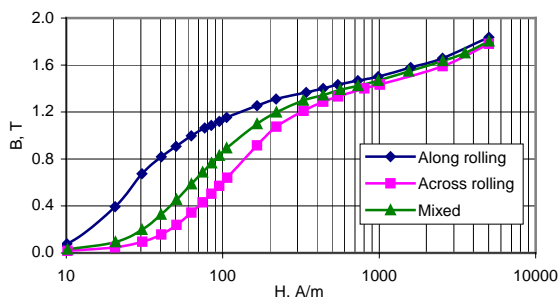

Figure 2: B-H curve anisotropy of M250-50A steel

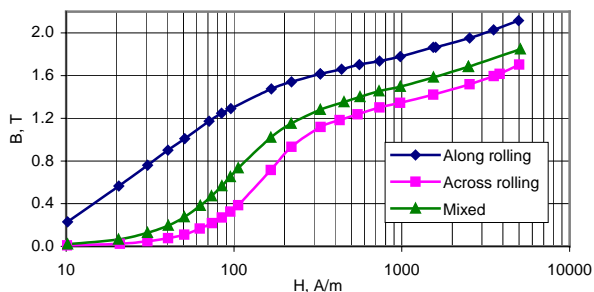

Figure 3: B-H curve anisotropy of 3414 steel

300 K Properties of Steels for SIS300 Dipole

The B-H curves for ring samples of steels 2211 - 2216, 2312 and 2412 at 300 K are presented in Fig. 4.

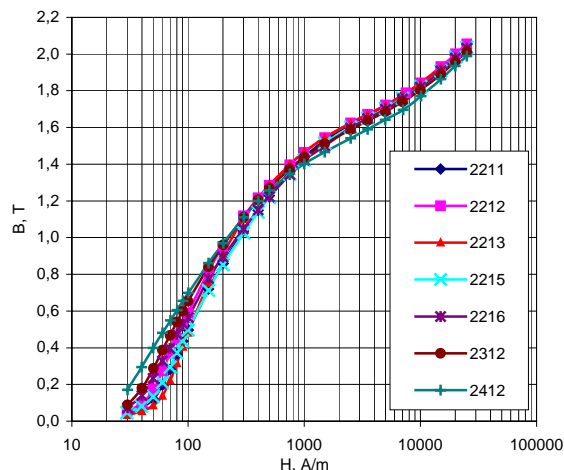

Figure 4: B-H curves of isotropic steels at 300K

Coercive force and losses during symmetric cycles at 0.01 Hz (including the eddy current component) are presented in Table 2. On the basis of these results, the steels 2212 and 2412 were chosen for low temperature measurements, along with the steels M250-50A, 3413 and 3414.

Table 2: Coercivity and losses at room temperature

Grade	H_c , A/m	Losses at 0.01 Hz		
		1 T	1.5 T	1.75 T
2211	68	34.8	70.2	101
2212	65	29.9	65.4	111
2213	78	39	82.2	128
2215	68	33	69.5	103.1
2216	60	28.7	62.2	96.3
2312	55	25.5	59.2	111
2412	41	19	46	113

Low Temperature Properties

The B-H curves for the selected steels, at room and cryogenics temperature, are presented in Figs. 5, 6. Temperature influence on the B-H curves is weak. The coercive forces in the 2212 steel are 65, 70 and 72 A/m at 273, 77 and 4.2 K, respectively. The effect of temperature on coercive force of all steels with 3% silicon content lies within the limits of 3%.

Specific losses for symmetric and unipolar field cycles are presented in Figs. 7, 8. The effects of temperature on losses are small. Losses, measured during unipolar cycles, are necessary to make proper calculations of losses in magnet iron yokes [5], are equal to 0.3 - 0.4 times the losses obtained in symmetric cycles for all studied steels.

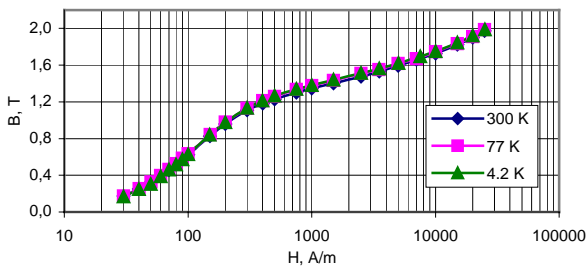

Figure 5: B-H curve for steel 3413

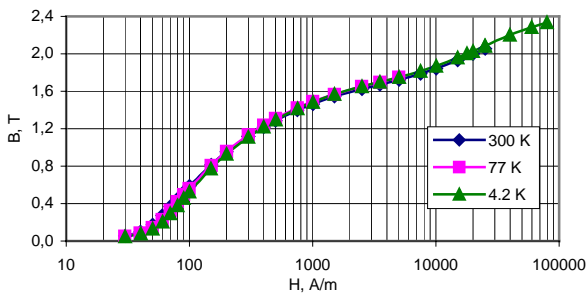

Figure 6: B-H curve for steel 2212

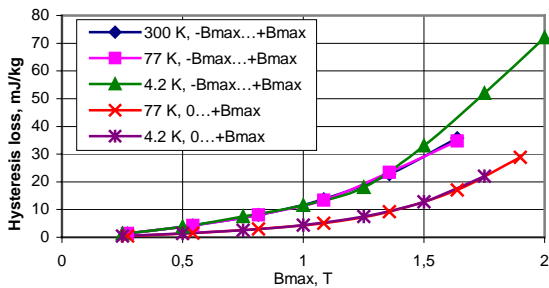

Figure 7: Hysteresis losses in steel 3413

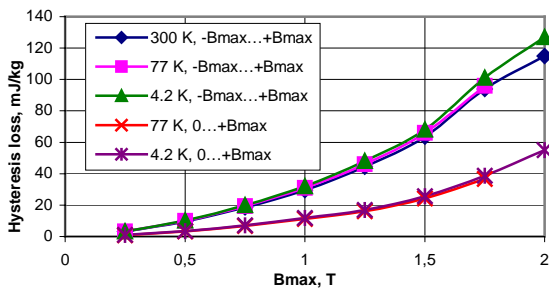

Figure 8: Hysteresis losses in steel 2212

Comparison and Choice of Steels

The hysteresis losses between 0 and $+B_{max}$ cycles are presented in Fig. 9. The losses for is NGO and GO steels with 3% Si differ a little in the induction region above 1.8 T. There are not evident advantages of anisotropic steels. The steel 2212 has higher losses than the steel 2412, but also higher saturation magnetization M_s . The last reason is very important for field quality. So, this steel is recommended for use in the SIS300 model dipole. To facilitate calculations of iron yoke losses in the SIS300 dipoles [6] during a central field rise from 1.6 T to 6 T, hysteresis losses have been measured for partial cycles with differ-

ent B_{min} and B_{max} , as is realized in the magnet yoke. Losses for such cycles are presented in Fig. 10. Calculation of losses in the iron yoke of the SIS300 dipole, using data corresponding to operating conditions, gives about 40 J/m.

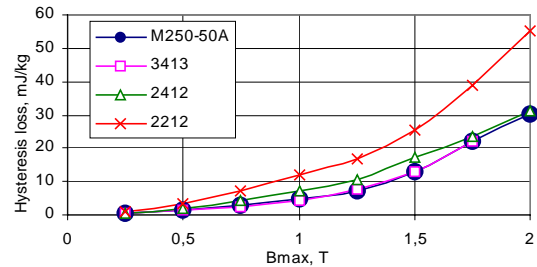

Figure 9: Hysteresis losses in unipolar cycles $0 - B_{max}$

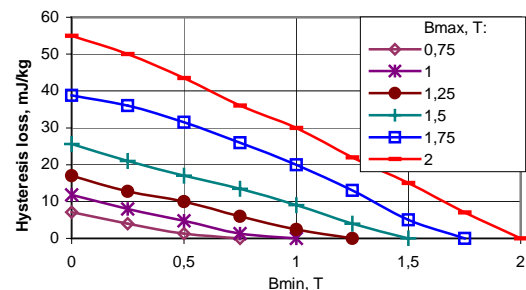

Figure 10: Losses in steel 2212 in partial cycles

CONCLUSIONS

The studied steels have anisotropic magnetic properties. Temperature has a small effect on magnetic properties of silicon steels, so that the room and liquid nitrogen temperature data can be used for calculations of field and hysteresis loss in magnets. Steels with 3% Si have a similar hysteresis losses for cycles between 0 and $+B_{max}$ cycles. Steel 2212 is recommended for use in the yoke of the SIS300 model dipole. A final decision, regarding the use of this steel should be made after the testing of a model dipole.

REFERENCES

- [1] S. Kawabata, "Magnetic Permeability of the Iron Yoke in High Field Superconducting Magnets", Nuclear Instruments and Methods in Physics Research A329, 1993, pp. 1-8.
- [2] R. Thomas and G. Morgan, "Measurements of Magnetic Permeability and Hc of Magnet Steels Using Digital Techniques", BNL report, 1992.
- [3] Cold-Rolled Electrical Steels, Reference book, Ed. B.V. Molotilov, Metallurgy, Moscow, 1989.
- [4] J.J. Gniewek and E. Ploge, "Cryogenic Behavior of Selected Magnetic Materials", Journal of research of the NBS-Engineering and Instrumentation, vol. 69C, no.3, July-Sept. 1965, pp. 225-236.
- [5] I.V. Bogdanov and P.A. Shcherbakov, "AC Losses in the Iron Yoke of Superconducting Magnets of UNK", Proceedings of XVI All-Russian PAC, IHEP, Protvino, 1998, v. 2, pp. 45.
- [6] L. Tkachenko et al. "Comparison of Three Designs of a Wide Aperture Dipole for the SIS300 Ring", This conference.