

A SMALL 1 MeV ELECTRON ACCELERATOR FOR MEASURING HEAVY METAL CONCENTRATIONS IN SMOKESTACK GASES

A. Reppond, M. Ambrosia, B.C. Hansen, C.R. Meitzler[†], D.P. Redden, Sam Houston State University, Physics Dept., 1902 Ave J., 202 Farrington Bldg., Huntsville, TX 77341, USA and D.A. Swenson, Linac Systems, Waxahachie, TX, USA

Abstract

A low-current electron beam may be used as a diagnostic tool to measure the concentrations of heavy metals (Pb, Hg, Sb, etc.) present in the flue gas particulates produced by smelters or cement kilns. A small electron accelerator is being constructed as part of a prototype emissions monitoring system. The electron beam energy has a design energy of 1 MeV, a peak current of 5 mA, and a duty factor of 0.1 percent. In this paper, we discuss the results of a set of EGS4 calculations used to model the transport properties of a 1 MeV electron beam passing through a thin vacuum window and the flue gas.

1 INTRODUCTION

Heavy metal pollutants (e.g. Pb, Hg, Cd, Sb, As, and Be) are released through normal industrial processes such as cement manufacture, mercury refining, lead refining and recycling, and municipal trash incineration. The total amount of pollution can be estimated from annual production figures [1]. For example, the total world mine production of mercury in 1994 was 1,760 tonnes.[1] Most of this mercury will eventually return to the environment as some form of pollution. Once in the ecosystem, the metal will tend to accumulate in living organisms. Similar statistics exist for the other metals in the list, above.[2]. Due to the toxic nature of these pollutants and the health risks associated with long-term low-level exposure, there has been a desire to produce a multi-metal Continuous Emissions monitor (CEM) that can measure the quantities of these metals released at their source.

One promising analytical technique for a CEM is Particle Induced X-ray Emission (PIXE)[3]. This analytical technique observes the characteristic K and L-shell x-rays emitted by atoms that are ionized by the passage of high-energy charged particles. As the atom relaxes back to its ground state, it emits a characteristic x-ray spectrum. PIXE's power as an analytical technique is that it can easily measure sub-ppm elemental concentrations without substantial interferences from other elements that may be present.

In the following paper, we describe a conceptual design for an electron linac-based CEM. A brief description of the monitor will be presented. Finally, a

discussion of the external beam dynamics will be presented.

2 CEM SYSTEM OVERVIEW

2.1 Conceptual Design

We have developed a conceptual design for an electron linac based CEM shown in Figure 1. A small electron linac is mounted at a convenient location on the side of a smokestack. The microwave source, high-voltage, pulse counting, and control electronics are mounted nearby in an enclosed rack.

The CEM's operation is straightforward. An electron beam is accelerated to an energy of approximately 1 MeV. After acceleration, the beam passes through a thin window into the gases inside the flue. As the accelerated electrons pass through the flue gas, they ionize it. The ionized atoms then relax to their ground states by emitting characteristic x-rays. A solid state photon detector observes the fluorescence x-rays. The density of the atoms is calculated from the background subtracted spectrum.

2.2 Accelerator Requirements

The beam energy for the accelerator was determined from three requirements. First, the beam particles must be able to penetrate through a window into the flue gas and have a range of 1 m in air so that they clear the observation region before stopping. Second, the electrons must have

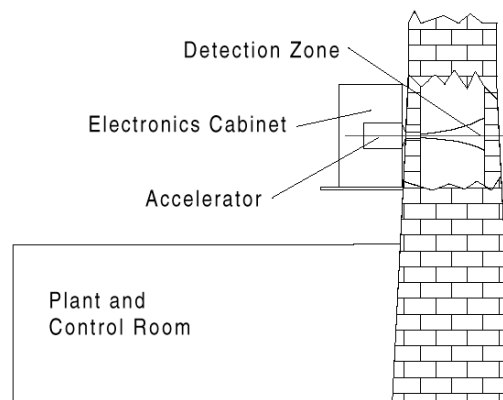

Figure 1 Conceptual design of the CEM. The accelerator is mounted on the side of a smokestack. The beam and interaction region are shown.

[†] corresponding author

enough energy in the observation region to create K-shell vacancies in the metals we wish to observe. (Table 1). Finally, the beam energy must be below 1.6 MeV to avoid creating radioactive material in the flue gases.

The beam current specification is obtained by considering the measurement cycle time, minimum detection limit, and maximum count rate in the detectors. We have assumed that the measurement cycle will be 900 seconds, the detection limit for lead or mercury was chosen to be a modest 1 $\mu\text{g/g}$, and the maximum count rate set to 200 Hz. This leads to a peak current of 5 mA.

Table 2 Accelerator specifications

Overall

Projectile	e-	
Beam energy	1	MeV
Peak beam current	5	mA
Pulse width	5	μs
Repetition rate	200	Hz

Linac

Low structure	DLG	
High structure	PWT	
Operating frequency	2.88	GHz
Peak structure power	46	kW
Peak beam power	5	kW
Overall length	56	cm

Electron Gun

Extraction voltage	29.5	kV
Cathode/anode voltage	05	kV
Grid cutoff voltage	-25	V
Filament Current	1	A

2.3 Linear Accelerator

The linear accelerator consists of two separate structures that are closely coupled together: a disc-loaded waveguide (DLG) for the low- β section and a plane wave transformer (PWT) [4] for the high- β section. This combination of structures results in an accelerator that is compact, light-weight, self-contained, and has good microwave power. The length of the complete linac is 56 cm.

The low- β section of this accelerator is a structure that integrates both a half-cell rf electron gun and DLG into one piece. The first half-cell forms the rf electron gun. Immediately after the electron gun are four cells that provide the main acceleration for this part. The last half-cell is designed to be abnormally short to adjust the phase for transit through the PWT section. The average accelerating field is set to 4.84 MeV/m. The peak power needed for this section is 36 kW. Power is coupled into the waveguide by an iris separating the DLG from the PWT.

The high- β section of the accelerator is a PWT structure operating in a standing wave, TEM mode. The

TABLE 1 Characteristic x-rays of selected metals. All energies are in keV. The elements listed are those covered as BIF metals by the US Environmental Protection Agency.

<i>Element</i>	<i>Z</i>	<i>Kα</i>	<i>Lα</i>
Be	4	0.109	
As	33	10.544	1.282
Cd	48	23.174	3.134
Sb	51	26.359	3.605
Hg	80	70.818	9.989
Pb	82	74.969	10.551

average accelerating field of this section is 2.42 MeV/m with a peak structure power of 11 kW. The length of the PWT is 30 cm. The open aperture in the nose cones is 2 cm.

A set of four rods support the electrodes of the PWT. These rods are hollow and provide a channel for cooling the inner electrodes. The outer shell of the PWT is not cooled directly. Since we can expect the outer shell of the CEM to be exposed to large temperature variations during normal operation, we have used SUPERFISH to investigate the frequency stability of the PWT when the inner electrodes are maintained at a constant 20 C but the outer shell is allowed to vary over a temperature range of 0 C to 30 C. We found that the frequency change was less than 10 kHz, which is well within the pulling frequency of most magnetron tubes.

2.4 Electron source

The electron gun for this accelerator is an integral part of the first half-cell of the low- β section. The electron source is a modified EIMAC 8745 planar triode tube. The tube is modified by removing the anode cooling fins and cutting through the vacuum tube to expose the grid and cathode. The exposed cathode/grid structure is mounted directly in the rf gun prior to operation. A separate high-voltage system is used to power the electron source. Modulation is provided by pulsing the grid voltage.

2.5 Microwave source

The microwave power source for this accelerator was designed to be as simple as possible. A high-voltage power supply charges the capacitors in a simple 6-stage PFN to 24 kV. A Behlke HTS-301 solid state switch is used to modulate the high-voltage applied to the cathode of the magnetron tube. The magnetron's microwave output is coupled to the accelerator 7/8" coaxial components. A schematic of the microwave system is shown in Figure 2.

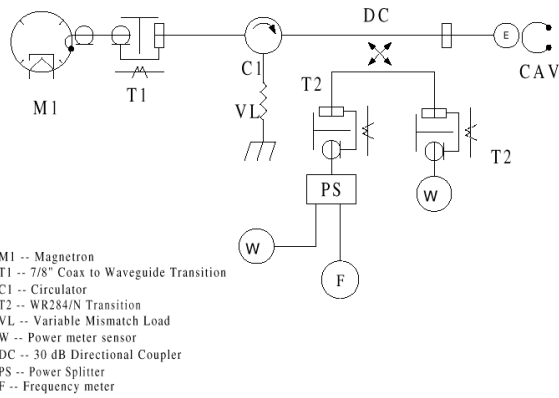

Figure 2. Schematic of the coaxial line linking the magnetron source to the

3 PASSAGE OF ELECTRONS THROUGH GAS COLUMN

We have modeled the passage of the electrons through the exit window and gas column using the EGS4 code. [5]

3.1 Power loading on exit window

In this study we used a single non-vacuum region through which the particles passed. The code was set up so that the energy deposition was tallied for each particle as it passes through the foil. Furthermore, we allowed secondary electrons and x-rays to deposit as they passed through the foil. Two materials were studied: Al/Be and amorphous diamond. Figure 3 shows the results of this calculation. For foils greater than 0.3 mm thickness, the amorphous diamond absorbed less than half of the beam energy and produced substantially less bremsstrahlung radiation: 7% of the beam energy for carbon versus 14% for Al/Be. Finally, amorphous diamond is both a good thermal and electrical conductor, and is mechanically strong.

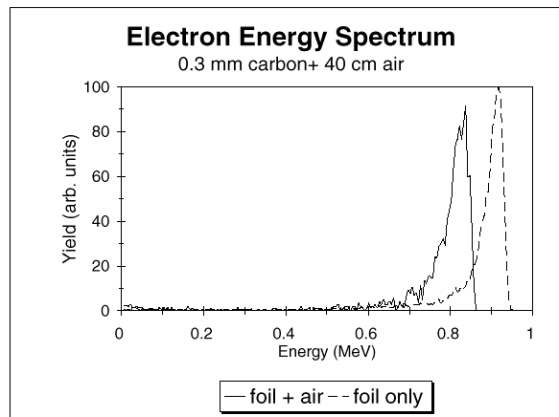

Figure 4. Typical energy spectrum of 1 MeV electrons passing through 0.3 mm of diamond and 40 cm of air.

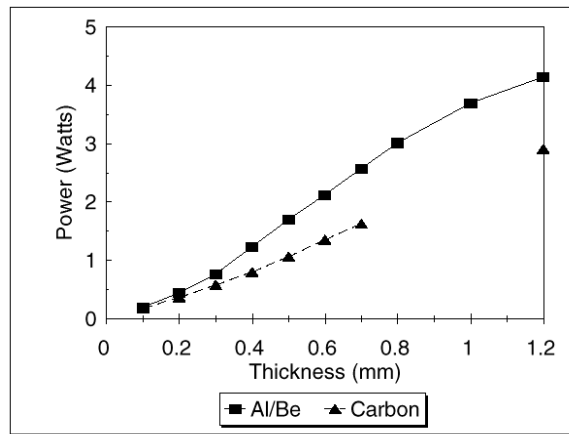

Figure 3. Fraction of beam power absorbed by the diamond foil. The average beam power is 5 Watts with a peak beam power of 5 kW.

3.2 Electron Energy Spectrum

A second EGS4 model was constructed to investigate the energy loss as a function of the distance that the particles penetrated through the gas. Figure 4 shows a typical energy spectrum as the particles pass through both an exit window and 40 cm of air. The "beam energy" loses approximately 100 keV in each region. 40 cm of air is shown in Figure 4.

5 CONCLUSION

A small 1 MeV accelerator can be built that can be used as an electron source for a multi-metal CEM. A diamond exit window will be employed to minimize bremsstrahlung. A 1 MeV beam has sufficient energy to create an observation region that is more than 40 cm in length.

6 ACKNOWLEDGEMENTS

This project is supported by the Advanced Technology Program of the Texas Higher Education Coordinating Board under grant number

REFERENCES

- [1] U.S. Bureau of Mines, *Minerals Yearbook* (1994).
- [2] U.S. Bureau of Mines, *Minerals Yearbook* (1994).
- [3] A.F. Oluwole, et. al., "Characterization of Airborne Particulate from a Lead Smelter by PIXE and EDXRF," *Nucl. Inst. Meth.* (1995)
- [4] D.A. Swenson, "The Plane Wave Transformer Linac Structure," *Proceedings of the European Particle Accelerator Conference*, Rome, Italy (Editions Frontiere, Gif-sur-Yvette, 1988) p. 1418.
- [5] W.R. Nelson, H. Hirayama, and D.W.O. Rogers, "The EGS4 Code System," SLAC-Report-265, Stanford Linear Accelerator Center, December, 1985.