

GAP VOLTAGE FEED-FORWARD MODULE FOR PEP-II LOW LEVEL RF SYSTEM*

W. Ross, R. Claus, L. Sapozhnikov
Stanford Linear Accelerator Center, Stanford, CA 94309, USA

Abstract

The Gap Voltage Feed-Forward (GVFF) Module produces adaptively generated inphase (I) and quadrature (Q) reference signals for a single RF station. This module measures the periodic (1-turn) beam induced cavity transients caused by the presence of an ion clearing gap in the beam. A reference waveform is generated to minimize the direct feedback error signal transient caused by the gap. In addition, the GVFF module receives a fiber-optically connected, band-limited 'kick' signal from the Longitudinal Feedback System. The kick signal modulates the I and Q components of the RF reference causing the station to act as a 'sub-woofer' for the Longitudinal Feedback System. This process dampens low order coupled-bunch instabilities induced by the fundamental mode of the accelerating cavities. The GVFF Module also includes hardware for remote measurement and adjustment of the 'kick' transfer function.

1. INTRODUCTION

The Gap Voltage Feed-Forward (GVFF) Module is a C-size VXI circuit board which is installed in a 13-slot VXI Chassis containing the various modules of the Low-Level RF system [1]. An RF Station consists of this VXI chassis, a safety interlock chassis, a klystron, an RF drive amplifier, and either two RF cavities for Low Energy Ring (LER) stations or four RF cavities for High Energy Ring (HER) stations. The PEP-II B-Factory contains five RF Stations for the HER and three RF Stations for the LER. The RF Stations are positioned around the 2200 meter circumference ring as shown in Figure 2. There is one GVFF module in each RF Station.

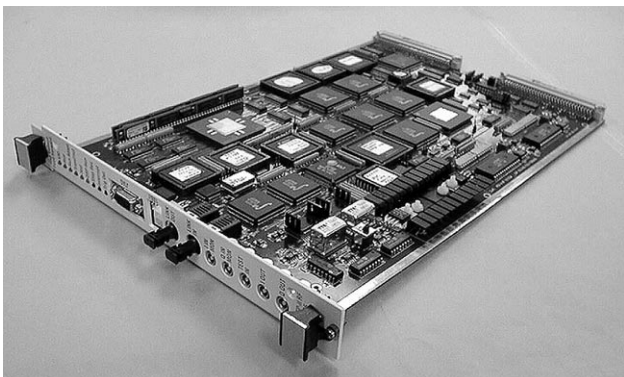

Figure 1: Photograph of GVFF module.

The primary function of the GVFF module is to generate a periodic reference signal which sets the amplitude and phase for the 476 MHz klystron RF drive signal. The desired amplitude and phase for each RF Station is defined in an EPICS data base which can be read by a DSP processor in the GVFF module. The reference signal is a two dimensional signal of I (in-phase) and Q (quadrature) components. Its period corresponds to one turn through the ring, or 7.34 μ Sec.

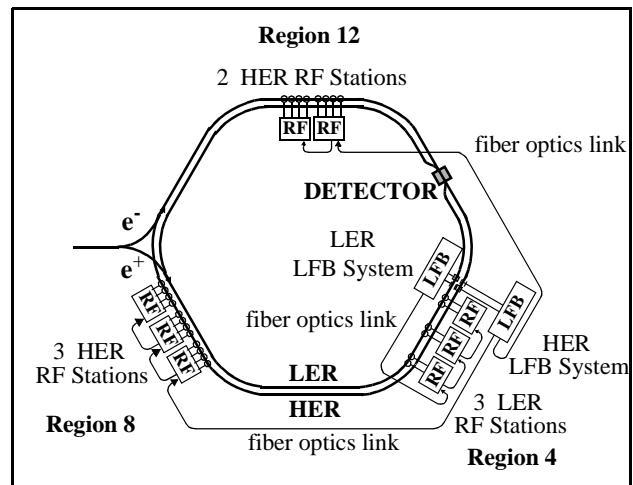

Figure 2: Interconnect between RF Stations and Longitudinal Feedback Systems.

Figure 3 shows the direct feedback loop of an RF Station. The stored circulating beam in either ring consists of a series of electron or positron bunches and an unfilled area called an ion clearing gap. When the gap passes through the cavities, a large voltage transient occurs which would normally saturate the feedback loop. The GVFF module monitors the direct feedback loop error signal to detect the periodic gap transient. The GVFF module applies an adaptive digital signal processing algorithm to generate a reference waveform which combines the EPICS specified amplitude and phase for the RF station (DC component) with a 'gap transient' compensating waveform (AC component) to minimize the gap transient as seen in the loop error signal.

The secondary purpose of the GVFF module is to interface the LLRF systems and the Longitudinal Feedback (LFB) system for each ring. Two LFB systems are installed in Region 4 of the PEP-II B-Factory, one serving the HER and one serving the LER. These LFB systems dampen the coupled bunch synchrotron oscillations which are driven by parasitic higher-order modes of the RF cavities.

*Work supported by Department of Energy, contract DE-AC03-76SF00515

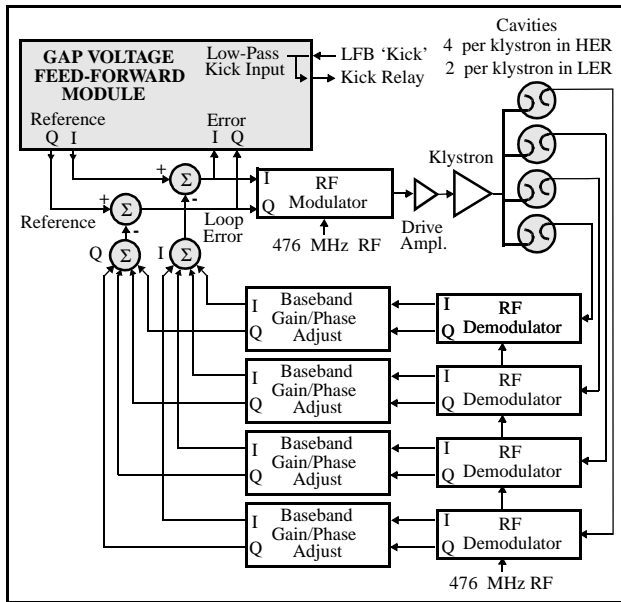

Figure 3: Block diagram of direct feedback loop for one RF Station.

The LFB Systems use their own ‘kicker’ arrays to dampen the higher-order mode oscillations. However, to dampen the larger low-order mode oscillations, each LFB system low-pass filters its analog kick signal, digitizes it and transmits it to the RF Stations via fiber optics cables, as shown in Figure 2. The RF Stations serve as high-power, low frequency drivers for the LFB systems. The GVFF modules act as interfaces between the LFB sys-

tems and the LLRF systems. The GVFF module transforms the kick signal by means of a cosine table and a sine table, so that $\text{Cos}(\text{kick})$ and $\text{Sin}(\text{kick})$ signals are applied to the real and imaginary inputs of a complex multiplier. The complex multiplier modulates the reference I and Q signals to vary primarily the phase of the klystron drive RF signal.

The GVFF module also measures the open and closed loop responses of the LLRF/LFB loop. A 512K word ‘play’ memory is loaded via the EPICS control interface with a stimulus signal. On demand of the EPICS control interface, the play memory plays out the stimulus waveform, while a ‘record’ memory collects the ‘kick’ waveform samples received from the LFB system. For open loop response, the stimulus signal replaces the LFB kick signal in driving the Cosine/Sine transform. For closed loop measurement, the stimulus signal is added to the LFB kick signal to drive the Cosine/Sine transform. The loop response can be tuned via a programmable 32-tap equalizing filter in the GVFF module.

2. ARCHITECTURE

Figure 4 shows a block diagram of the GVFF module. The digital signal processor (DSP) operates at slower than real-time in computing the reference waveform. Therefore, a pair of 512 word Input FIFOs are used to collect up to 3 turns of error waveform, initiated by a ‘Turn Trigger’ pulse which occurs once per turn. When the FIFOs have data available, the DSP is interrupted. The DSP reads the error signal data from the FIFOs and inputs this to its adaptive

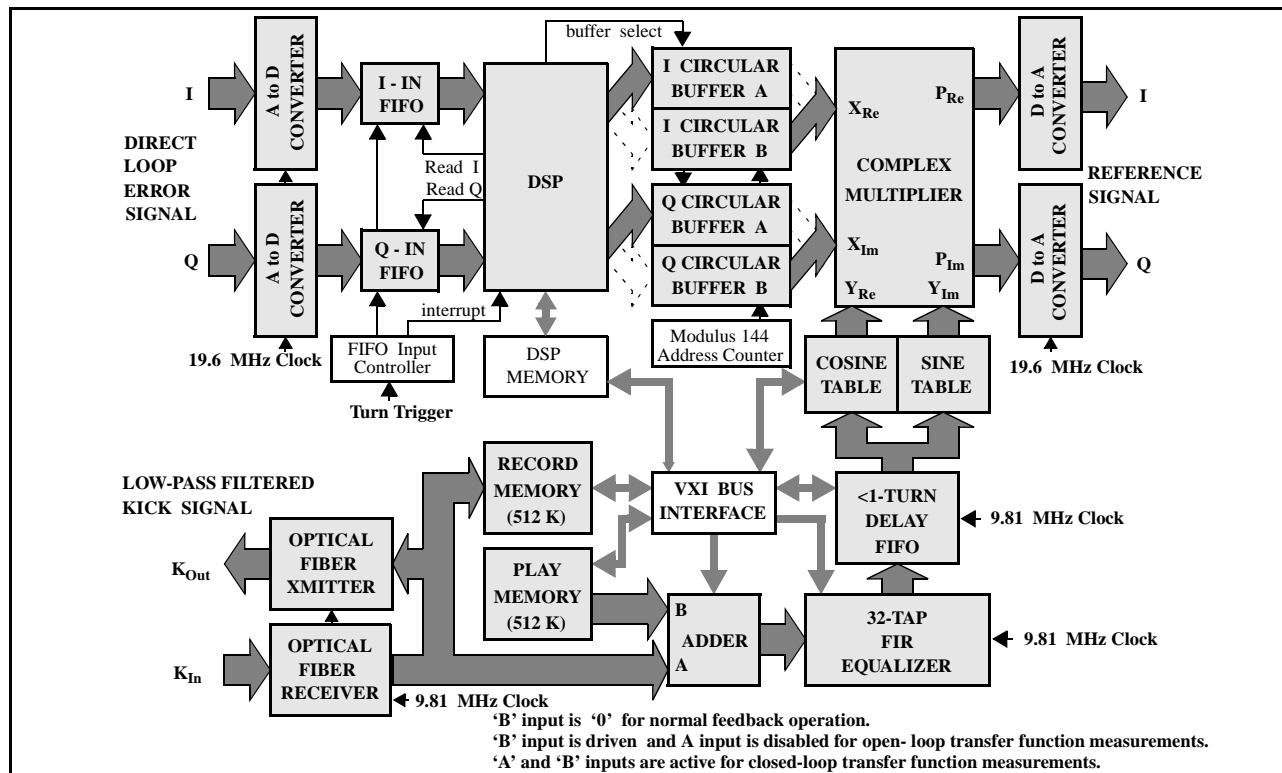

Figure 4: Block diagram of Gap Voltage Feed-Forward Module.

algorithm which calculates one turn of 'reference' waveform. The result is placed into the inactive region of the circular buffers. The DSP then toggles the buffer selector to put the new reference waveform 'on-line'. The DSP begins the next iteration of its adaptive process by re-arming the Input FIFO controller.

The circular buffers repetitively play out the latest reference waveform, on a one-turn period. This reference waveform is then modulated by the LFB kick signal via the complex multiplier.

The low-pass filtered kick samples from the LFB system drive one input of the digital adder. The other input of the adder is driven from the 'play' memory. Either input may be disabled by the EPICS control interface to put the GVFF module into normal feedback mode, open loop transfer function measurement mode or closed loop transfer function measurement mode. The 'equalizer' is a programmable 32-tap FIR filter. It is required to correct kick signal phase distortion induced by the low-pass analog filter in the LFB system. The Delay FIFO time-delays the kick signal so that the delay due to the position of the RF station in the ring and the sum of data processing delays add up to exactly one turn. The Cosine/Sine tables convert the kick signal to I/Q components to cause primarily phase modulation of the station RF drive signal.

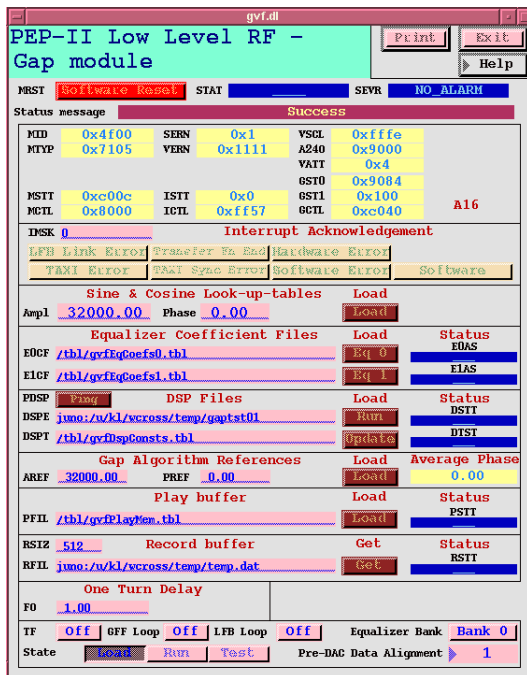

Figure 5: EPICS panel for Gap Voltage Feed-Forward Module control.

3. CONTROL

The various modules in the Low-Level RF System are controlled by EPICS control panels [2]. The EPICS shell runs on a remote workstation and establishes network connectivity to the XVI Control Processor in each of the

LLRF VXI chassis. The control panel for the GVFF module is shown in Figure 5. Controls are provided for loading equalizer filter coefficients, down-loading or reading back the Record and Play memories, loading and starting DSP programs, loading the Cosine and Sine tables, setting the loop delay value, and setting the GVFF module into its various operating modes.

4. ADAPTIVE ALGORITHM

The DSP adaptive algorithm used to generate the reference waveform is outlined below:

- Arm Input FIFO and wait for 'data ready' interrupt.
- Average across the N turns of collected error signal data to compute one turn of 'averaged' I and Q error signals.
- Remove the DC components from the I error signal and the Q error signal:

$$\text{NewErr}_I[0..n] \leq \text{NewErr}_I[0..n] - \text{DC}_I$$

$$\text{NewErr}_Q[0..n] \leq \text{NewErr}_Q[0..n] - \text{DC}_Q$$
- Compute difference equations using constants α (forgetting factor) and β (adaptive rate):

$$Y_I[0..n] \leq \alpha * (Y_I[0..n] + \beta * \text{NewErr}_I[0..n])$$

$$Y_Q[0..n] \leq \alpha * (Y_Q[0..n] + \beta * \text{NewErr}_Q[0..n])$$
- Get 'AREF' and 'PREF' (station amplitude and phase) parameters from the EPICS data base, and convert to I_{ref} and Q_{ref} .
- Compute the new Reference waveform, placing the result into the inactive regions of I circular buffer and Q circular buffer:

$$\text{NewReference}_I[0..n] \leq Y_I[0..n] + I_{\text{ref}}$$

$$\text{NewReference}_Q[0..n] \leq Y_Q[0..n] + Q_{\text{ref}}$$
- Toggle the ping-pong circular buffers to put the new reference signal 'on-line', and loop back to top.

5. GVFF MODULE TEST CAPABILITY

A set of test programs has been developed for the GVFF module, and a tester board has been built which generates a synchronized 'kick' test pattern, feeding this to the GVFF module through a fiber optics link. To facilitate testing, the GVFF module includes an additional data path from the complex multiplier output to the 'record' memory (not shown in Figure 4). This allows most of the GVFF module to be tested in an automated manner.

6. REFERENCES

- [1] P. Corredoura et. al. "Low Level RF System Design for the PEP-II B Factory", SLAC-PUB-95-6855, Oct 1995, Stanford Linear Accelerator Center, Stanford, CA 94309, USA.
- [2] S. Allison et. al., "Operator Interface for the PEP-II Low Level RF System", this conference (PAC 97).