

SUPERCONDUCTING SOLENOIDS FOR THE POLARIZED ELECTRON SPIN CONTROL SYSTEM OF THE MIT-BATES SOUTH HALL RING (SHR)

R. Averill, K. Dow, J. Dzengeleski, C. Sibley MIT-Bates;
 Y. Shatunov, P. Vorobiev, P. Klimine, A. Smirnov, Budker Institute of Nuclear Physics.

I. INTRODUCTION

A scientific collaboration between MIT-Bates and the Budker Institute of Nuclear Physics (BINP) has produced a design for a magnetic insertion, aka "Siberian Snake", into the SHR lattice, which allows for spin control of 0.3 to 1.0 GeV polarized electron beams for planned internal and external target physics. This report describes the design, construction and testing at BINP and the final testing at MIT-Bates for the two superconducting solenoids, which make up part of the "Snake". The solenoids each have the following specifications for 1.1

quadrupole with a $L_{eff}=0.5$ meter. Alternatively, the solenoids could be placed on the extraction line and be used for spin control of the extracted polarized electron beam should the SHR be operated simply as a stretcher ring. See Figure 1 for elevation view of the insertion.

II. DESIGN PARAMETERS

Mechanical specifications concerned the physical size of the units and the limitations of the space available in the SHR tunnel for the insertion to be installed easily. Since the tunnel has a height limitation of 120 inches and the overall length of the insertion was to be minimized, the maximum field was specified to be 7.27 Tesla and allow the standard 2.5 inch diameter beam pipe to pass through with a radial clearance of about 3 mm. The stray field was specified to be <10 Gauss at 1 meter from the ferromagnetic shield, which encloses the cryostat for the solenoid coils. A special BINP designed support stand allows each unit to be assembled and installed before raising the solenoid to the SHR beam height of 54" above the tunnel floor.

Magnetic specifications were set to operate the solenoids at up to 300 A. The solenoidal field is produced by five shorter (160mm long) solenoids assembled on a fixed mandrel and connected electrically in series. See Figure 2.

The superconductor is wound under a pretension so that the coils are in compression when unpowered and use both sides of the increased strain range available when powered fully. The field varies along the axis as in Figure 3.

The number of turns of the 0.87 mm diameter conductor wound on each sub coil is about 3170 turns over 17 layers and the solenoid total inductance is calculated to be

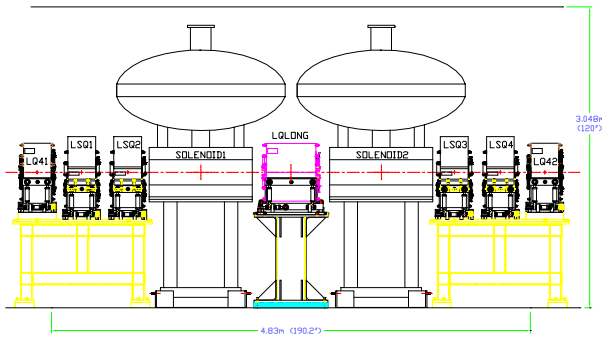

Fig. 1. SHR proposed layout of solenoids

GeV polarized electron spin manipulation; 7.0 cm dia. warm bore, LOA of 104 cm, B_z (max) of 7.27 Tesla @290 A and an integrated axial field strength of 5.764 Tesla-meter @ 290 A. The magnetic insertion is 4.8 meters long and consists of two pairs of skew quadrupoles each with $L_{eff}=0.3$ meter and a central

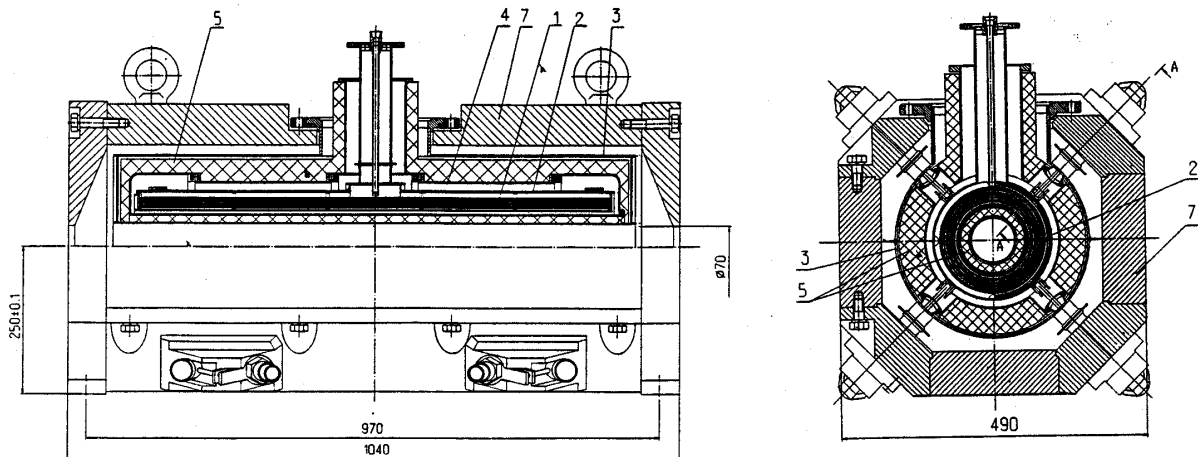
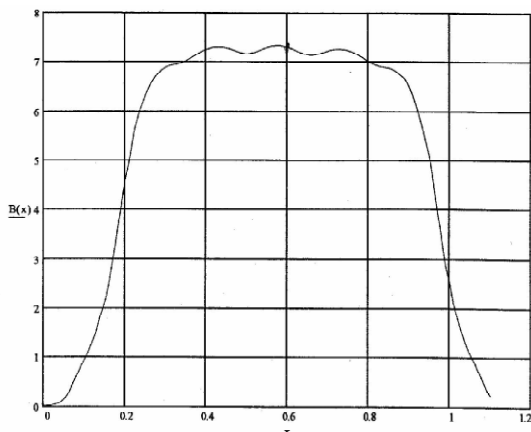

Fig. 2. Superconducting Solenoid (side and end view).



$$\int_0^{1.14} B(x) dx = 5.75 \text{ T m}, I = 290 \text{ A}$$

Fig 3. Solenoid $B(x)$ vs. x ; $B(x)$ = tesla, x = meter

4.5 Henry. The magnetic shield is made of a low carbon steel and also serves to support the internal components. The magnetic forces between the coils and the shield is exactly zero provided all subcoils have the same excitation. In a quench scenario studied for a single subcoil the solenoid suspensions easily handle all unbalanced axial forces. BINP technical staff calculated the magnetic fields and forces using a software called MERMAID. MIT-Bates independently had the fields and forces calculated using the software program called ANSYS. The agreement between the programs was excellent and is the basis for the approved magnetic design.

Cryogenic specifications included only liquid helium be used for the cooldown and operating the coils in the superconductive state. The boil off rate for LH2 was set at < 1.38 Liters/hr (1 watt) for each solenoid. The rate measured in testing so far has been about 1.2 watts, but the systems may not have reach final equilibrium during those short test periods. The design includes a storage dewar which attaches to the solenoid cryostat from above and has an ellipsoidal shape to allow the volume of about 400 liters to be fit into the SHR tunnel.

Quench protection circuitry was designed to bring out some of the energy stored into external resistors by a means of a discriminator circuit that looks at the voltage across the coils and inserts a resistance if the voltage is above a preset level. This circuit includes the subcoil leads (10) being brought out of the cryostat and connected in a way that reduces the quench energy in the cryostat and the amount of LHe that is boiled off during a quench. Several quenches imposed by the designers during testing demonstrated this approach to work well. The storage cryostat when connected as designed to the solenoid cryostat allows LHe to be fed to the bottom of the solenoids during cooldown, but after a level is established above the solenoid, the tube feeding the LHe is withdrawn a few cm and then fills the upper storage dewar. All leads into the solenoid enter through the top of the storage dewar and have a relatively long thermal path between room temperature and LHe temperatures.

Controls and Instrumentation specifications included the power supplies to be supplied by MIT-Bates. Controller for the power supplies were also of the standard type in use at MIT-Bates. Collaboration between the electrical engineers of the two laboratories allowed this interface to be jointly designed so that preliminary testing could take place at BINP and then at MIT-Bates using the final power supplies selected. All internal instrumentation for monitoring temperature of the coils, the copper shields of the solenoid cryostat and the storage dewar were required to be redundant to insure alternate monitors be available should one fail. Carbon resistors were used to measure the temperature of the coils and platinum resistors are used to measure the 90k temperature of the heat shield screen at several places. There is a pressure transducer which samples the pressure in the cryostat. Four Hall probes are installed inside the ferromagnetic shield and provide a measurement of 73 mv/Tesla and is proportional to the axial field, which is linear with current. All controls and instrumentation have been designed to be compatible with the SHR computer system known as the RCS. At this time only one set of controls exists at MIT-Bates in December 1996. Plans are to complete the controls system for the second solenoid system and run both systems again for training and magnetic field measurements at more levels than earlier measured.

III. MEASUREMENTS AT BINP

MIT-Bates technical staff visited BINP in June 1996 and witnessed factory acceptance tests over a 10 day period for the two solenoid systems. A full set of planned measurements was taken for both systems and the factory acceptance testing was successfully completed without any significant problems.

Cooldown measurements indicated that about 60-80 liters of LHe was necessary to bring a single cryostat's internals to the 4.2 Kelvin level. Additional cryogen then began filling the storage dewar above the solenoid to a level sufficient to operate the unit for several days. A limitation in the availability of LHe caused the tests to be run in series for the two solenoid systems, but both behaved similarly during their respective cooldowns. Some effort was expended to determine the boil-off rate of LHe and using a gas meter over a period of time the volume of liquid gas boiled off was determined to be about 1.6 liters per hour or 1.2 watts, exceeding the specification by about 20%. Later measurements on the loss rate could be somewhat lower since the system had not reached its final thermodynamic equilibrium during the testing period. Pressure and resistive temperature sensors monitored the status of the cryostat during the cool down to 4.2 Kelvin. The resistance of the solenoid leads was monitored by a meter in order to verify the state of the coil as it was cooled.

Axial field measurements were made every cm along the full solenoidal field extent at various currents. See Figure 3. A similar plot was taken parallel to the on axis field at $r = 1.5$ cm and the data obtained showed no significant difference from the on axis measurements. Meas-

urements at $r = 1.5$ cm and at multiples of 30 degrees confirmed the cylindrical symmetry of the solenoidal field. The axial field was calibrated against a NMR probe and showed a linear relationship with current over the 0 to 290 A range. The magnetic field maximums at a distance of about 1 meter from the iron shield were about 3 gauss satisfying the <10 gauss specification when the axial field level was 7.3 Tesla.

IV. TESTS AT MIT-BATES

In mid November 1996 a team of five BINP technical staff arrived to assemble, test and provide training to the MIT-Bates staff in the solenoid systems operation. The work went forward rapidly and the first solenoid was cooled down in two weeks. Interfacing of the control system and instrumentation allowed proper control of the unit. MIT-Bates staff made magnetic measurements along the axis at several field levels and determined that the systems magnetic design was achieved. Assembly of the units is demanding particularly at the connection points between the solenoidal and the storage dewar where several joints between the 0.87mm diameter NbTi/Cu superconductor wire are made. These leads run up through the storage dewar and then to the control/quench systems. The second unit was assembled and tested without any problems completing the MIT-Bates acceptance tests required. This acceptance testing was completed within a four week period. Figure 4 shows the arrangement at MIT-Bates during acceptance tests in December 1996.



Fig. 4 Solenoids under test at MIT-Bates. Dec. 1996.

V. CONCLUSIONS

The scientific collaboration between BINP and MIT-Bates has produced a set of superconducting solenoids to provide spin control of a polarized electron beam in the SHR. The collaboration also provides for BINP technical staff to assist MIT-Bates in the commissioning of the "Siberian Snake" when it is installed in the SHR lattice some time in the future. The cooperation of all parties in the project is acknowledged and was important to the success achieved to date. The authors acknowledge the major contribution of V. Seleznev of BINP to the completion of acceptance testing at Novosibirsk and Bates and of S. Ottaway of MIT-Bates during the testing at the Laboratory. See Table 1 for a tabular listing of magnetic specifications.

Table 1. Solenoid Parameters

Integrated Field Strength on axis @290A	.5.764 T-m
Peak Magnetic Field @290A7.27 T
Effective Length 803 mm
Outside axial length f-f 1040 mm
Conductor diameter 0.87 mm
Superconductor fill factor 0.43
Average critical current at 7.3 Tesla310 A
Number of sub section coils in solenoid 5
Number of turns per sub section coil 3170
Total number of turns for solenoid 15,850
Inductance of solenoid 4.5 Henry
Solenoid stored energy @290A 189,000 Joules
ID of coils 124 mm
OD of coils1 60 mm
Build of coils 18 mm
Length of sub coils 160 mm

VI. REFERENCES

- [1] P.M. Ivanov, Yu.M. Shatunov, G.T. Zwart; A Universal Superconductive Spin Rotator for MIT-Bates South Hall Ring., Technical Report No. B/SHR 93-10, MIT-Bates
- [2] R.J. Averill; Technical Specification for Superconducting Solenoids for the MIT-Bates South Hall Ring. October 1, 1993[3] I.Koop, Yu.M. Shatunov, P. Vorobiev,
- [3] Superconducting Solenoid of Spin Rotator for MIT Bates Linear Accelerator Center. Technical Design, BINP, Novosibirsk, 1995
- [4] P. Vorobiev, A. Smirnov & BINP technical staff, Superconducting Solenoid for Spin Rotator, Description