

VACUUM BEAM LOSSES IN THE AXIAL INJECTION SYSTEMS OF THE FLNR HEAVY ION CYCLOTRONS

M.N. El-Shazly, M.V. Khabarov, A.I. Ivanenko, G.G. Gulbekian, FLNR, Joint Institute for Nuclear Research, Dubna, Moscow region, 141980 Russia

Abstract

A simulation program was carried out to calculate the pressure distribution and the beam loss due to the charge exchange cross section in order to optimize the vacuum system parameters of the heavy ion transmission lines. A series of measurements was set up to evaluate the beam loss in the axial injection systems of the FLNR cyclotrons. The pressure measurements were compared with the program.

1 INTRODUCTION

The isochronous cyclotrons U-400M and U-400 [1] have been equipped with ECR ion sources provided with axial injection systems. They were located atop the cyclotron magnets [2,3]. This paper presents a model for calculating the pressure distribution and the beam losses due to the charge exchange with the residual gasses in the axial injection system. The result of the calculations made are compared with those of some pressure measurements. Also Investigated the manner in which the heavy ion beam transmission factor of the ion guide pipe depends on the following parameters: the diameters of its parts, the pumping speed, the gas loading from the ECR ion source, and the gas desorption rate.

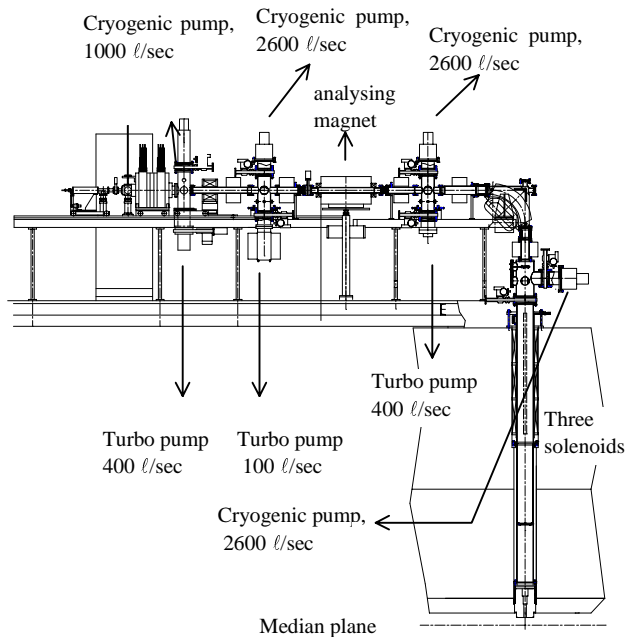

Figure 1. The axial injection system of the U-400 cyclotron

2 VACUUM SYSTEM

Figs. 1 and 2, show the vacuum system of the U-400 and U-400M axial injection systems.

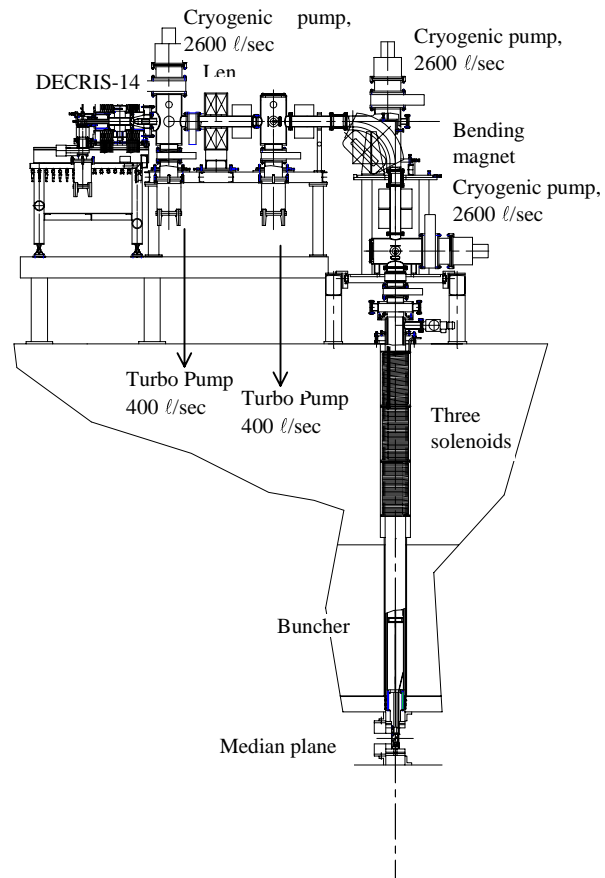

Figure 2: The axial injection system of the U-400M cyclotron

In any vacuum system, the first important gas source is formed by the static or thermal outgassing of weakly adsorbed molecules and diffusion of gasses like H_2 , N_2 , H_2O ,...etc. from the material of ion guide pipe and through the seals.

The systems concerned have specific static outgassing rate ranging from 1.3×10^{-7} to 1.3×10^{-6} Pa ℓ /sec/cm² depending on the pumping time. Choosing the design of the ion guide pipe and the treatment of the material is very important to decrease the static outgassing and, consequently, the pumping time. Responsible for the second important gas source is the dynamic outgassing in the presence of the beam, which results from two causes. The first cause is accounted by the gas loading of N_2 , O_2 , CO_2 , ..., Xe from the ECR ion source, this parameter is expected to range from 3×10^{-3} to 1.6×10^{-2} Pa ℓ /sec. The second cause lies in strongly adsorbed molecules being released because of the lost ion beam striking the ion guide pipe. This means that the dynamic outgassing also depends on the material and the material treatment of the ion guide pipe. The ion guide pipes concerned are made of stainless steel. Used for the seals are VITON 'O' rings. The vacuum systems were created by the JINR in collaboration with Vacuum-Praha (The Czech Republic).

3 PRESSURE DISTRIBUTION

A simulation program was developed estimating the pressure distribution through the ion guide pipe and the ion beam transmission efficiency in relation to the pressure distribution pattern. The program proposed is capable of calculating the pressure distribution through the ion guide pipe comprising any number of parts of various forms and gas molecular conductivity. Within the molecular flow regime the flow of molecules through the ion guide pipe is expressed by the equations

$$Q(x) = -w \frac{dp}{dx} \quad \text{and} \quad \frac{dQ}{dx} = -Aq \quad (1)$$

where

- Q (Pa ℓ/sec) gas flow.
- A (cm²/m) specific surface area.
- q (Pa ℓ/sec/cm²) specific static outgassing rate.
- p (Pa) pressure.
- w (mℓ/sec) specific molecular conductance.

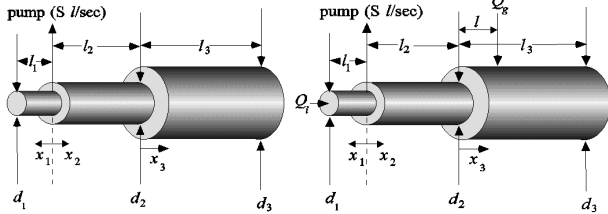

Figure 3.

Figure 4.

To explain the mathematical algorithm of the program let us divide our vacuum chamber into three parts each part being of length l_i , and diameter d_i . The specific static outgassing in the i -part will be q_i , $i=1,2,3$ (see Fig. 3). Granted that there is only one pump and no beam, just only the static outgassing, the pressure distribution along the coordinates x_1 , x_2 , and x_3 is defined by the equations [5].

$$P_q(x_1) = \frac{q_1 \pi d_1 l_1}{S} + \frac{q_2 \pi d_2 l_2}{S} + \frac{q_3 \pi d_3 l_3}{S} + \frac{q_1 \pi d_1 x_1}{12 d_1^3} \left(l_1 - \frac{x_1}{2} \right) \quad (2 A)$$

$$P_q(x_2) = \frac{q_1 \pi d_1 l_1}{S} + \frac{q_2 \pi d_2 l_2}{S} + \frac{q_3 \pi d_3 l_3}{S} + \frac{q_3 \pi d_3 l_3 x_2}{12 d_3^3} + \frac{q_2 \pi d_2 x_2}{12 d_2^3} \left(l_2 - \frac{x_2}{2} \right) \quad (2 B)$$

$$P_q(x_3) = \frac{q_1 \pi d_1 l_1}{S} + \frac{q_2 \pi d_2 l_2}{S} + \frac{q_3 \pi d_3 l_3}{S} + \frac{q_3 \pi d_3 l_3 x_3}{12 d_3^3} + \frac{q_2 \pi d_2 l_2^2}{24 d_2^3} + \frac{q_3 \pi d_3 x_3}{12 d_3^3} \left(l_3 - \frac{x_3}{2} \right) \quad (2 C)$$

where

- S (ℓ/sec) is the pump speed

Not only there is static outgassing but also dynamic outgassing in the ion guide pipe, the latter being formed by two sources. The gas loading from the ECR ion source is responsible for the first gas source and stimulated desorped gases caused by the lost ions makes up the second source. The gas desorption rate due to the lost beam was calculated according to the next equation [4].

$$Q_g = 1000 \frac{I}{Z} \gamma_i K T \quad (3)$$

where

- Q_g (Pa ℓ/sec) the gas desorption rate due to lost beam

- I (A) the lost beam intensity
- Z (coulomb) the average charge state of the lost ions
- γ_i (mol./ion) the gas desorption yield
- K (Joul/°K) Boltzmann constant
- T (°K) gas temperature

The gas desorption yields from the ion guide pipe at room temperature are considered to lie between 2 and 3 mol/ion. Granted that the system configured as shown in Fig. 4 is only of one pump and static outgassing-free, the gas loading from an the ion source being Q_i and the gas desorption due to beam losses Q_g , then the pressure distribution through the vacuum chamber concerned will be as follows:

$$P_Q(x_1) = \frac{Q_g}{S} + Q_i \left(\frac{x_1}{12 d_1^3} + \frac{1}{S} \right) \quad (4 A)$$

$$P_Q(x_2) = \frac{Q_i}{S} + Q_g \left(\frac{x_2}{12 d_2^3} + \frac{1}{S} \right) \quad (4 B)$$

$$P_Q(x_3) = \frac{Q_i}{S} + Q_g \left(\frac{l_2}{12 d_2^3} + \frac{1}{S} + \frac{x_3}{12 d_3^3} \right) \quad \text{if } x < l \quad (4 C)$$

$$P_Q(x_3) = \frac{Q_i}{S} + Q_g \left(\frac{l_2}{12 d_2^3} + \frac{1}{S} + \frac{l}{12 d_3^3} \right) \quad \text{if } x > l \quad (4 C')$$

If there is in addition static outgassing the pressure distribution is founded by combining equations (2) and (4).

$$P_j(x_i) = P_q(x_i) + P_Q(x_i) \quad (5)$$

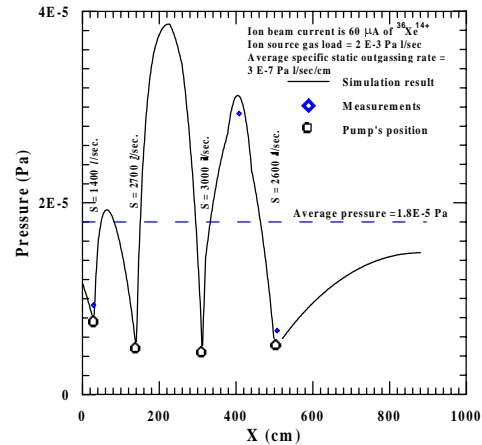

Figure 5: The pressure distribution in the ion guide pipe of the axial injection system of the U-400 cyclotron.

To return to the axial injection systems of the U-400 and U-400M cyclotrons, as shown in Figs. 1 and 2 there are more than one pump located at four sites along the length of each ion guide pipe. The pressure distributions due to these pumps were calculated according to the next equation:

$$\frac{1}{P(x_i)} = \sum_{j=1,4} \frac{1}{P_j(x_i)} \quad (6)$$

The pressure was measured at three points in each system at various beam current intensities and varying the number of pumps in operation. The results of the measurements were compared with those of the simulations. The results of the simulation and measurements are shown in Figs. 5 and 6.

4 TRANSMISSION FACTOR

The transmission factor depends on the pressure distribution and the charge exchange cross section between the beam ion

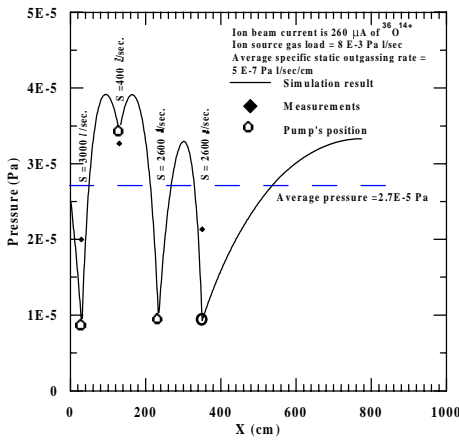

Figure 6: The pressure distribution in the ion guide pipe of the axial injection system of the U-400M cyclotron.

considered as a projectile and residual gas considered as a target. The pressure distribution can be founded as indicated above. The ECR ion source injection voltage lies 12-25 kV range depending on the ion beam charge-to-mass ratio. In this energy range, the single-electron capture cross section is much higher than that of single-electron loss cross section and of multi-electron capture cross section, it depends on the first ionization potential of the target (residual gas), varies in direct proportion to the ion charge, and is independent of energy. An approximate scaling rule can be used for this energy range [6].

$$\sigma_{z,z-1} = 1.43 \times 10^{12} z^{1.17} R^{-2.76} \quad (7)$$

where

- $\sigma_{z,z-1} (\text{cm}^2)$ the electron capture cross section
- $z(\text{coulomb})$ the ion (projectile) charge
- $R(\text{eV})$ the first ionization potential of the target (residual gas).

In this case, the transmission factor for any ion in our ion guide pipe can be obtained easily using the next formula:

$$\tau = \frac{100}{\exp\left(2.69 \times 10^{16} \sigma_{z,z-1} \int_0^L P(x_i) dx_i\right)} \quad (8)$$

where

- τ transmission factor
- $\sigma_{z,z-1} (\text{cm}^2)$ the single electron capture cross section
- $P (\text{Pa})$ pressure

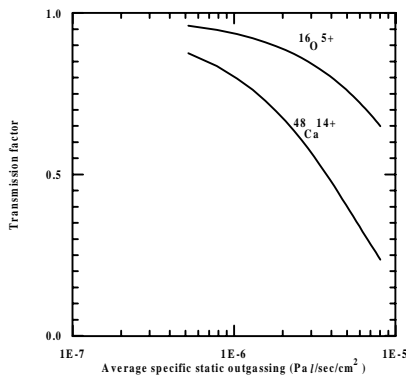

Figure 7: The specific static outgassing effect on the transmission factor through the axial injection system of the U-400M cyclotron.

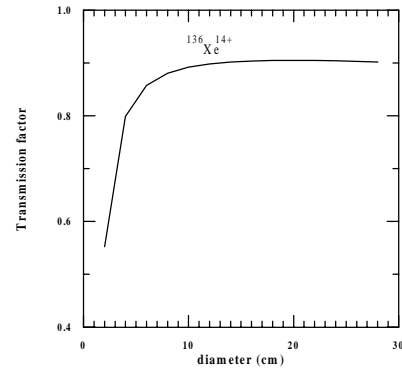

Figure 8: The transmission factor due to the variation of the diameter of the ion guide pipe in the axial hole of the U400 cyclotron magnet.

The transmission factor is seen to depend on the average pressure only. On this basis, the relationships between the transmission factors and the vacuum system's parameters were investigated under the conditions that are written in Figs. 5 and 6. For example, in the axial injection system of the U-400M cyclotron, where $^{16}\text{O}^{5+}$ and $^{48}\text{Ca}^{14+}$ 260 μA beams were being considered and the gas loading from the ion source was being taken to be about 8×10^{-3} Pa ℓ/sec , the relation between the transmission factor and the specific static outgassing rate is presented in Fig. 7. In the axial injection system of the U-400 cyclotron, the diameter of the ion guide pipe in the axial hole of the magnet first was varied from 2cm to 20cm. The diameter dependence of the transmission factor is shown in Fig. 8.

5 CONCLUSION

The investigation of various parameters affecting the pressure distribution and the transmission factor of the axial injection systems of the U-400 and U-400M cyclotrons shows that:

- The most important parameter is the static outgassing.
- The second cryopump of the axial injection system of the U-400M has an insignificant effect on the average pressure and, consequently, on the beam intensities.
- The pumping speed is an important parameter from the stand point of reaching the required level of the static outgassing as quickly as possible.
- The transmission factor increases insignificantly with the diameters of the ion guide pipe for the values of the diameters greater than those of the existing configuration.
- The gas load from the ECR ion source has not great effect on the transmission factor because of the two pumps that are installed after the ECR ion source.
- It is possible to increase the ion beam current up to 1 mA and the beam losses will not be much higher.

The simulation program is useful to optimize the vacuum parameters of the transmission lines and linear accelerator after choosing the cross section formula in their range of energies.

REFERENCES

- [1] Gulbekian G. et al., 13th Inter. Conf. on Cyclotrons and Their Application, Vancouver, 1992, p.11
- [2] Efremov A. et al., Rev. Sci. Inst., V. 65 (4), 1994, p.1084.
- [3] Gulbekian G. et. al., Axial injection
- [4] Gröbner O, CAS, CERN, V. 2, 85-19, 27 Nov. 1985, p489.
- [5] Kalinin Yu Zh. et. al., Vacuum, V. 46, No. 7, 1995, p.717.
- [6] Müller A. et al., Inst. Phys. Conf. , No. 38, 1978, Chapter 4.