

JEFFERSON LAB IR FEL CRYOMODULE MODIFICATIONS AND TEST RESULTS

M. Wiseman, J. Benesch, M. Drury, J. Fisher, D. Machie, J. Mammosser, L. Phillips, and J. Preble, Thomas Jefferson National Accelerator Facility, 12000 Jefferson Avenue, Newport News, Virginia 23606 U.S.A.

Abstract

The Infrared Free Electron Laser being constructed at the Thomas Jefferson National Accelerator Facility will require a 42 MeV, 5 mA electron accelerator. The accelerator design requires a 10 MeV injector and a two pass 32 MeV linac, one pass for acceleration and one pass for energy recovery. In order to minimize the cost of the linac, standard CEBAF 1497 MHz Superconducting Radio Frequency cavities and cryomodules are being used with minimal changes. Two SRF cavities, housed in a quarter cryomodule, operate at a nominal 10 MV/m to provide the injector energy. The linac is composed of one cryomodule, housing eight SRF cavities operating at an average gradient of 8 MV/m. The modifications to the cryomodule are being made to handle the higher beam current, to improve RF control, and to increase machine reliability. The modifications to the higher order mode (HOM) loads, cavity tuners, cavity beam line, warm and cold RF windows, and cryogenic shield are described. Test results from the injector quarter cryomodule are also presented.

1 INTRODUCTION

The Infrared Free Electron Laser currently being constructed at the Thomas Jefferson National Accelerator Facility (Jefferson Lab) is to serve as a research tool for both the DOD and industry [1]. This facility will deliver up to 1 kW of 1 to 3 micron IR light to one of six user laboratories. A photocathode electron gun produces a 500 keV, 5 mA beam which is boosted to 10 MeV by a Continuous Electron Beam Accelerator Facility style quarter cryomodule containing two 1497 MHz Superconducting Radio Frequency cavities before injection into the main accelerator ring. The accelerator linac boosts the electron energy to 42 MeV via a cryomodule containing eight SRF cavities. The beam then passes through the IR wiggler magnet which generates the IR light. The electron beam is then recirculated back through the cryomodule, where the electron energy is recovered before being dumped at 10 MeV. The photocathode electron gun and the quarter cryomodule for the injector have already been built and are currently being tested at Jefferson Lab.

The higher beam current, 5 mA vs. CEBAF's 200 μ A, required that certain modifications be done to the standard CEBAF cryomodule. The design changes for the cryomodule are compatible with the requirements for a possible upgrade of the 42 MeV IR FEL accelerator to a

200 MeV UV FEL accelerator. Other changes have also been incorporated to improve machine reliability and operability.

2 SRF REQUIREMENTS AND TEST RESULTS

The FEL requirements for the SRF cavities are given in Table 1. The energy requirements chosen were based on the average CEBAF cavity results and RF control requirements for the FEL. Changes have been made to several of the cavity peripherals with no changes to the CEBAF 1497 MHz SRF cavities themselves. New higher order mode assemblies have been developed to route the HOM energy to the cryomodule's 50 K thermal shield.

TABLE 1. IR FEL SRF Cavity Requirements.

	Injector Quarter Cryomodule	linac Cryomodule
Avg. Gradient (MV/m)	10	8
Q_0 at Avg. Gradient	3×10^9	3×10^9
Q_{ext} (+/- 20%)	1.3×10^{11}	5.2×10^{11}
Q_{ipc}	1.3 to 4.4×10^6	3.3 to 6.6×10^6
HOM Power/Load	3.8 W	7.5 W
RF Power/Cavity	30 kW	2.5 kW

The cavities chosen for the injector quarter cryomodule have undergone extensive testing and special processing including heat treatment before being selected for use in the FEL [2]. The cavity pair has been tested four times, twice in the vertical test area and twice since being assembled into the quarter cryomodule. Cavity IA 362 exceeds the design requirements while cavity IA 328 is limited by Q_0 degradation to 9 MV/m. The required injection energy of 10 MeV can be met by running the cavities at 11 and 9 MV/m respectively.

3 HOM LOADS, HEAT SINKS, AND THERMAL SHIELD

The design changes for the HOM loads, heat sinks and thermal shields meet the requirements of a possible upgrade to a 200 MeV UV FEL accelerator. For the UV linac, the higher order mode power per load is presently 15 W, or 240 W per cryomodule. Design changes were made to the HOM assemblies and cryostat in order to heat sink this power to the 50 K thermal shield where it is more efficiently dissipated (FIGURE 1). Each heat sink and the thermal shield was designed to dissipate 30 W of power per load.

Each HOM load assembly now consists of a ceramic load, a copper base and heat sink rod, and a stainless steel flange with a pant leg thermal stand off to limit the total static and dynamic heat load to 2 K to less than 1 W. For

the quarter cryomodule, ceramic loads [3] were used and brazed to the copper base. This assembly required expensive machining of the copper base and proved difficult to produce a reliable ceramic to copper braze joint. In addition, the glassy carbon ceramic originally used in CEBAF because of its 2 K RF absorption characteristics, is difficult to produce to the required specifications. For these reasons, the design for the cryomodule has been changed. The ceramic load for the cryomodule will be a silicon carbide ceramic which has adequate RF absorption for the FEL at temperatures above 40 K. The ceramic to copper base has also been changed to a bolted joint with an indium gasket. This design has proven to be more reliable and much more cost effective to produce (FIGURE 2).

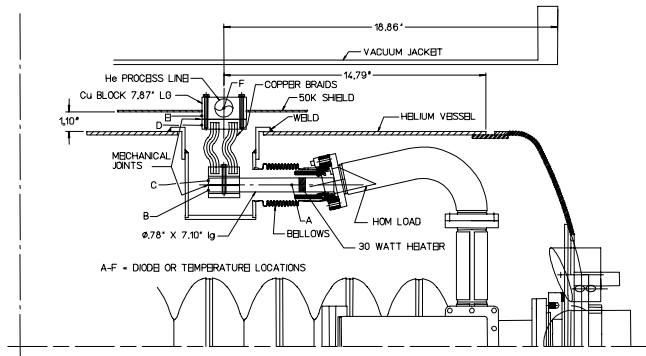

FIGURE 1. FEL cryomodule cross section showing modifications and test instrumentation.

The rest of the heat sink design consists of a copper braid assembly which is bolted to both the HOM assembly heat sink rod and to the 50 K thermal shield. Copper braids were used to provide flexibility in the design to allow for assembly, mechanical tuning of the SRF cavities, cooldown mechanical contractions, and to mitigate microphonic coupling to the cavities from the thermal shield. The 50 K thermal shield was also modified in order to route the helium process lines as close to the HOM loads as possible and to provide adequate thermal area for convective cooling of the localized HOM heat loads. The process line was also enlarged to accommodate higher helium flow rates and to reduce flow induced vibration effects.

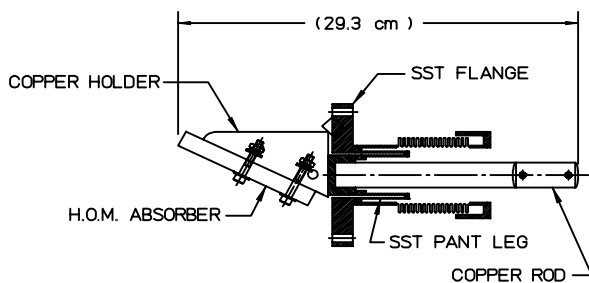

FIGURE 2. FEL HOM load and heat sink design.

Provisions for testing the heat sink design were made in the quarter cryomodule before beginning cryomodule production. Thirty watt strip heaters were mounted on the copper heat sink rods near the HOM loads and diodes were mounted along the heat sinks as shown in FIGURE 1. Test results during the quarter commissioning showed good agreement with the design values. The heat strap connection from the HOM loads to the shield for the production cryomodule has been modified slightly to make assembly of the cryomodules easier with only a small reduction in thermal performance. Microphonic effects on the SRF cavities from the heat sink design and increased shield flow were also tested with no measurable effects.

4 MAGNETOSTRICTIVE TUNER

The FEL will use energy recovery to reduce the RF power needed, thereby improving the overall efficiency of the machine, and to reduce the beam power deposited in the dumps. To ease the demands on the RF controls, a magnetostrictive tuner has been added to the existing CEBAF mechanical tuner. The magnetostrictive tuner is designed to deliver +/- 250 Hz of mechanical tuning on a 1 second time frame and will be used during machine operations. The CEBAF mechanical tuner delivers +/- 200 kHz of tuning, but is slow and is only used during machine setup. The magnetostrictive tuner is a 200 alloy nickel tube surrounded by a 2.5 kgauss superconducting solenoid. An iron sheath is used to concentrate the magnetic fields. Two layers of Mu metal provide magnetic shielding for the cavities prior to cooldown and one layer of Nb is used to provide shielding at 2 K during operation. The design and early test results are better described elsewhere [4].

5 QUARTER CRYOMODULE WARM RF WINDOWS AND VACUUM RF WAVEGUIDE

In the injector quarter cryomodule, 30 kW of RF power is used to accelerate the 5 mA beam in each cavity. This is ten times the power used in the CEBAF and FEL linacs. In order to handle this power, the polyethylene window used in the linacs has been replaced with a ceramic window and additional heat intercepts have been added to the vacuum RF waveguide to prevent thermal runaway and improve vacuum stability in the waveguide. The warm ceramic window is the same ceramic and essentially the same design used for the cold RF windows in CEBAF. The window is vacuum brazed into a 0.25 cm thick nickel eyelet and then electron beam welded into a stainless steel flange. The flange is copper plated to reduce RF heating around the window. A Helicoflex seal is used to complete the vacuum/RF seal with the existing waveguide. The windows will be qualified with 50 kW of RF power prior to use on the quarter cryomodule.

The thermal effects of the additional RF power in the CEBAF RF waveguide were studied using a finite difference program [5]. These results indicated a possible

thermal runaway condition in the existing CEBAF waveguide. Two additional thermal intercepts were added and their location optimized to minimize the static and dynamic heat loads to both the thermal shield and the 2 K bath (FIGURE 3). Additionally, active cooling will be used at the room temperature end of the waveguide to both stabilize the waveguide, and to prevent undue heating of the warm RF window.

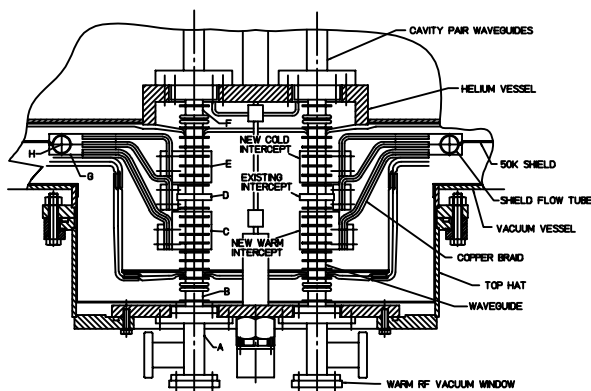

FIGURE 3. FEL quarter cryomodule showing waveguide modifications.

The FEL quarter cryomodule has recently undergone two different cold tests. The static thermal profile in the waveguide agrees quite nicely with the predicted results. The warm window and waveguide have been tested off resonance for extended periods with up to 15 kW of forward power and for short periods with up to 19 kW of RF power. The thermal profiles in the waveguide are in general agreement with those predicted (FIGURE 4) with no thermal runaway. There has been some difficulty in producing reliable warm ceramic windows. Several different materials and assembly techniques have been tried. Several failures have occurred during testing and more work is required before a window is available that will be considered ready for machine operation.

6 CRYOMODULE BEAM LINE

The FEL's 5 mA beam and recirculation for energy recovery require two changes in the cryomodule stainless and Nb beam line. First, in order to reduce the beam impedance effects and RF induced heating to 2 K, RF shielding has been employed on all cold stainless steel bellows in both the quarter and full cryomodule. RF shielding was also employed on the 2.8 cm gate valves on the quarter cryomodule and on the beam line pump drops for the linac cryomodule. The second change was made in order to increase beam transmission through the cryomodule during energy recovery. The Nb spool pieces between the cavities were increased from 3.5 cm to 4.8 cm. The spool piece diameter was not increased further due to RF crosstalk concerns between the cavities. The stainless steel beam pipe into and out of the cryomodules were similarly increased. An economical 5 cm RF shielded gate valve was not readily available to replace

the eight gate valves inside the cryomodule, so the three sections of stainless steel beam pipe between the cavity pairs were increased to 7 cm ID and unshielded gate valves were used.

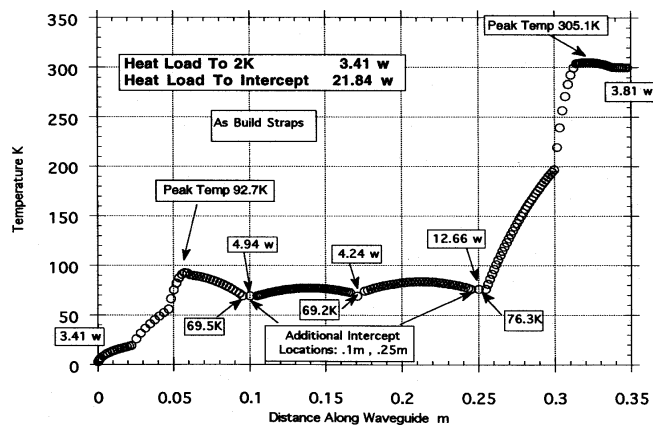

FIGURE 4. Predicted temperature profile in the vacuum waveguide.

7 SUMMARY

The prototypical quarter cryomodule has been built for the FEL injector with a cavity pair meeting the design goal for gradient and Q_0 . The majority of changes in the CEBAF cryomodules necessitated for the Jefferson Lab FEL project have been incorporated into, and tested in a quarter cryomodule. The remaining changes are presently being assembled into the first linac cryomodule, which is scheduled for completion this summer. The changes tested so far in the quarter cryomodule have mostly met their design goals, and a few minor changes are being incorporated in the cryomodule as a result of lessons learned. Testing and development of reliable warm RF windows is ongoing.

8 ACKNOWLEDGMENTS

This work was supported by the U.S. DOE under contract number DE-AC05-84ER40150.

REFERENCES

- [1] Benson, S., "Overview of the Jefferson Lab IR FEL Program", JLAB-TN# 96-064.
- [2] Kneisel, P., "Qualification of "Spare" Cavities for FEL Use", JLAB-TN-97-003.
- [3] Campisi, I. et al., "Higher-Order -mode Damping and Microwave Absorption at 2K", CEBAF-PR-92-010, March 1992.
- [4] Benesch, J. F., and Wiseman, M., "Tests of a Prototype Magnetostrictive Tuner for Superconducting Cavities" to be published in *IEEE Transactions in Applied Superconductivity*, 1997, as part of Proceedings.
- [5] Wiseman, M., Machie, D., and Schultheiss, T. (Northrop/Grumman), "RF Vacuum Waveguide Design for the Injector Test Stand", CEBAF-TN#-95-054.