

Cyclotrons from protons to Carbon for Hadron Therapy

Y. Jongen
PAC 2013

Pasadena, October 3^d 2013



**Hadron therapy
started with
cyclotrons...**



The early days

- The possible use of the Bragg peak of high energy ions in the radiotherapy of cancer was suggested by Bob Wilson in 1946
- But it took more than a decade to see real clinical use of particle beam therapy in cancer treatment
- The first patient treatments took place in the late 1950's and early 1960's using synchrocyclotrons at LBNL in Berkeley, at Uppsala University in Sweden and at Harvard Cyclotron Laboratory (HCL)
- HCL had a specially important role in developing present day proton therapy techniques, while Berkeley developed the early steps of heavier ions therapy

The 184" Berkeley Synchrocyclotron

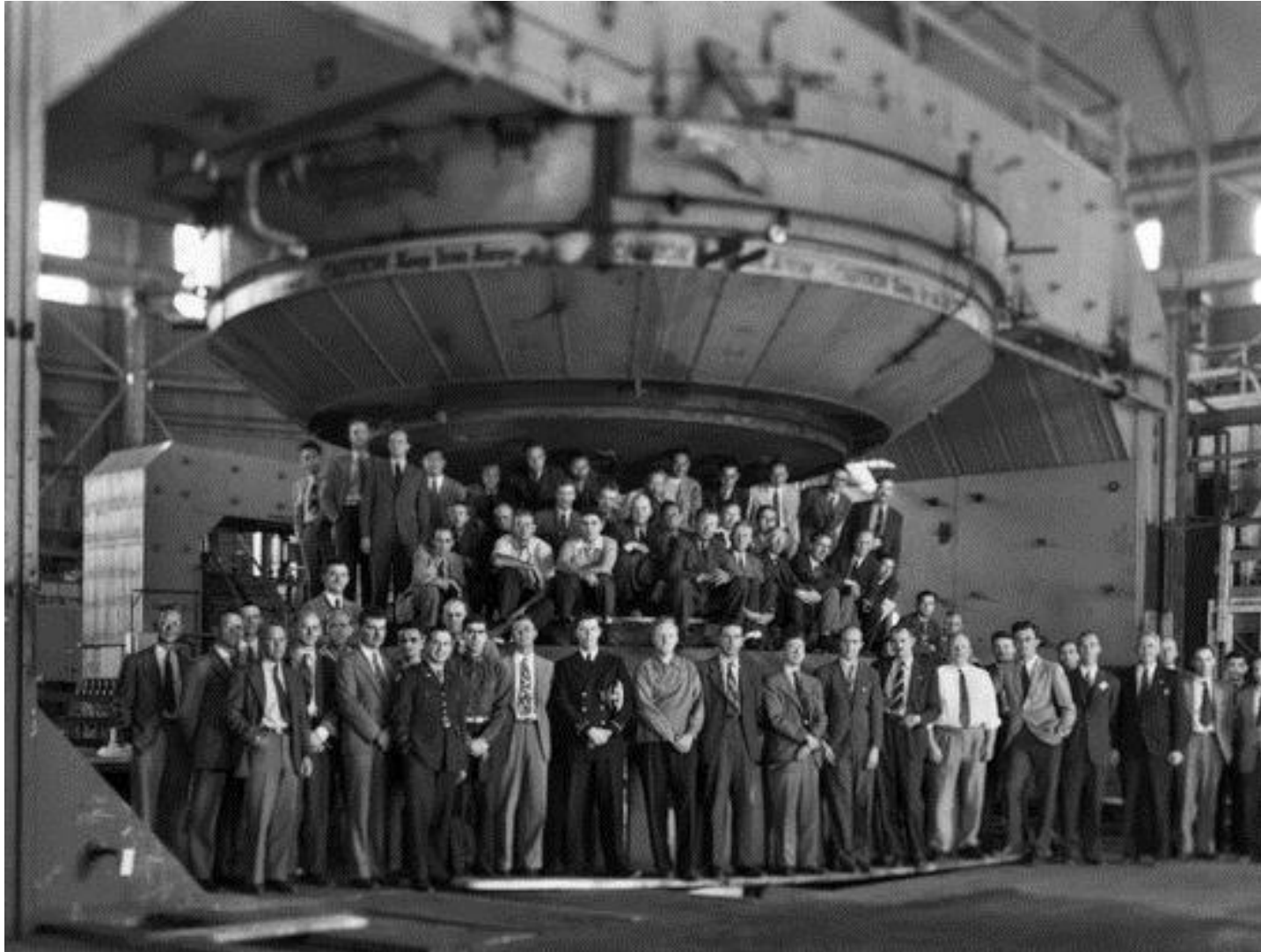

The 185 MeV Synchrocyclotron in Uppsala

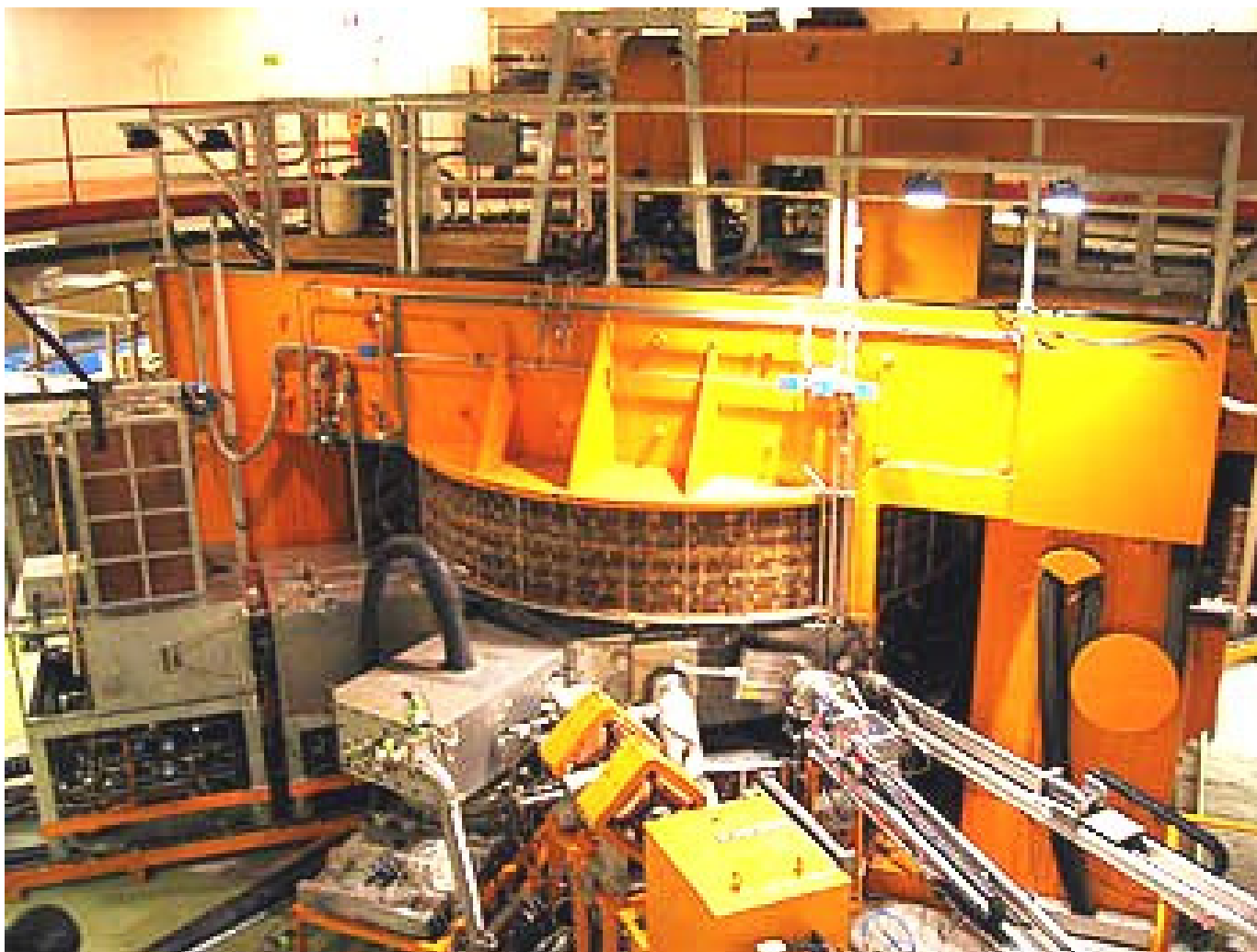

The Harvard Synchrocyclotron

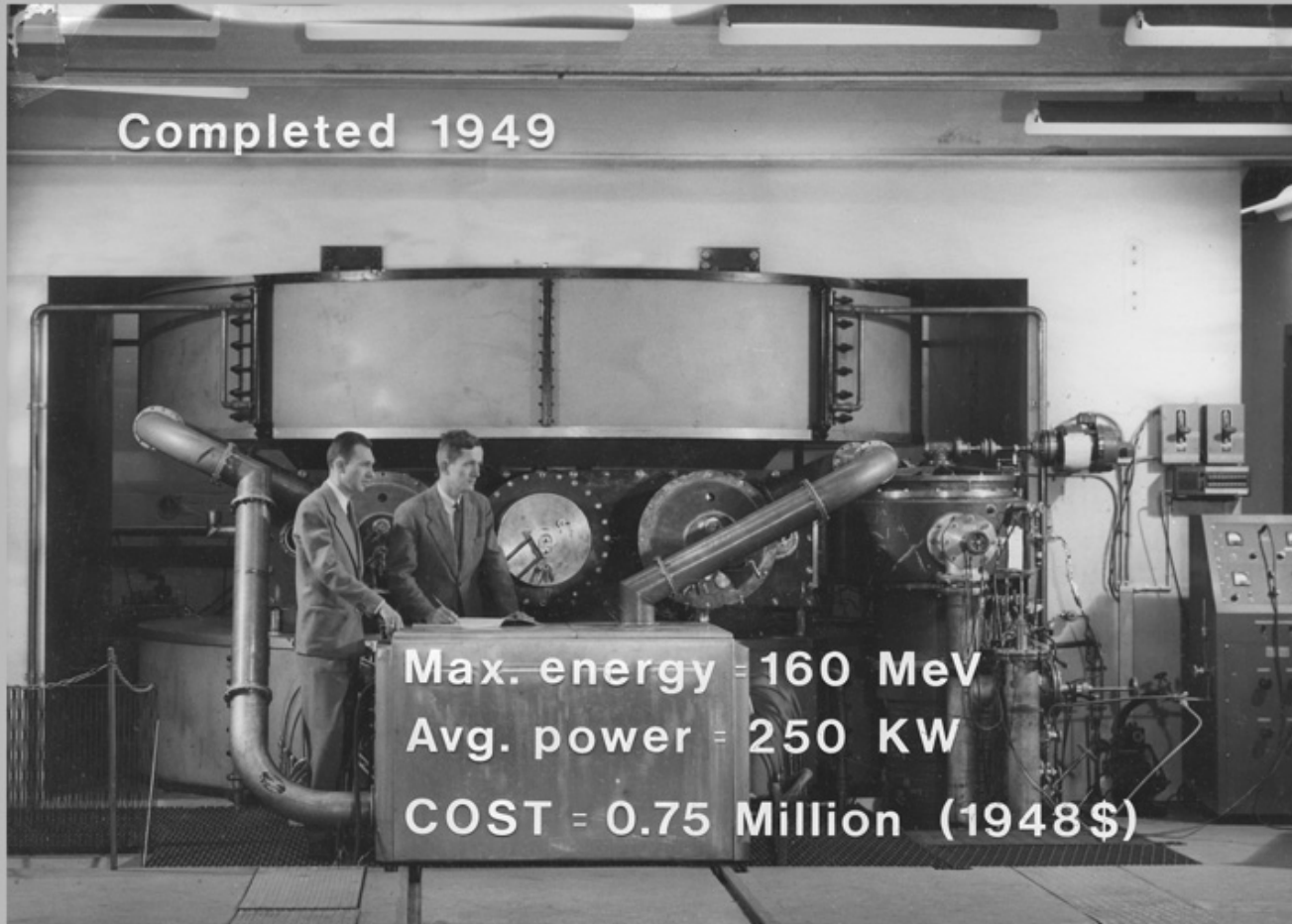

(L) Dr. Lee Davenport (R) Dr. Norman Ramsey
June 10 1949

Andy Koehler and Jason Burns in the MCR (1989)

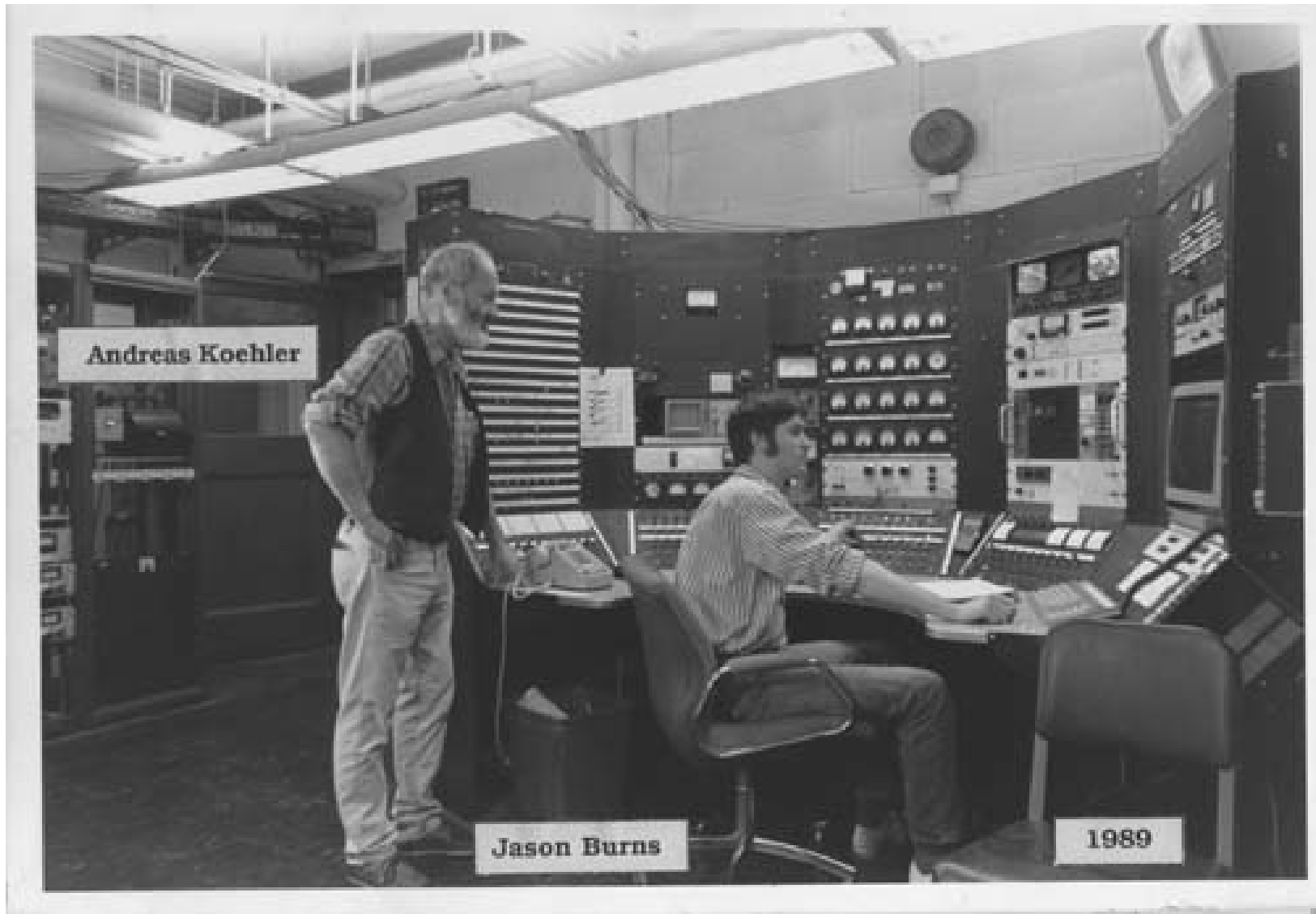

The next step: Hospital based facilities

- ❑ The successful experience of HCL indicated clearly that it would be better to have the proton therapy facility within the hospital, rather than in an ex-physics laboratory
- ❑ In 1983, the different laboratories developing PT got together and formed the Proton Therapy Cooperative Group (PTCoG) to develop hospital based PT facilities
- ❑ The first achievement of PTCoG was to develop a common set of specifications for an hospital based PT facility
- ❑ Over the years, PTCoG has evolved from an informal group regrouping 35 PT specialists twice a year to a much larger (but still quite informal) group bringing more than 600 people together for an annual conference
- ❑ The 53 PTCoG meeting will organized in Shanghai (China) on June 8-14 2014 (<http://www.ptcog53.org/en/index.asp>)

Loma Linda

- While most of the early development of proton therapy was made in Harvard, the group led by Pr. James (Jim) Slater at Loma Linda University Medical Center (LLUMC) was the first to be able to raise the funds needed to build a hospital based PT facility
- The development of the accelerator was subcontracted by LLUMC to a group of experienced accelerator physicists at Fermilab.
- The accelerator technology selected was a synchrotron and for a long time the synchrotron would be considered the technology of choice for PT

Massachusetts General Hospital (MGH)

- MGH, who was leading the PT development at HCL got in 1992 from NCI and private donors the budget needed to build an in hospital PT facility. An international tender was launched
- After a first selection, 3 groups remained in the race:
 - Varian, allied with Maxwell-Brobeck proposed a synchrotron based system
 - Siemens proposed 2 solutions. One based on a synchrotron, the other based on a superconducting isochronous
 - IBA, allied with General Atomics proposed a solution based on a resistive isochronous cyclotron of 230 MeV
- Eventually, the IBA system was selected by MGH, and the contract was signed in 1994 with the goal to treat a first patient in 1998

IBA 230 MeV resistive isochronous cyclotron



IBA Proton Therapy System

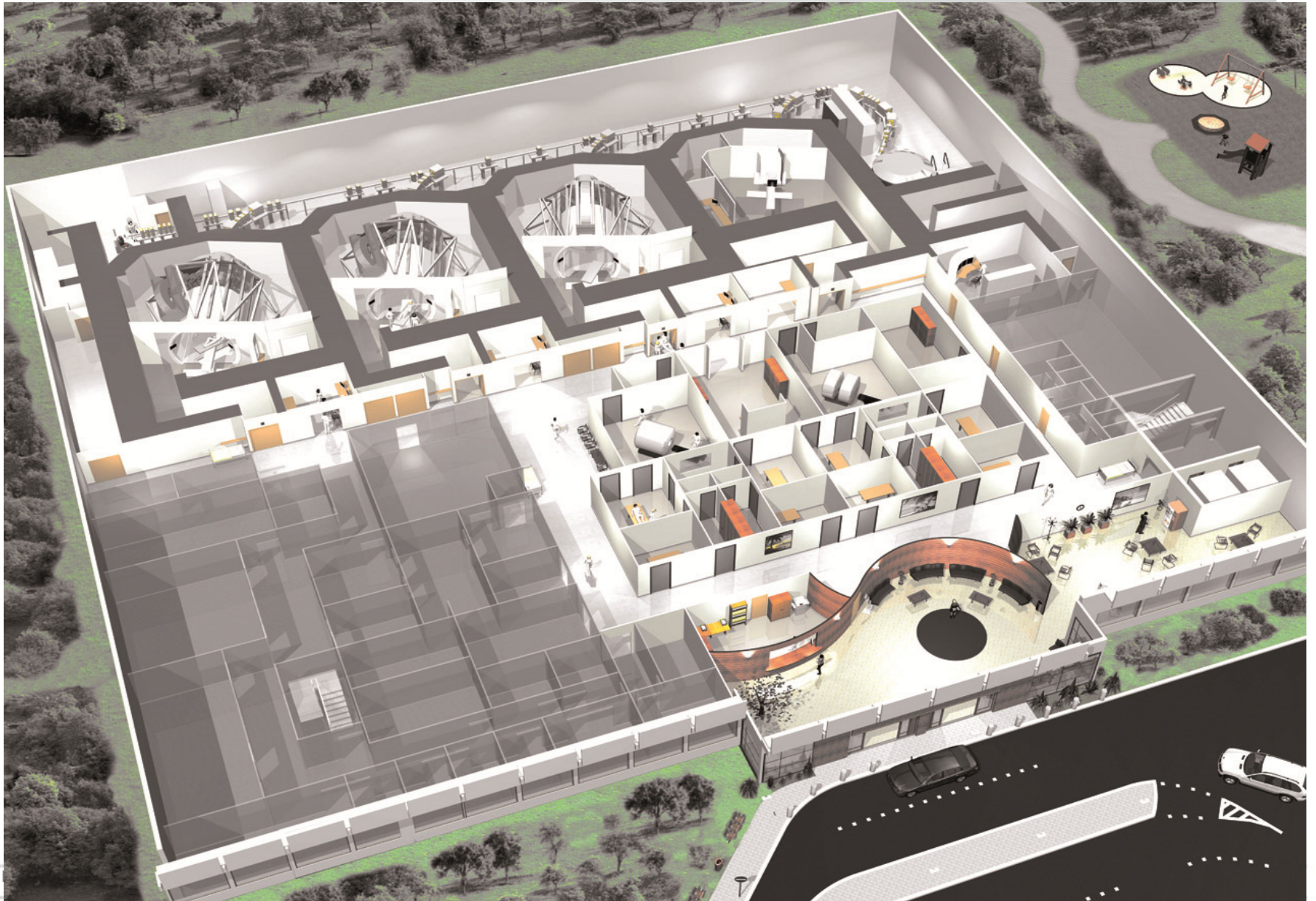

Isocentric gantry treatment room



IBA – Patients treated

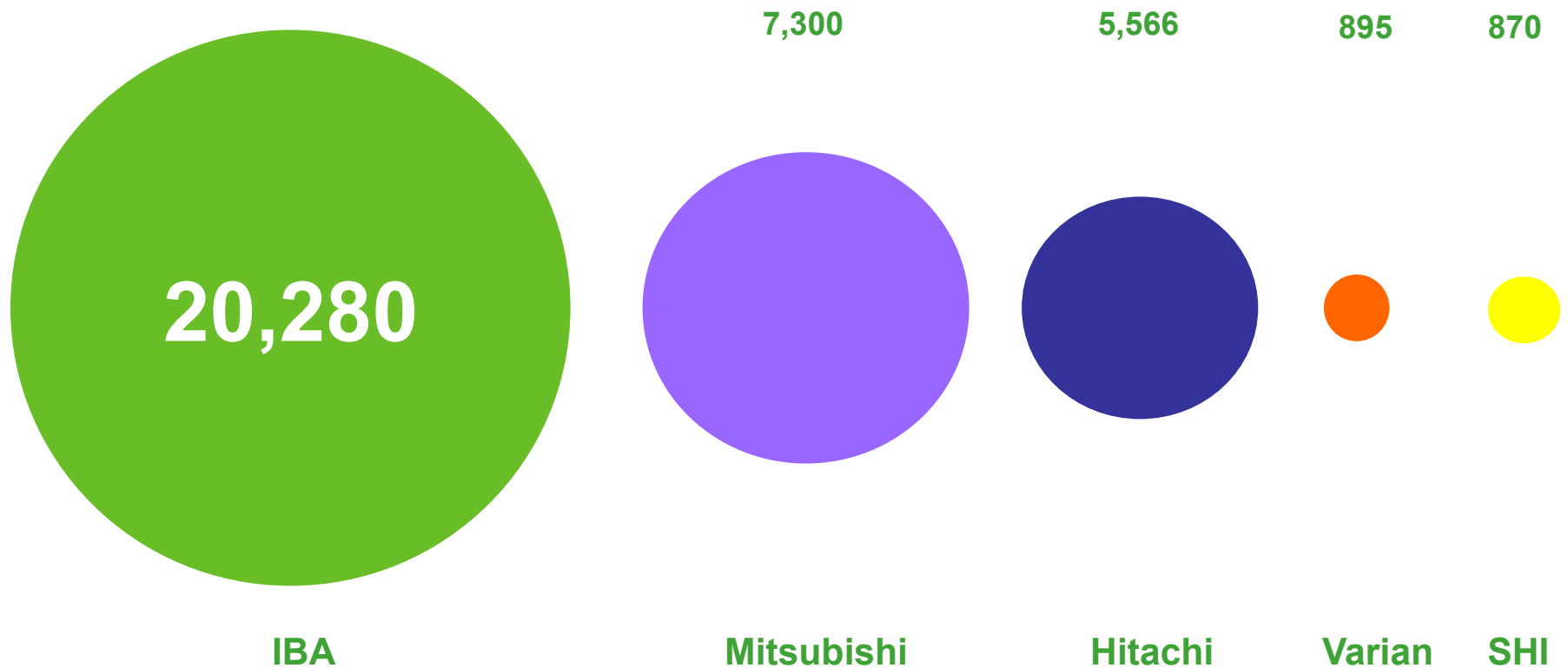

Superconducting cyclotrons...



ACCEL-Varian

- Around 1995, ACCEL decided to return to the field of proton therapy, and asked Henry Blosser to design for them a high extraction efficiency, 250 MeV SC isochronous cyclotron
- The prototype of the new ACCEL cyclotron was sold to PSI for their new PT facility
- Then in 2002, ACCEL was selected to deliver a 5 treatment rooms PT facility to the clinic of Dr. Rinecker in Munich
- Like for IBA, the development and installation of the cyclotron, beam lines and isocentric gantries was more or less on schedule, but major difficulties were encountered for the development of the treatment software
- Eventually, in 2007, ACCEL was acquired by Varian, the leader in classical (photons) radiotherapy equipment
- The first patient was treated at the Rinecker PTC in 2009

ACCEL-Varian superconducting cyclotron

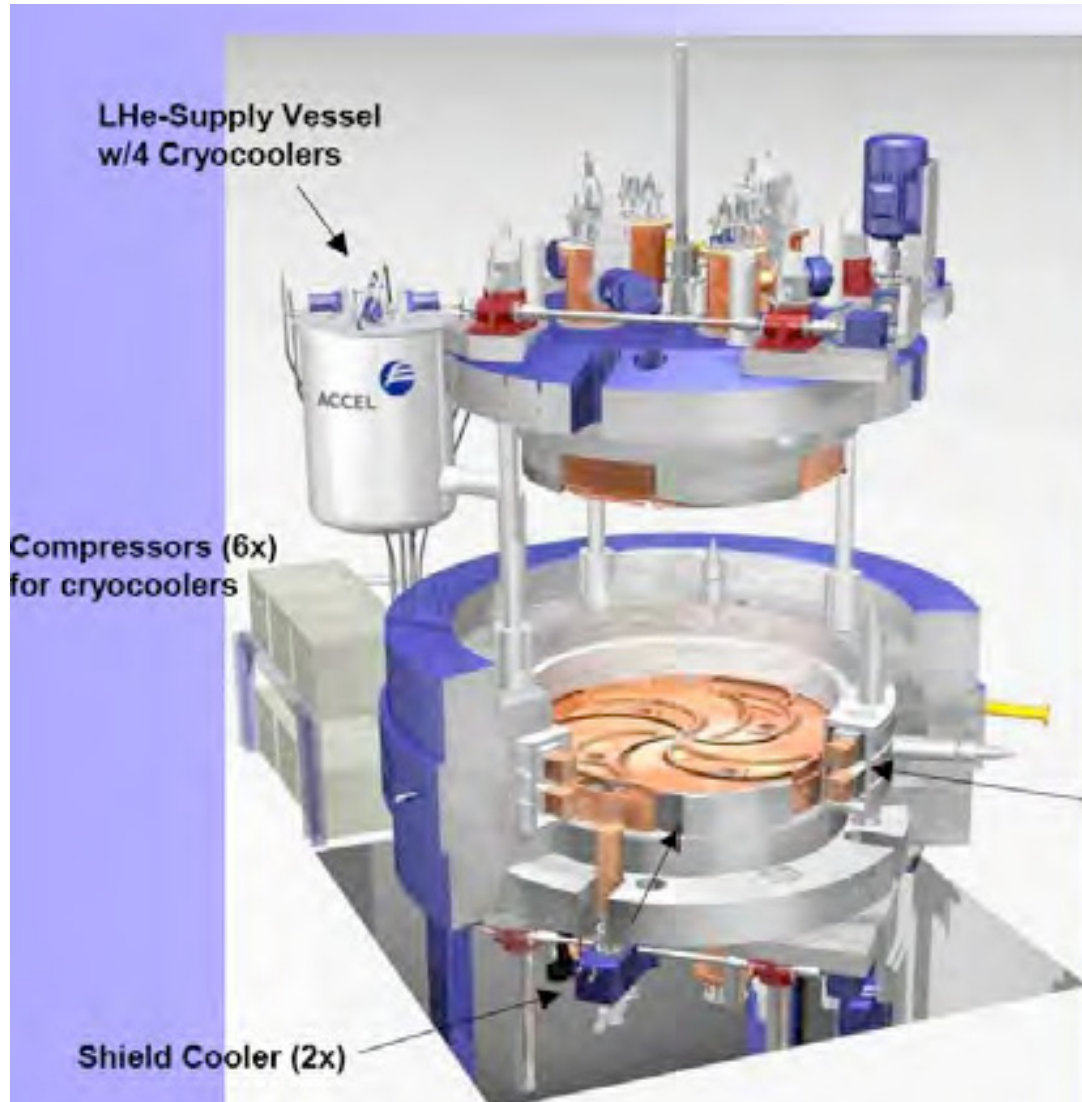

**250 MeV
Superconducting
Proton Cyclotron**

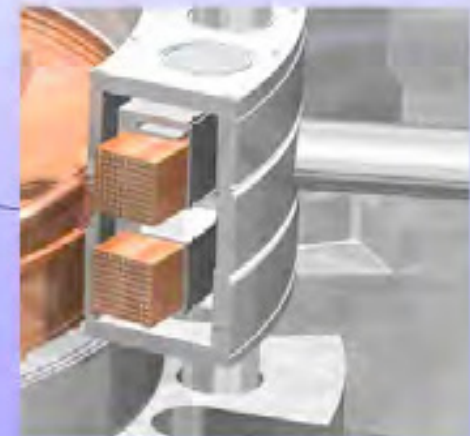

Superconducting Coil

**Proton therapy: from
isochronous cyclotrons
back to
synchrocyclotrons???**



Axial focusing in a spiral sector cyclotron

$$v_z^2 = N + (1 + 2 \cdot \text{tg}^2 \zeta) \cdot F$$

$$F = \frac{\langle \mathbf{B}^2 \rangle - \langle \mathbf{B} \rangle^2}{\langle \mathbf{B} \rangle^2}$$

In current isochronous cyclotrons, the difference in magnetic field between the hills and the valleys is obtained by varying the gap. This difference is, at most, 2.1 T

Increasing $\langle B \rangle$ decreases the flutter

$\langle B \rangle$	B_h	B_v	F
2.1	3.1	1.1	22.7%
3.5	4.5	2.5	8.2%
7	8	6	2.0%

- If you want to do a very small cyclotron, you want a very high average magnetic field
- With a very high average magnetic field, the flutter becomes too low, and going back to weak focusing (the Synchrocyclotron) is the only possible solution

The compact PT system of Still River Systems

- Around 2004, the Still River Systems company was formed by medical physicists who had shared the PT experience of HCL and MGH: Ken Gall, Miles Wagner and Skip Rosenthal.
- Their goal was to design and build a one room, very compact PT system based on a very high field (9T) synchrocyclotron mounted on a gantry and rotating around the patient
- The original design of the cyclotron was made for them by Tim Antaya from MIT, but the further development of the cyclotron was made by SRS, independently from MIT

Ken Gall and his 9T S2C2



IBA new S2C2

- IBA has also completed the design and started the construction of a small size, low cost S2C2
- Unlike SRS system, IBA is designed for spot scanning, and will not be mounted in a gantry, but will be directly coupled to a compact gantry including an ESS. The maximum energy is therefore limited to 230 MeV
- The field at the center is 5.6T, and the peak field 7 T in the coils. This allows us to use less costly Nb-Ti conductor. The coils are dry and conduction cooled by 4 cryogenerators
- The RF is modulated at 1000 Hz.
- A patented system of feedback and feed-forward will allow us to regulate the proton charge in each pulse to 1%
- The SC coils have been provided by ASG in Italy
- Beam has been extracted and factory tests are ongoing
- The first IBA S2C2 will be delivered to Nice (Fr) end of the year or early 2013

IBA 230 MeV S2C2

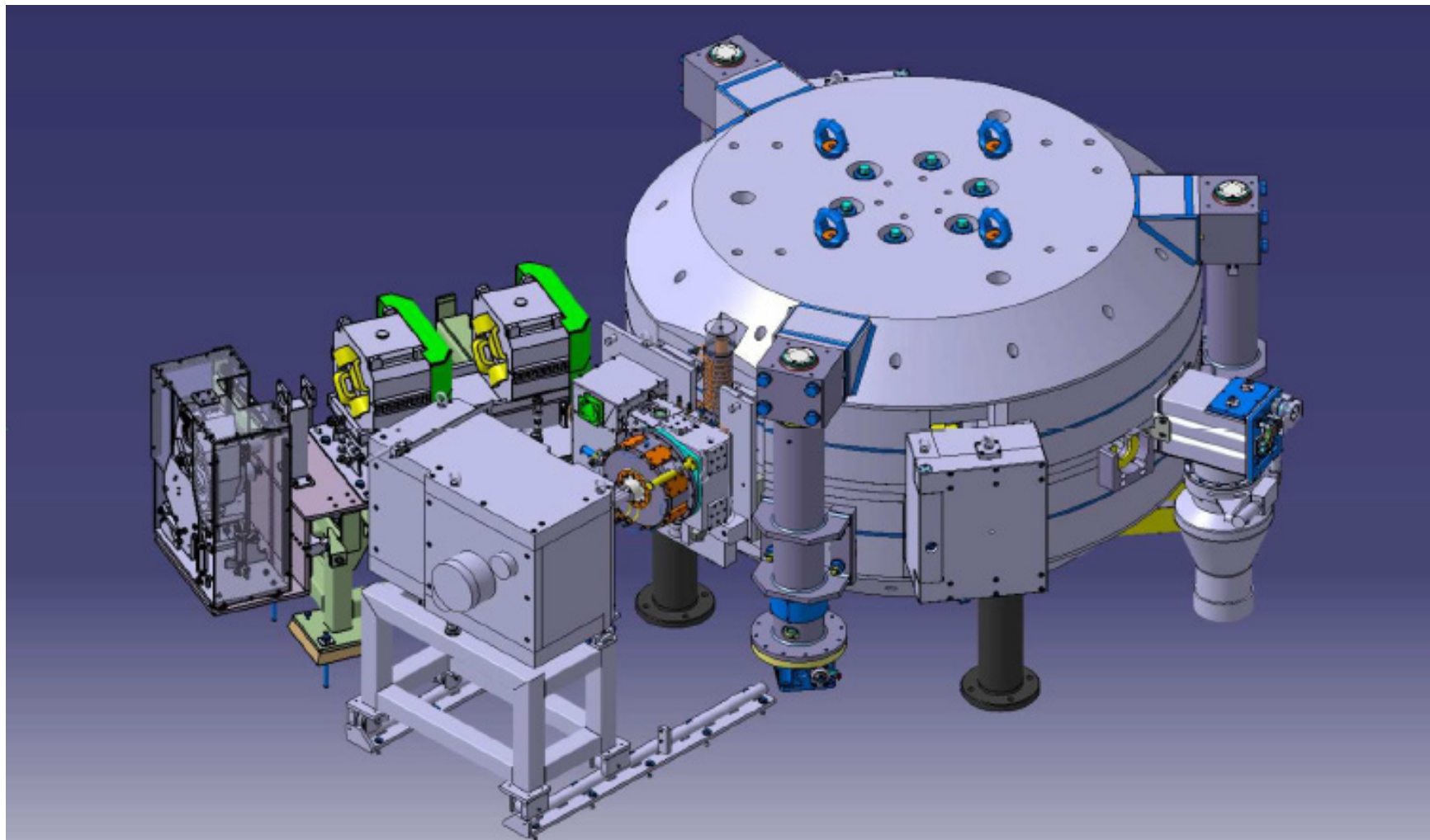

Insertable ion source and central region

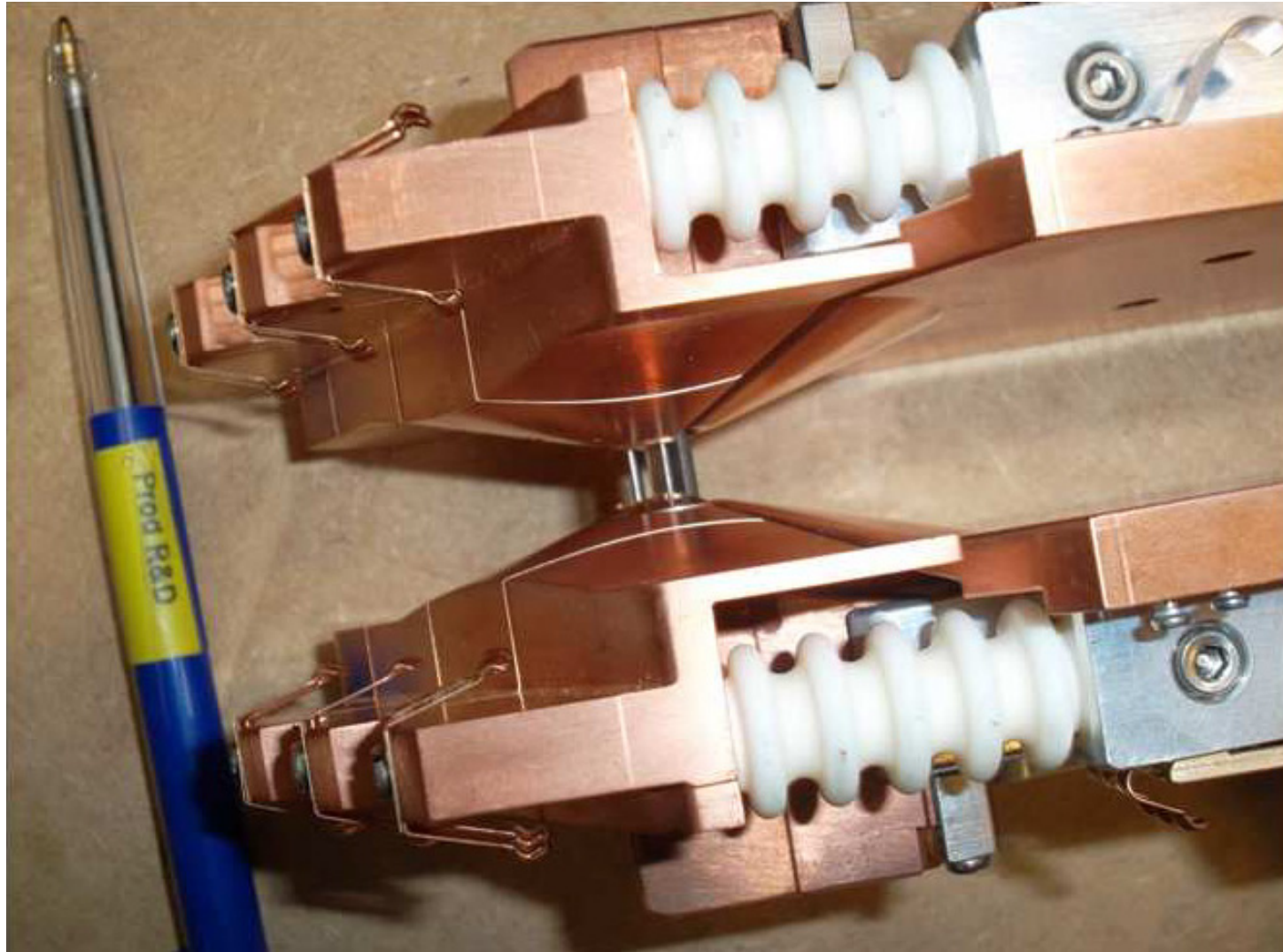

Extraction system of the IBA S2C2

- Harmonic coils
- Correction bars
- Regenerator
- Graphite beam stops
- Magnetic septum
- Anti-septum
- Harmonic coils
- 3 bar gradient corrector

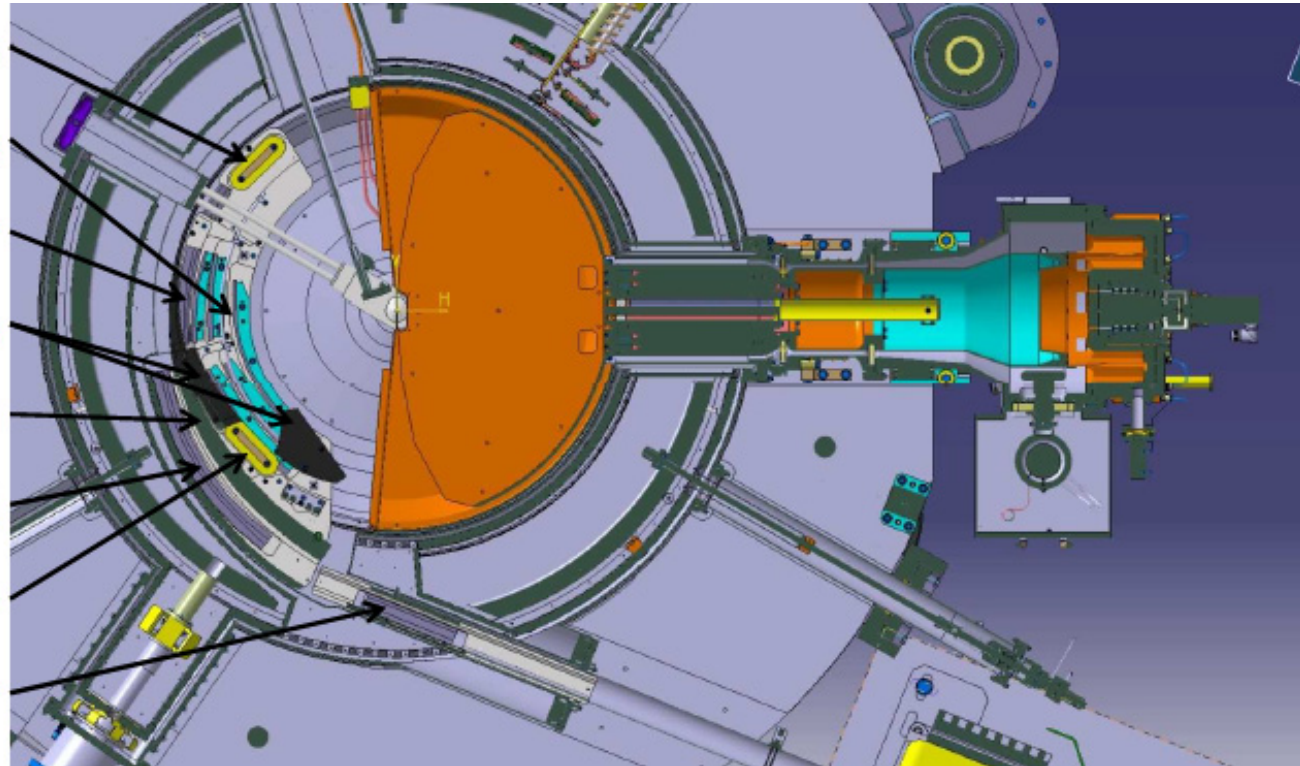

SC Isochronous cyclotrons for carbon beam therapy



A cyclotron for 400 MeV/u carbon ions?

- Synchrotrons are today the solution used everywhere for carbon beam therapy
- But this was also the case in 1991 in proton therapy when IBA entered the market. Today 75% of PT facilities use cyclotrons
- We believe that the reasons that made the success of cyclotrons in PT will also apply in carbon beam therapy, and that in 10 years the cyclotron will dominate also this market
 - Simplicity (one accelerator, not 3 in series)
 - Lower size and cost
 - Ability to modulate the beam current at kHz frequencies
- In the space and for the cost of a carbon synchrotron, you can install a cyclotron and a compact carbon gantry

Cyclotron view

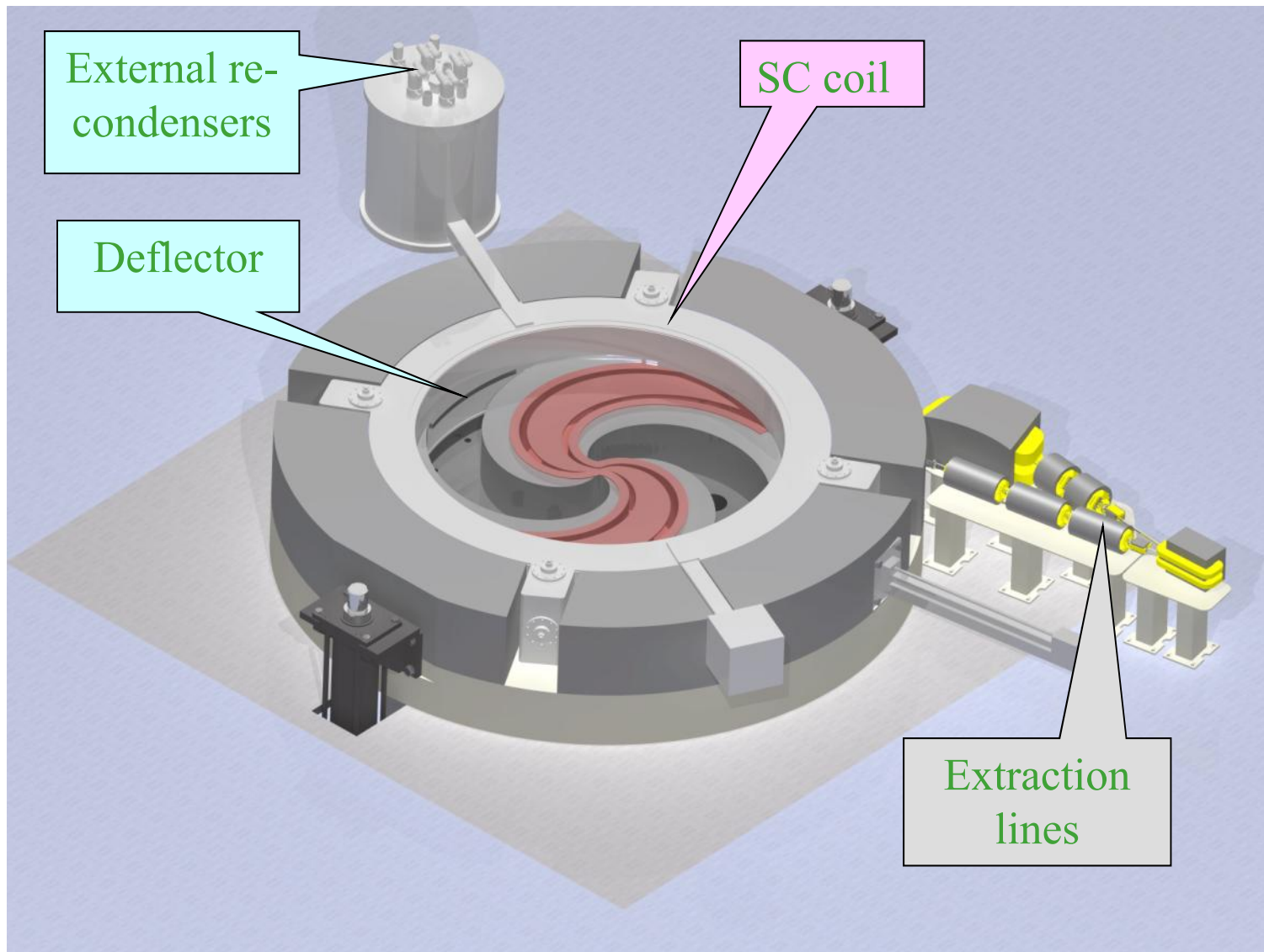

The cyclotron opens at the top of cryostat plane

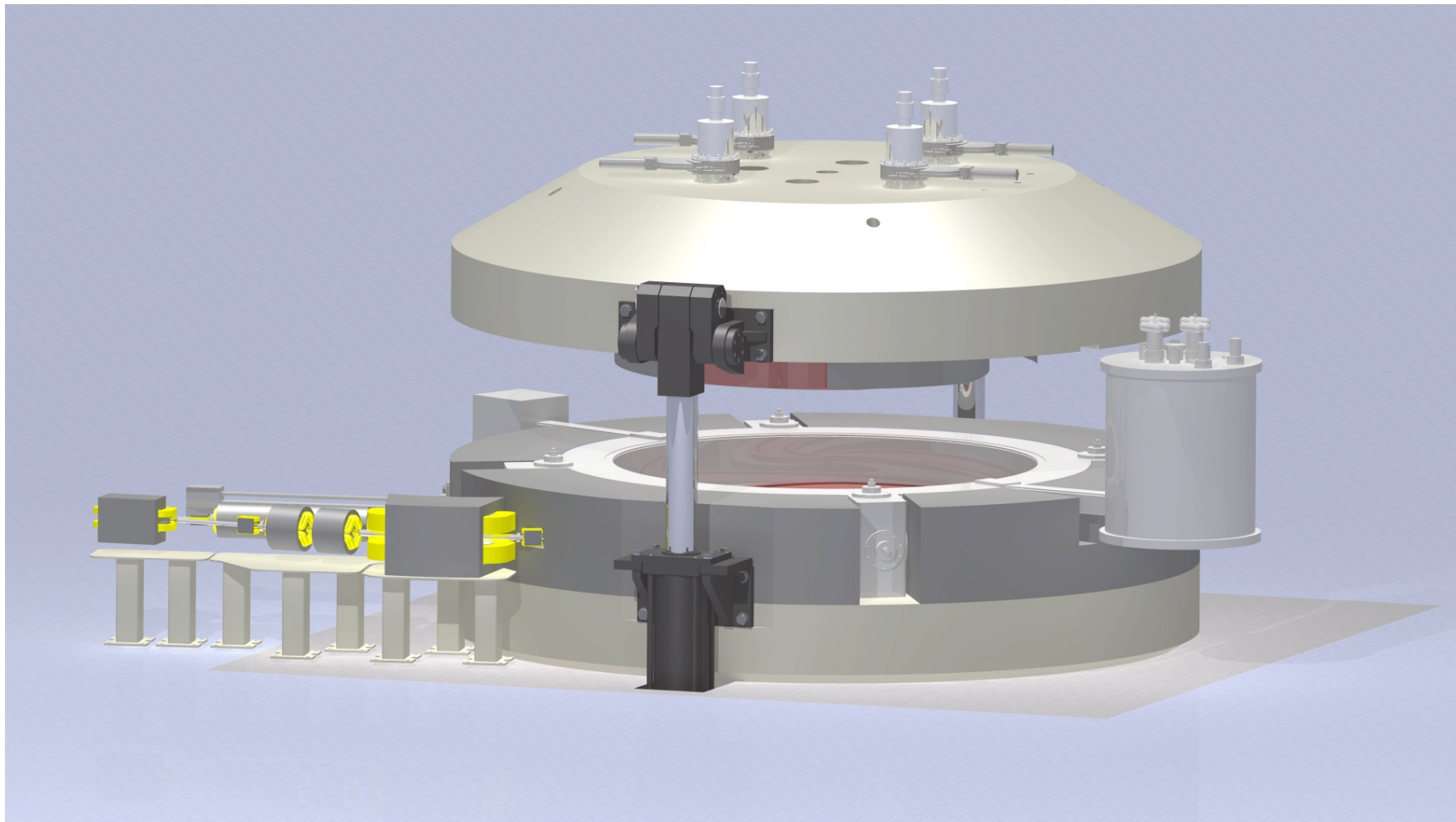

100% proton extraction by stripping at 265 MeV

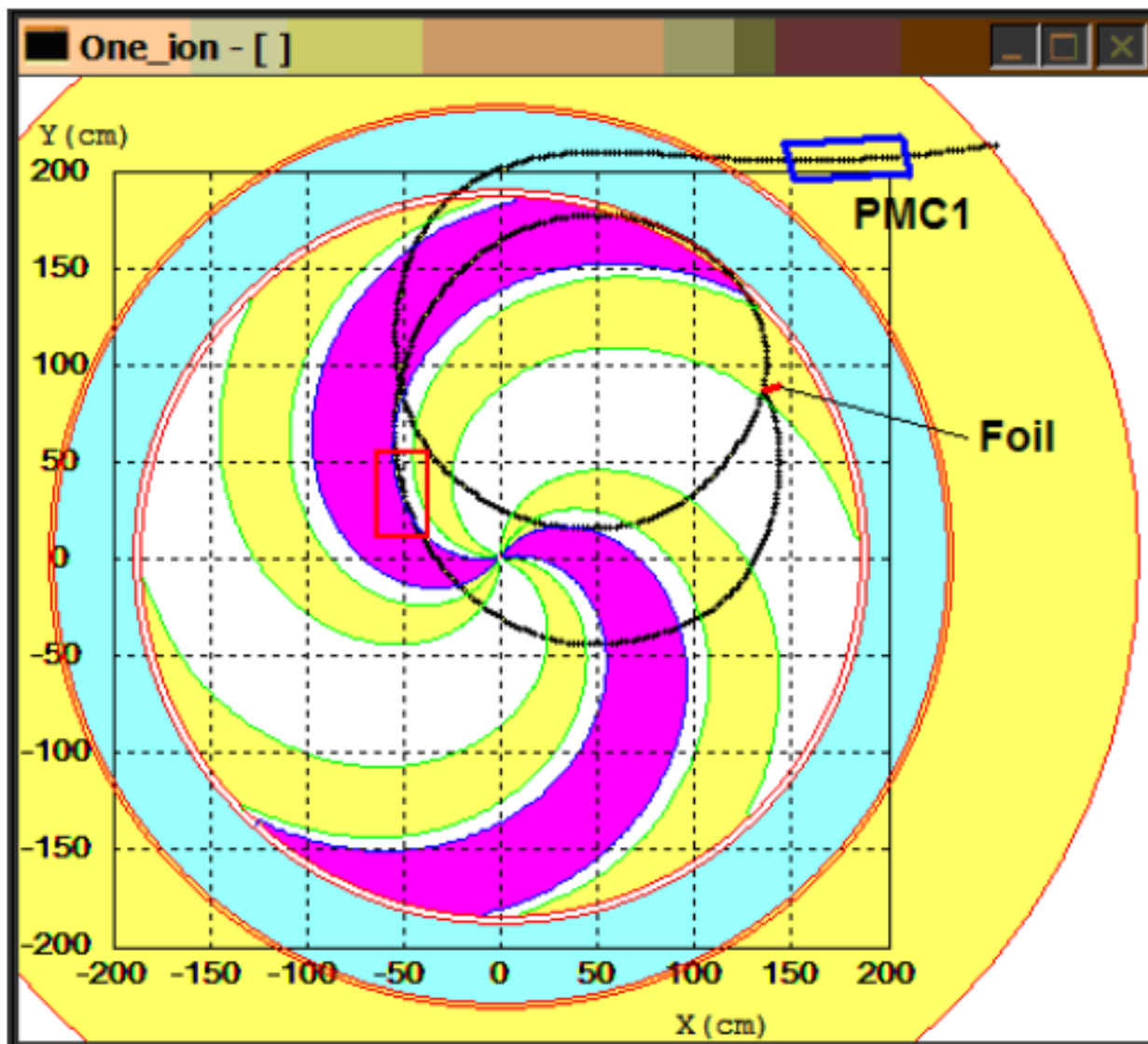

Proton & Carbon extraction elements

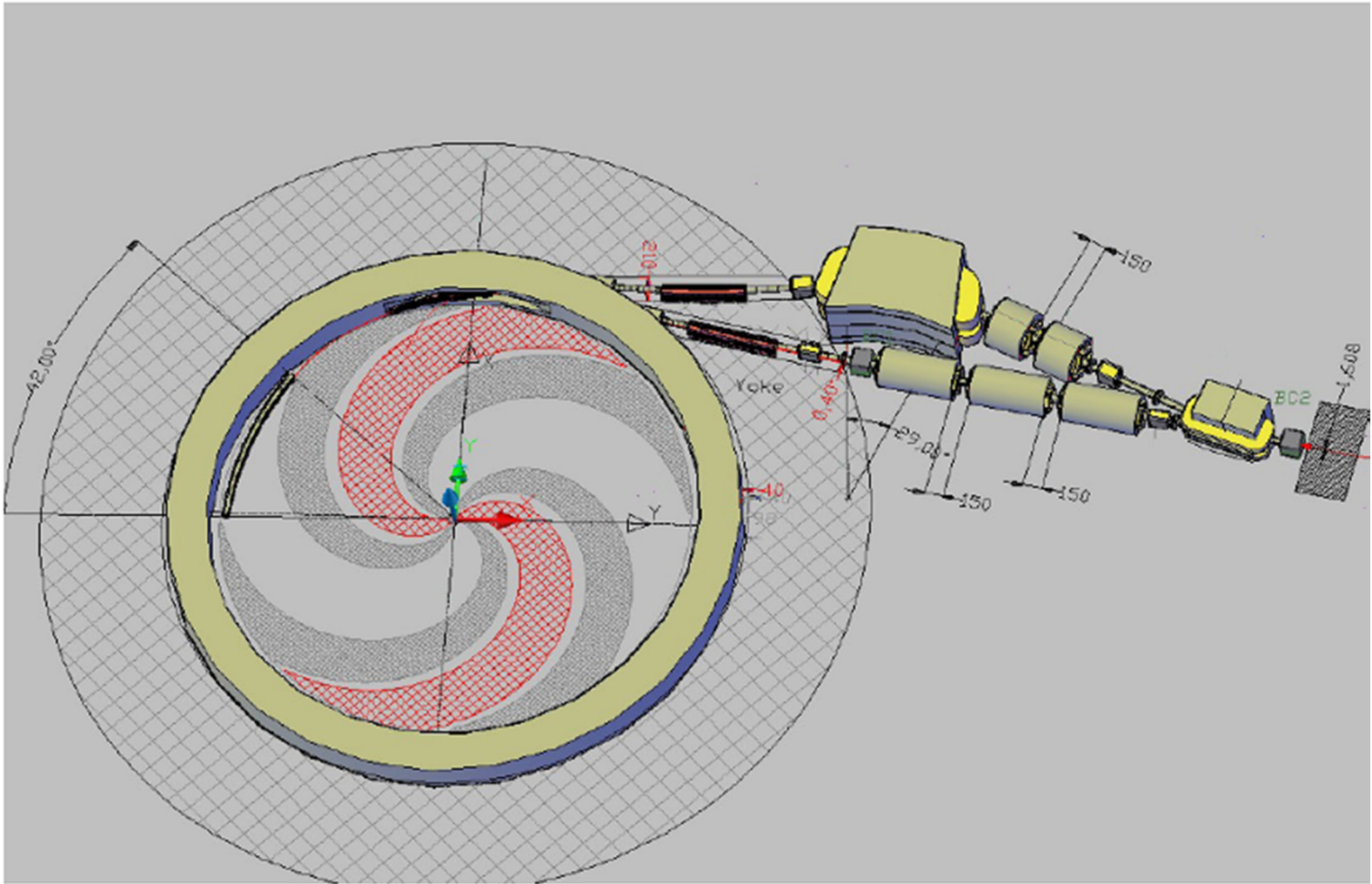

The IBA Carbon cyclotron design

- Superconducting isochronous cyclotron, accelerating $Q/M = 1/2$ ions to 400 MeV/U (H²⁺ + (up to 250 MeV/u), Alphas, Li⁶ 3+, B¹⁰ 5+, C¹² 6+, N¹⁴ 7+, O¹⁶ 8+, Ne²⁰ 10+)
- Design very similar to IBA PT cyclotron, but with higher magnetic field thanks to superconducting coils, and increased diameter (6.3 m vs. 4.7 m)

Commercialization of IBA carbon system

- ❑ In 2011 IBA signed a contract to sell the prototype of its carbon therapy system to Archade in Caen. This contract was subject to bank financing
- ❑ The bank financing was never obtained, and the contract became void end of 2012. One major reason of the bank reluctance was Siemens decision to pull out of carbon beam therapy.
- ❑ A new company “Normandy Hadrontherapy” , in which IBA would be a minority shareholder is now put in place to industrialize this carbon therapy system
- ❑ Financing is expected for the end of this year.

Thank you...

