

MECHANICAL DESIGN CONCEPTS OF DYNAMITRON ACCELERATORS

C. F. Mason

Radiation Dynamics, Inc.

Westbury, L.I., New York

Summary

On the basis of ready availability and reasonable cost, methyl methacrylate (lucite or plexiglass) has proven to be suitable for use as the structural material in the high voltage columns of Dynamitron accelerators. This material has reasonably high tensile strength, good machining characteristics, ready availability at reasonable cost, and good electrical properties such as high dielectric strength, high resistivity and resistance to surface tracking. The structures made of Acrylic material conform to standard forms of beam analysis provided deflections are kept within reason and stress within recommended limits. A 4.0 Mev column 15 feet long by 42 inches in diameter, supporting at a total weight of 1500 pounds is now in operation.

The cinch rod method of supporting beam tubes has proven to be practical and allows several side benefits, such as easy handling, allowing for short sections of the tube to be replaced if damaged, ease of insertion of apertures if and when required, and assembly of modular sections to any given length desired. A new method, a combination of cinch rods and counter weights, has proven a satisfactory improvement that still has these desirable features without requiring unreasonable cinch rod tension. A 4.0 Mev tube 12 feet long, weighing 480 pounds and carrying an ion source, lens and getter-pump assembly weighing 55 pounds at the high voltage end is now in operation.

Introduction

The rectifier stack structure described herein has slowly evolved over a period of 10 years to its present state of development in 4 Mev Dynamitrons.¹ Extensive experience and numerous design changes have led to a highly reliable, strong, semi-rigid support structure. The practicality of the design is attested to by over 25 working machines in the 1.0 to 3.0 Mev range. It has been necessary to overcome a lack of established design criteria for large stressed-plastic cantilever beams. Problems in the attachment

all been successfully solved. The acrylic material answers all of the necessary design requirements placed on it, that is, high d.c. stress, moderate r.f. stress, multiple holes for component mounting, and reasonably high mechanical stresses without creep. It was the transverse r.f. field configuration that ruled out the use of the segmented stack construction commonly used in electrostatic generators and gave rise to the present method of construction.

The beam tubes presently used in Dynamitrons are of the Turner type¹ using aluminum lenses, stainless steel dynodes, and glass insulators. The components are epoxied together in 2 foot sections which are held together with ceramic cinch rods. Vacuum integrity is maintained thru the use of Viton "O" rings. The cinch rods assume all tensile stresses while the members of the beam tube itself are in compression. The design of the 4 Mev beam tube incorporates a vertical support at the mid-point to relieve the stress buildup on base of the tube. With this feature, excessive cinch rod tension is not necessary for support while the advantages of the cinch rod design are preserved.

Design of Rectifier Stacks

On Dynamitron models thru the 3 Mev range, the stack is constructed of two simple slabs of acrylic material spaced apart by aluminum cross rods. This structure has the appearance of a box girder with the acrylic oriented as the vertical member. Early experience with four-sided box structures has shown that tracking will occur along glued or dry bolted points that run along the direction of voltage gradient. Therefore, all strength must be supplied by the acrylic side plates. As the design is extended for higher voltage machines, the length of the stack must be increased in proportion to the voltage. For practical reasons, the diameter (beam depth) of the stack is not increased in the same proportion. Therefore, the deflection must be limited by increasing the thickness of the slabs to achieve the desired section modulus.

In 4 Mev Dynamitrons a spaced sandwich construction of two acrylic slabs (Figure 1) was chosen to provide adequate section modulus with available 1/2" slab thicknesses. The length was extended with a single 3/4" slab as shown in Figure 2. The slabs are tied together by extending rectifier tube support posts thru both plates. These are drilled simultaneously so that the support bushing assumes equal loads. The stack was designed using standard beam formulas with appropriate allowed stresses being determined by experience. In designing with acrylic material it is important to keep the stress low to prevent long term creep or flow and prevent excessive deformation of the material. A practical limit to be observed for long term duty is 1500 psi tensile strength as an absolute maximum.

The rectifier stack analysis is treated in the following manner for single-ended Dynamitrons. (See Figure 2)

Treating the stack in Figure 2 as a cantilever beam that bears both uniform and concentrated load, it follows that the maximum deflection at the end will be the summation of the deflections caused by each load.

$$\int_T = \frac{P_1 L^3}{3EI} + \frac{WL^4}{8EI} =$$

$$\int_T = \frac{300(180)^3}{3(450,000)} + \frac{50}{12} \frac{(180)^4}{8(450,000)} (2483)$$

$$\int_T = .52" + .46"$$

$$\int_T = .98"$$

where,

P_1 = concentrated load (#)
 W = load per unit length (#)
 L = length (in)
 E = modulus of elasticity 450,000 (psi)
 $I = \frac{bh^3}{12}$ = section modulus
 $I = \frac{1"(31")^3}{12} = 2483 \text{ in}^4$
 \int_T = deflection (in)

The above results were verified by the actual deflection data obtained from full scale, long term test. The test data indicated a maximum deflection of 7/8" and a return to the original tram marks after one month under load. The loading used in the calculations applies to one side of the stack and under normal circumstances a load on the structure as a complete unit would be 100#/ft. dis-

tributed load plus a concentrated load of 600# at the end.

Since all load is transmitted by the pin and bushing arrangement this represents the second critical design point. Therefore, on the following basis:

$$\sum M_A = 0 = 50(180/12)(180/24) + 300(180/12)$$

$$-B(24.12)$$

$$0 = 5625 + 4500 - 2B$$

$$\therefore B = 5063\#$$

At the pin and bushings, doubling plates are used to distribute the load and 3" diameter bushing is used then;

$$S = \frac{P}{A} = \frac{5063\#}{3" \times 3"} \approx 563 \text{ psi}$$

This 563 psi is well within the allowable long term stress of 1500 psig. Further investigation into the maximum stress in the extreme fiber of the stack plates yield an answer of 600 psi which is again well below the allowable limits.

Since the cantilever stack conforms well to standard beam calculations, it follows that when a tandem Dynamitron is made the stack again may be treated as a standard beam in classical fashion. The tandem design can be approached with either a simply supported beam configuration or a constrained beam configuration. The latter has been chosen because it produces smaller deflections given the same length and section modulus.

The following arguments are used in developing the tandem stack design:

For a cantilever stack structure:

$$\int_{\text{Total}} = \int_{\text{Concentrated}} + \int_{\text{Uniform}}$$

$$\int_{\text{Concentrated}} = \frac{WL^3}{3EI}$$

$$\int_{\text{Uniform}} = \frac{WL^4}{8EI}$$

$$\int_{\text{Total}} = \frac{W_1 L^3}{3EI} + \frac{WL^4}{8EI}$$

\int = Deflection (in)

W = Total Load #

L = Length (in)

E = Mod. of Elast. (psi)

I = Section Mod. (in⁴)

and since $W_1 = 600\#; L=15$ feet; EI is a constant; $W_2 = 60\#/ft \times 15$ feet = 900# and the conversion of feet to inches can be factored out, it results that;

$$EI_{cant} = \int \frac{L^3}{3} \frac{W_1 + W_2}{8} = (15)^3 \frac{600+900}{8}$$

$$EI_{cant} \approx \frac{3375}{8} (200+113) \approx \frac{1,056,000}{8} \quad \text{Total}$$

For a constrained stack structure

$$\int Total = \int Concentrated + \int Uniform$$

$$\int Concentrated = \frac{W_1 L^3}{192 EI}$$

$$\int Uniform = \frac{W_2 L^3}{384 EI}$$

$$\int Total = \frac{W_1 L^3}{192 EI} + \frac{W_2 L^3}{384 EI}$$

and since $W_1 = 600\#; L = 32$ feet; EI is a constant $W_2 = 100\#/ft \times 32$ ft = 3200# and the conversion of feet to inches can be factored out it results that;

$$EI_{const.} = \int \frac{L^3}{192} \left[\frac{W_1}{192} + \frac{W_2}{384} \right] = \int \frac{(32)^3}{192} \left[\frac{600+3200}{384} \right]$$

$$EI_{const.} \approx \frac{32,800}{1/8} [3.1 + 8.3] \approx \frac{373,900}{8}$$

Since E is constant and in the case of the tandem the thickness of the material is increased by 50% to compensate for the added load of the beam tube the $I_{cant} = 1.5 I_{const.}$. Therefore:

$$EI_{cant} = \frac{1,056,000}{cant} = 1.5 EI_{const.} = \frac{373,900}{\int const.}$$

$$\therefore \frac{1,056,000}{\int cant} = \frac{373,900}{1.5 \int const.}$$

$$\int const. = \frac{373,900}{1,056,000} (1.5) \int cant.$$

$$\int const. \approx .24 \int cant$$

The derived equation, \int constrained = .24 \int cantilever indicates that under 150% stack loading and 130% beam tube loading the deflection will be .24 (27/32"), or approximately 7/32" based on actual measured deflection. This is to be compared to the 7/8" deflection of the cantilevered case. In other words, the tandem column is substantially stronger than the single-ended column. Simplifying assumptions that were made to arrive at this conclusion are:

1. The uniform load is constant on the stack which is conservative in that half the stack does not carry rectifier tubes.
2. The concentrated load at mid span is 600# which is 50% greater than presently designed terminals which include nanosecond pulsing, microsecond pulsing, and all necessary power supplies for Duo-plasmatron operation. In reality the 600# is distributed over 6 feet of terminal and is not exactly at mid span.
3. The beam tube weight will exceed by 30% the calculated weight and that entire weight will be assumed by the stack structure. Actually, approximately 10% of the weight will be supplied by the base supports.

Design of Beam Tubes

Beam tube construction represents a departure from normally accepted methods of construction and suspension. All Dynamitrons thru 3.0 Mev have cantilevered beam tubes. The tube is made up in several modular sections to the desired length. The cinch rods and beam tube are fabricated in 2 foot lengths and can be assembled in any multiple of 2 feet. The typical construction is shown in Figure 3.

The 2725# represents the spring tension required to keep the beam tube from pivoting downward about point A. However, a second mode of failure can occur by pivoting upward about point B. This would be caused by excessive tension in the upper rods. Assuming a tension of 500# in the lower cinch rods $\Sigma M_B = 0 = 40(8)(4) + 100(9) - X(.2) + 500(.6)$
 $\therefore x = 12,400\#$

Since the minimum tension required for downward equilibrium is 2725# and the maximum tensions to cause overturning is 12,400# this represents a large dead band region. The ideal setting is obtained by adjusting the cinch rods to the point where normal service may be carried out within the dead band. By choosing the ideal setting the maximum safety factor is obtained against accidental shock loads as illustrated in Figure 4.

The dead band concept indicates that the ion source may be removed without adjusting the cinch rods or providing added supports.

The methods of design for support of the high voltage column and beam tubes which have been described herein are convenient and reliable as tested by extensive field service in horizontally mounted machines. The same principles can be

used to build larger and heavier structures in the future.

Bibliography

1. M. R. Cleland and P. Farrell, "Dynamitrons of the Future".

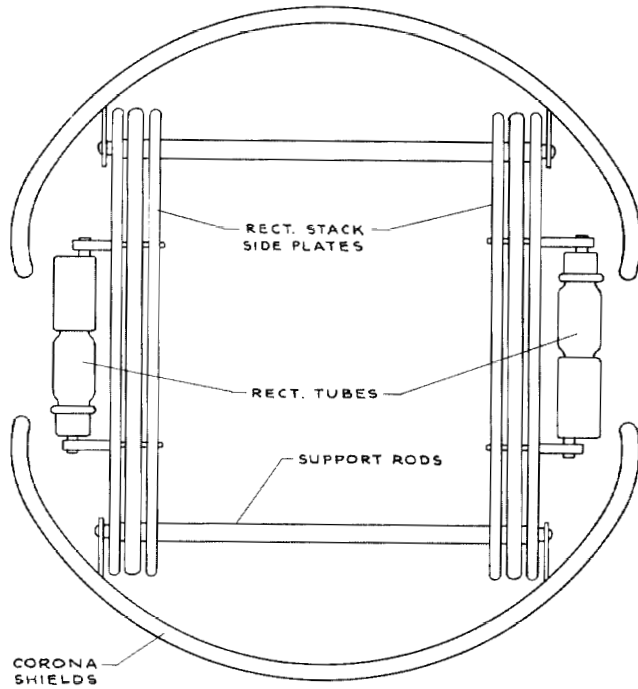

Fig. 1. Rectifier Stack Cross-section.

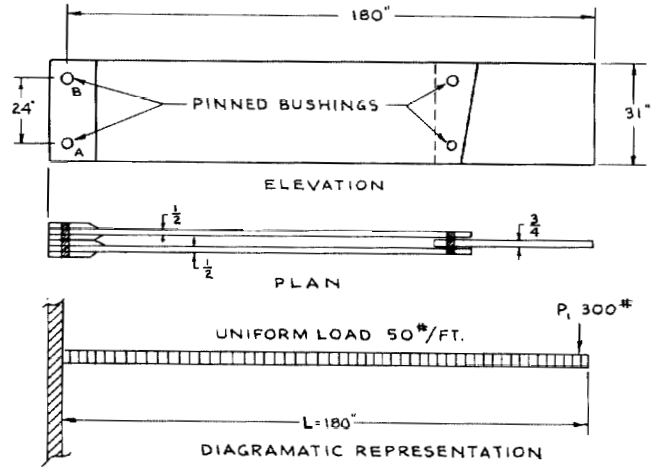

Fig. 2. Rectifier Stack Slabs.

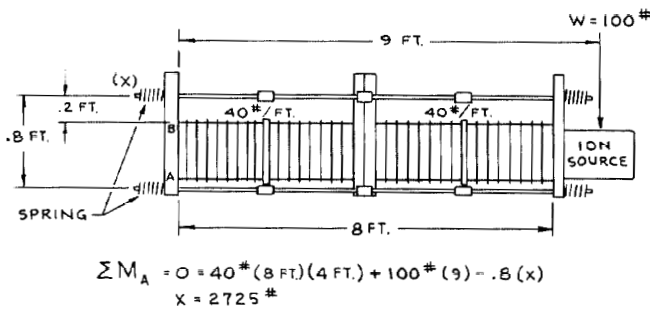

Fig. 3. Typical Beam Tube.

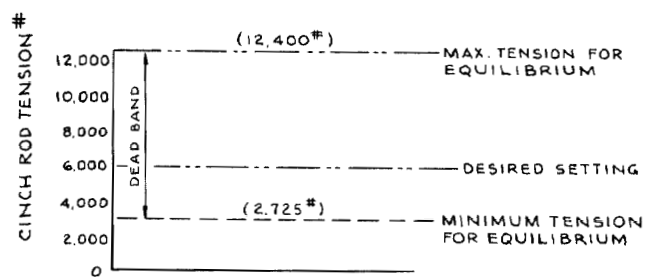

Fig. 4. Pictorial Stress Representation.