

IN DEPTH DIAGNOSTICS FOR RF SYSTEM OPERATION IN THE PEP-II B FACTORY*

Daniel Van Winkle**, John Fox, Dmitry Teytelman, SLAC, Menlo Park, California

Abstract

The PEP-II RF systems incorporate numerous feedback loops in the low-level processing for impedance control and operating point regulation. The interaction of the multiple loops with the beam is complicated, and the systems incorporate online diagnostic tools to configure the feedback loops as well as to record fault files in the case of an RF abort. Rapid and consistent analysis of the RF-related beam aborts and other failures is critical to the reliable operation of the B-Factory, especially at the recently achieved high beam currents. Procedures and algorithms used to extract diagnostic information from time domain fault files are presented and illustrated via example interpretations of PEP-II fault file data. Example faults presented will highlight the subtle interpretation required to determine the root cause. Some such examples are: abort kicker firing asynchronously, klystron and cavity arcs, beam loss leading to longitudinal instability, tuner read back jumps and poorly configured low-level RF feedback loop.

INTRODUCTION

The PEP-II Low level RF (LLRF) system is complex [1]. The high energy (electron) ring currently contains nine stations controlling a total of 26 accelerating cavities. The low energy (positron) ring currently contains four stations which control eight cavities. Each station is comprised of several modules installed in a VXI crate. The VXI crate is, in turn contained within a temperature controlled cabinet. Since the PEP-II storage ring is currently operating well in excess of the design current and there are plans to increase to well beyond existing record setting currents [2], system reliability must be actively monitored. To aid in troubleshooting, diagnostics, and monitoring, the designers of the system included fault diagnostics as part of the original design.

AVAILABLE DIAGNOSTICS

The main diagnostics are obtained through the use of recorded wave forms which are written out at the time of a fault or beam abort. When the beam is aborted due to either an external abort (something independent of the RF system) or due to the RF system, an abort trigger signal is sent to the LLRF system. This trigger signal tells the various modules (containing the capability to record data in a circular buffer at a 10 MHz rate) to stop recording and write out their buffers to the disk. There are currently four modules within the LLRF system which record fault

files on an abort. These are: The RFP (RF Processing Module), the IQA (IQ and Amplitude Detector Module), the GVFF (Gap Voltage Feed Forward Module), and the AIM (Arc Interlock Module).

The RFP module has two sets of memory (cavity and signal). The cavity memory can be set to record any (but only one) of the (up to) four cavities in a station. The signal memory can record various signals around the direct and comb loops. The RFP records complex I&Q signals. Figure 1 shows a block diagram representation of the signal recording points. Typically, the RFP is set up to record the drive signal into the signal memory and one of the cavities into the cavity memory.

The IQ&A modules [3] contain eight channels with each channel monitoring the signals both in a (slow) complex as well as a (fast) amplitude only sense. The fast amplitude detector is used for triggering an abort if necessary. The IQ (inphase=I quadrature=Q) detectors are used for signal monitoring as well as in slow EPICS based loops. Each station contains at least two IQ&A modules. Four cavity stations will contain three IQ&A modules. The signals which each IQA module monitors are shown schematically in Figure 1. A Four cavity station would simply show one more module monitoring the other two cavities in the same manner as IQA2.

Currently, two flavors of IQ&A modules exist. The older version can only monitor 1 channel at a time. The newer version can monitor eight channels at once by multiplexing the channels before the ADC. This multiplexing reduces the sample rate by a factor of eight, but allows for much more detailed diagnostics. The older IQ&A modules are installed in the position for IQA1 which only records the klystron output forward power in event of a fault. The newer version IQ&A modules monitor the cavity forward and reverse powers as well as the probe signals (used for gap voltage setting) and write all these signals out in the event of an abort.

The Gap Voltage Feed-Forward module [4] produces the adaptively generated I and Q reference signals for each RF station. The only fault file produced by this module is that of the woofer channel. The woofer channel is used to provide a low-frequency longitudinal correction kick via the RF system. This signal now comes from the recently commissioned low group delay woofer (LGDW) [5].

The arc interlock module together with a companion unit, the ARC chassis, implements the fast interlock controls for the each station. The AIM module has recently been modified to record both the current and voltage of the HVPS which feeds the PEP-II RF klystrons. This new feature will be a great help in separating HVPS/Transformer arcs from klystron arcs.

* Work supported by U.S. Department of Energy contract DE-AC02-76SF00515

** dandvan@slac.stanford.edu

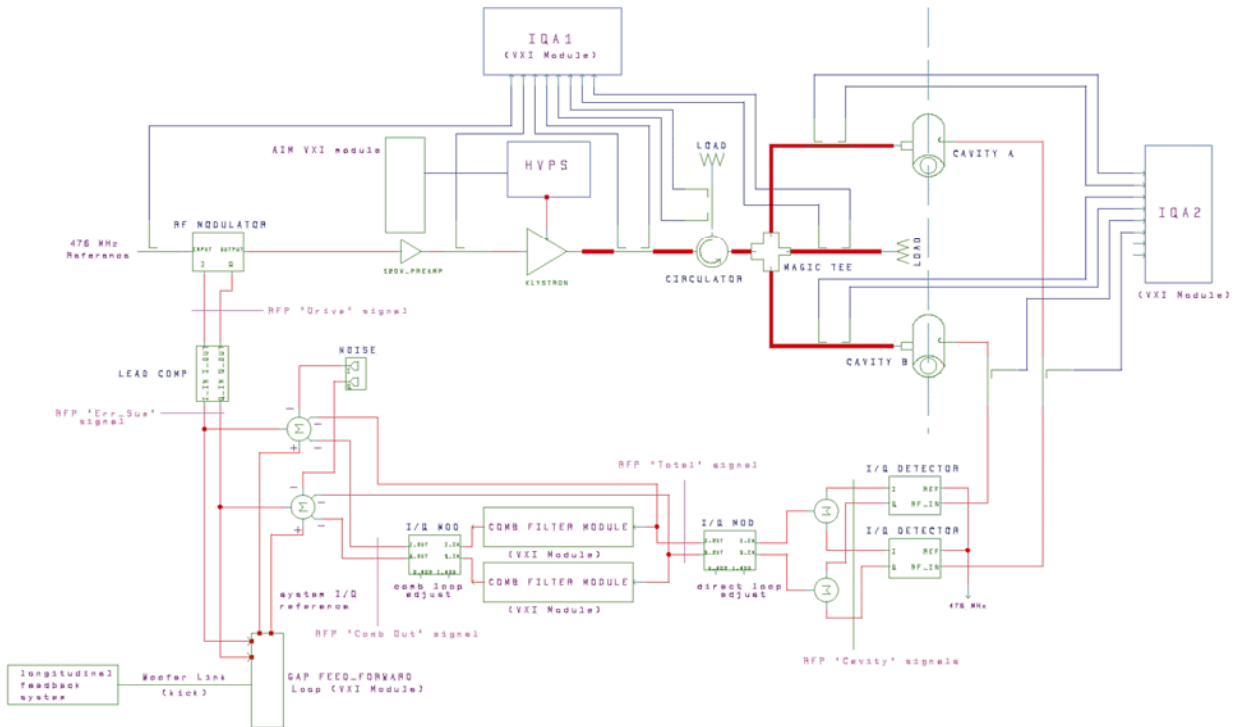

Figure 1: PEP-II LLRF signal diagnostic block diagram.

DIAGNOSTIC TECHNIQUES

Each abort initiated by the RF system results in fault files being written by the various modules. The EPICS system allows for up to 15 aborts to be kept in a circular file buffer. The station which instigated the abort is usually latched by the main control center (MCC) and the operators are the ones who report (in their log) which station aborted. Unfortunately, the station which latched may or may not be the station that actually caused the abort. The steps in attempting to determine what caused an abort include determining which station initiated the abort and then looking at the various fault files for that station. An example will be the best way to clarify the process.

The first step to identify an abort is to look in the online operation log. For this example, the operators reported the following: "Abort: (1) HER 12-1 RE abort". HER 12-1 is simply the nomenclature used to identify which station in the High Energy Ring (HER) is being referenced. An RE abort simply means that reflected energy from one of the cavities exceeded the diode detector threshold set in the IQ&A module. The next step is to look into the written log to see if any further information is available. The written log shows: "0117 HER 12-1 RE abort" which gives the exact time to within 2-3 minutes and aids in determining which fault file to look at. Another place to look is the CMLOG which contains a history of all the various commands that scroll across the operations console. A typical abort will cause all stations to trip so often it is very hard to discern which

one actually cause the abort. For this abort, no useful information was contained in the abort listing from the CMLOG. The next step is to begin looking at the fault files. This is done using various matlab scripts written to analyze and plot the data.

RE aborts can be caused by any number of things, but for PEP-II the usual cause is cavity arcs. HER station 12-1 does not have an 8 channel IQ&A module for IQA2 (it normally would). As a consequence, we cannot look at the reflected power from the cavities. We can, however, do a two cavity plot using the data from the RFP. Since we have had problems with this station before, we have set up the RFP to record the "total" signal into the signal memory and the cavity A signal into the cavity memory. By subtracting the cavity A signal from the total signal we can generate a plot of both cavity's signals using matlab. Shown in Figure 2 is the result of this operation.

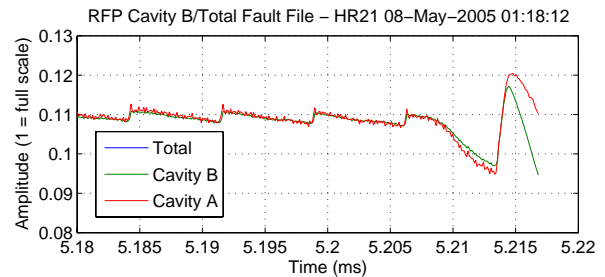

Figure 2: HER 12-1 Gap Voltage at abort.

The traces shown in Figure 2 do not look like an arc. One can see the recurring gap transient induced by the beam, and after the last turn the beam simply goes away

(aborted). The conclusion at this point is that HER 12-1 did not actually cause this abort. At this point it is customary to look at all the forward klystron powers from the abort in question. By carefully looking at the faults, it may be possible to see a station which is behaving differently at the abort. Shown in Figure 3 is a plot of all the forward powers from this abort. HER 8-1 has been pulled out into its own plot to show the difference for this abort. Notice that at approximately 5.18 ms all the other stations in the high energy ring begin ramping up in power. HER 8-1 doesn't show this effect at all. In fact it isn't until 5.2 ms that the station shows a rapid rise in power in approximately 5 μ s. Since the IQA modules in the varying stations will receive the abort trigger at differing times, it is not possible to line up these traces. What has really happened in this abort is that HER 8-1 actually had its arc at about 5.18 ms. It then takes several microseconds for the trigger signal to reach the other stations in the high energy ring.

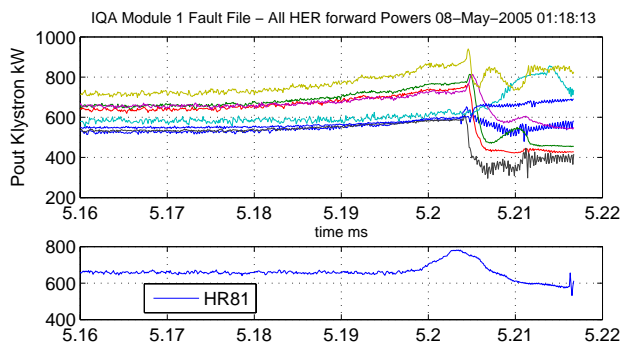

Figure 3: All Klystron forward powers in HER.

We can now identify that HER 8-1 may actually be the culprit in this abort, so we take a closer look at that station's fault files. Figure 4 shows the four cavity probe signals from HER 8-1 for this abort.

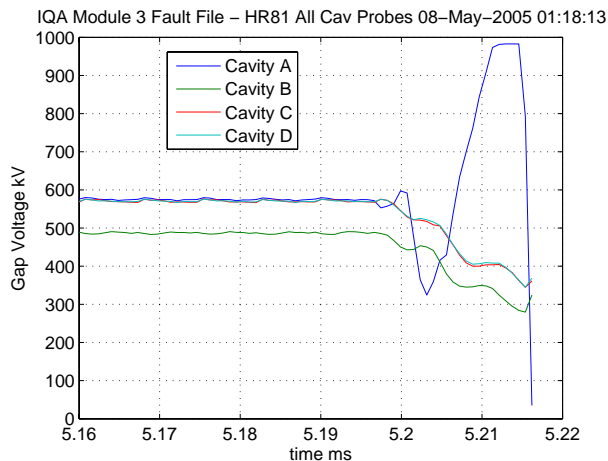

Figure 4: HER 8-1 Cavity A arc.

Clearly, the cavity A probe is seeing some extreme signals in the cavity. Since the IQ&A modules only record the amplitude information and since there is no filtering in front of the detector diode, we have no real information on the abort other than the large signal

amplitude generated within the cavity. The final thing to look at for confirmation of an arc is the reflected energy from cavity A. It should be significantly higher than the other cavities and should increase much more quickly. This is indeed what happens and is shown in Figure 5.

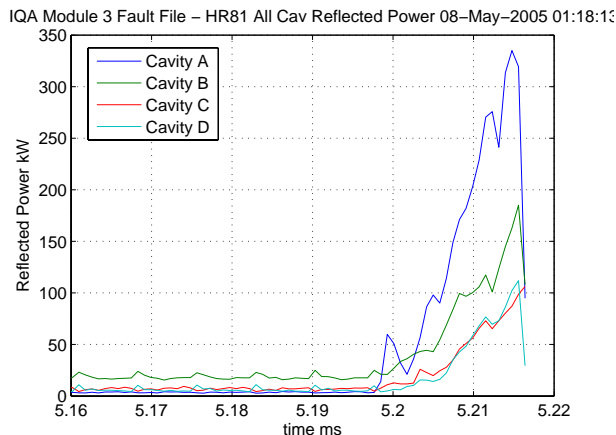

Figure 5: HER 8-1 Reflected Power.

CONCLUSIONS

Rapid and concise diagnostics of RF aborts to root cause is critical for maximizing the "up" time of the PEP-II RF system. Typical aborts include cavity arcs, klystron arcs, RF system hardware failures, and longitudinal instabilities due to beam loss. By diligently monitoring fault files and training operators we have been able to increase beam currents in the PEP-II systems to well beyond the original design goals. Because the goals for the remaining running time of the PEP-II system require ever increasing beam currents, we will continue to make modifications and upgrades to the abort diagnostics system. As we push to higher currents, even more timely and in situ diagnostics will be necessary.

Without the foresight of the original designers of the LLRF system (especially Paul Corredoura), the task of identifying and mitigating problems in the PEP-II RF system may have been an insurmountable task.

REFERENCES

- [1] P. Corredoura, "Architecture and Performance of the PEP-II Low-Level RF System" (PAC-1999), New York City, NY, March 29-April 2, 1999.
- [2] P. McIntosh, et al, "PEP-II RF System Operation and Performance". EPAC-2004-TUPKF062, Jul 2004. 3pp.
- [3] C. Ziomek, P. Corredoura, "Digital I/Q Demodulator" PAC-1995:2663-2665 Dallas, Texas, 1-5 May 1995.
- [4] W. Ross, R. Clauss, L. Sapozhnikov "Gap Voltage Feed-Forward Module for PEP-II Low Level RF System", (PAC-1997) Vancouver, BC, Canada May 12-16 1997
- [5] D. Teytelman, J. Fox, D. Van Winkle "Operating Performance of the Low Group Delay Woofer Channel in PEP-II", these proceedings