

CONTROL SYSTEM FOR THE ORNL MULTICHARGED ION RESEARCH FACILITY HIGH-VOLTAGE PLATFORM*

M. E. Bannister[†], F. W. Meyer, and J. Sinclair, ORNL, Oak Ridge, TN 37831-6372, USA

Abstract

A control system for the 250-kV platform and beamlines for accelerating and transporting ions produced by an all-permanent-magnet ECR ion source has been developed at the ORNL Multicharged Ion Research Facility. This system utilizes the Experimental Physics and Industrial Control System (EPICS) software to manipulate a programmable logic controller (PLC) and its associated I/O points. Additional control points are accessed by the EPICS Input/Output Controller (IOC) via RS-232 and GPIB interfaces. The Allen Bradley ControlLogix chassis located at each of the electrical potentials of the installation, that is at the source, platform, and ground potentials, are interconnected via Ethernet utilizing fiber optic transmission to bridge the different high voltage environments. The user interface for the EPICS IOC is built with the Extensible Display Manager (EDM) software. Performance of the control system during initial experiments using the high-voltage platform will be reported.

HIGH-VOLTAGE PLATFORM

A new high-voltage platform and all-permanent-magnet ECR ion source have been installed and operated at the ORNL MIRF. More details can be found elsewhere in these proceedings [1]. The ion source [2], designed and fabricated at CEA/Grenoble, produces intense dc beams of singly and multiply-charged ions using up to 750 W of microwave power in the 12.75 - 14.5 GHz range and can be operated at source potentials up to 30 kV. The platform can provide up to an additional 250 kV of acceleration, yielding ion beams with energies up to 280 x q keV (where q is the charge state of the ions of interest) for use in fundamental collision studies with electrons, atoms, and surfaces.

CONTROL SYSTEM

The basic organization of the control system is indicated by the network diagram shown in Fig. 1. Allen Bradley ControlLogix chassis are located at each of the electrical potentials present in the installation: one at the ECR source potential (up to 30 kV above the platform potential), one at the platform potential (up to 250 kV above ground), and two at ground potential. The individual components of the control system are connected via Ethernet, with fiber optic transmission used to bridge the large potential differences between the sections.

The control system provides the basic equipment interlocks for operation of the ion source, platform, vacuum system, and beamlines. In addition, the control system supplies additional safety interlocks to supplement hard-wired interlocks used on the safety enclosure surrounding the high-voltage platform.

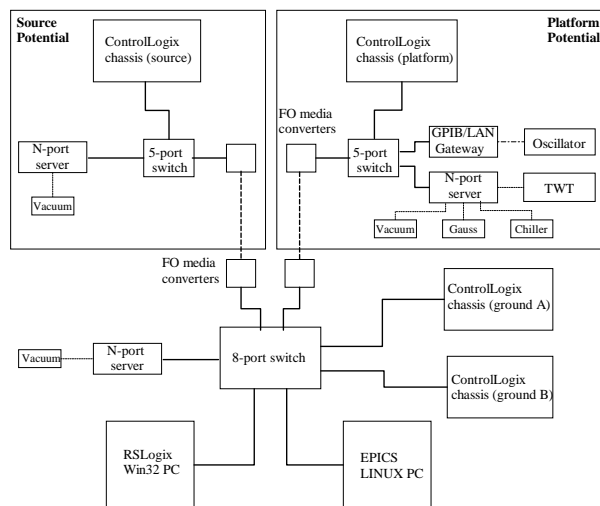

Figure 1: MIRF high-voltage platform control system network diagram. Fiber optic (FO) transmission is used to bridge the Ethernet communication across the high-voltage steps.

PLC

An Allen-Bradley Logix5555 PLC located in one of the chassis at ground potential (see Fig. 2) controls the I/O points for all four chassis via Ethernet. Of the 228 I/O points presently used in the control system, roughly one-third are assigned to operation of the ion source and platform, with the other two-thirds assigned to the beamline sections used to transport the ion beams to experimental end-stations. Because of the modular nature of the ControlLogix architecture, our control system can easily be expanded as additional components and beamlines are added.

The PLC operates on Rockwell Automation RSLogix5000 software and is programmed using a Win32 based PC. The ladder logic program in the PLC is built around a main operating loop: check the status of the ControlLogix chassis and I/O modules and the EPICS IOC, transfer I/O data into buffer arrays, make a “snapshot” of the system state, check the interlocks, and finally process outputs from the EPICS IOC. The ladder logic program is designed to process the interlock checks

* Work supported by OBES and OFES of the U. S. Department of Energy under contract DE-AC05-00OR22725 with UT-Battelle, LLC.

[†] bannisterme@ornl.gov

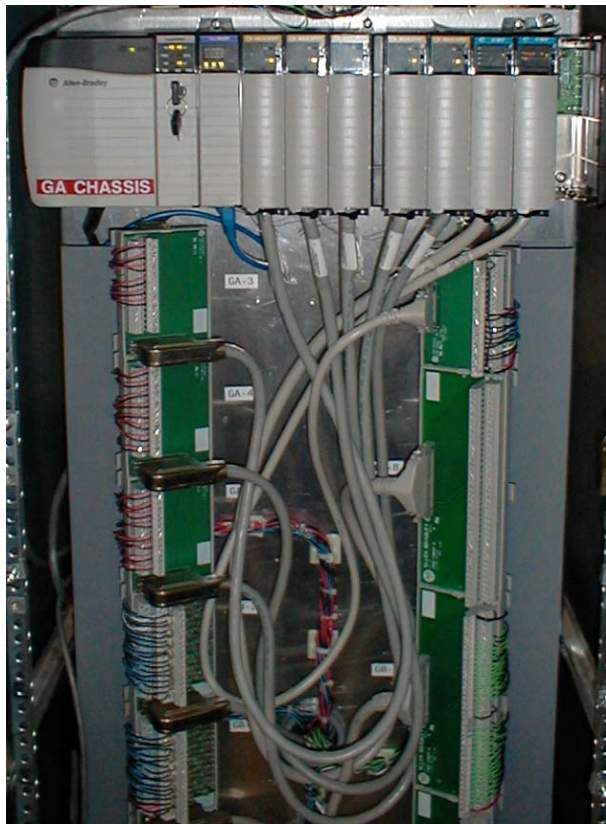

Figure 2: Ground potential ControlLogix chassis with PLC and field wiring.

continuously without data from the EPICS IOC so that the PLC can perform its protection functions even when the IOC is shut down.

EPICS

The EPICS [3] IOC manipulates the control system using a real-time database of records known as “process variables,” consisting of direct mappings of the PLC I/O points as well as information on the status of the ControlLogix system. In addition, the EPICS IOC has I/O points not connected to the PLC that are controlled through RS-232 and GPIB interfaces using the appropriate device drivers over Ethernet. The RS-232 devices are serviced via Moxa N-Port servers that are connected to the network, one at each electrical potential. Presently, three Varian Multi-gauge vacuum gauge controllers and the travelling-wave-tube (TWT) microwave amplifier on the ECR ion source are controlled by this means. Control of a Gaussmeter for the platform beam-analyzing magnet and of the recirculating chiller for cooling the source permanent magnets is under development. The frequency-tunable microwave signal generator is controlled from EPICS with GPIB via an Agilent E5810A LAN/GPIB gateway. The input records in the EPICS database are refreshed at 10 Hz and 1 Hz, depending on the priority of the I/O point and the speed with which it can respond; the RS-232 devices are generally

polled at 1 Hz. The control system voltage read-back from the ion beam optic elements is achieved using the voltage monitor outputs of the power supplies. These voltages are calibrated in the EPICS database using measurements performed with a precision voltage divider; this is especially important for the ECR ion source voltage and the platform voltage since these together determine the final energy of the accelerated ion beams delivered to the various experiments.

The control system takes advantage of the “simulation” feature of the EPICS software, permitting testing of the configuration without affecting any connected hardware devices.

EDM

The graphical user interface (GUI) provided for platform operators is built with the Extensible Display Manager (EDM) software [4]. The control system screens are organized in sections mimicking the platform and beamlines. A control screen for the ECR ion source and high-voltage platform is shown in Fig. 3. Most of the individual components are manipulated using a standardized set of controls and monitors to simplify ion beam tuning. For example, the high-voltage power supplies have an “enable” control and monitor, voltage control and readback, and for supplies where beam-loading may be important, also a current monitor. For electrostatic quadrupole triplet lenses used in the beamlines, a special combination of operator controls was developed that allow the four power supplies for one lens to be “locked” together at the same voltage amplitude (negative and positive as required), or in pairs of positive and negative supplies, or as four independent supplies. We found that this made coarse- and fine-tuning of these lens more practical.

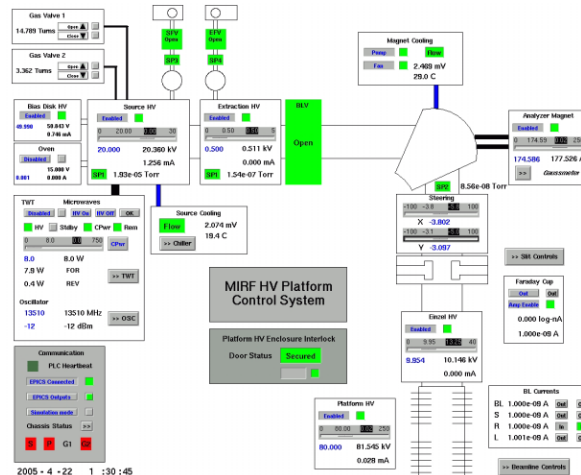

Figure 3: Control screen for the ECR ion source and high-voltage platform built with EDM.

OPERATION

The control system has been utilized during a recent experimental run in which the ion source and platform were operated continuously for over 100 hours with only one minor fault in the system due to a failing vacuum gauge. A typical mass-to-charge ratio scan for argon ions extracted from the source at 20 kV is shown in Fig. 4. The mass scan is accomplished using the XYGraph widget of EDM to plot the ion beam current and analyzing magnet current (proportional to the magnetic field) from the EPICS database.

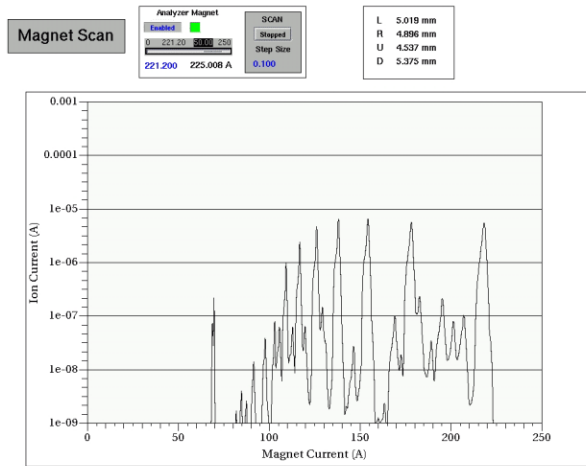

Figure 4: Mass-to-charge ratio spectrum of argon ions extracted at 20 kV from the ECR ion source. For a reference, Ar^{3+} is found at 176 A. Note the logarithmic scale for the ion beam current.

Implementation of other features of this control system will continue, with the addition of controls for a Gaussmeter on the analyzing magnet and for the ion source recirculating chiller. Other features such as diagnostic monitoring of control points as a function of time and archiving of ion beam tuning parameters are also planned.

REFERENCES

- [1] F. W. Meyer et al, "The ORNL Multicharged Ion Research Facility (MIRF) High Voltage Platform Project," these proceedings.
- [2] D. Hitz et al, *Proceedings of the 16th International Workshop on ECR Ion Sources*, Berkeley, CA, Sept. 26-30, 2004, AIP Conference Proceedings 749, New York, 2005.
- [3] L. R. Dalesio *et al.*, Nucl. Instruments Methods in Physics Research A **352**, 179-184 (1994).
- [4] <http://ics-web1.sns.ornl.gov/edm/index.php>