

STATUS OF THE BOOSTER SYNCHROTRON FOR DUKE FEL STORAGE RING*

S.Mikhailov[#], V.Litvinenko, M. Busch, M. Emamian, S.Hartman, I.Pinayev, V.Popov, G.Swift, P.Wallace, Y.Wu, FEL Laboratory, Duke University, Durham, NC 27708, USA

N.Gavrilov, Yu. Matveev, D.Shvedov, N.Vinokurov, P.Vobly
Budker Institute of Nuclear Physics, Novosibirsk, Russia

Abstract

In this paper we present current status of the Booster Synchrotron for the Duke FEL storage ring. The Booster which is recently under design, fabrication and construction, will provide full energy injection into the storage ring at energy from 0.3 to 1.2 GeV. The Duke storage ring FEL (SR FEL) operates in lasing mode with 193-700 nm wavelength range. The geometry of the Duke SR FEL provides for interacting head-on collision of e-beam and FEL photons. This mode of operation is used to generate intense beams of γ -rays from 2 MeV to about 200 MeV (currently from 2 MeV to 58 MeV). Generation of γ -rays with energy exceeding 20 MeV causes the loss of electrons, which will be replaced by injection from the Booster operating in a top-off mode. The paper presents design and status for elements of magnetic system and vacuum system, as well as design and parameters of fast extraction kicker with 11 nS pulse duration. All these element are designed and will be fabricated by Budker Institute of Nuclear Physics, Novosibirsk, Russia.

BOOSTER LATTICE AND DESIGN

The Duke Booster synchrotron is relatively compact 31.9 m circumference machine with race-track shape (fig.2). Two arcs are separated by 6.24 m straight sections accommodating RF cavity, injection and extraction kickers and septum magnets. The total circumference of the machine is exactly 19 RF wave lengths of the storage ring. Since the initial reported version of design [1] we increased the length of the straight sections by one RF wave each. RF frequencies of the main Duke storage ring and the Booster are identical. Two additional defocusing quads were also added into the straight sections. These modifications allowed us to relieve aperture constrains for single kick vertical injection and extraction [2].

The lattice of the Booster consists of 6 effective triplets, two of them, those in the middle of the arcs, have a virtual defocusing quads made by vertically focusing dipole edges. Lattice is optimized for the fast 11 nS pulse kicker providing for the single bunch extraction [2]. One of the major requirements for the magnetic design was fitting the Booster into existing storage ring room to avoid cost extensive building construction.

The shortest operation cycle is 2.5 sec (Fig.1) which is determined by maximum required average extraction rate from the Booster to the storage ring of up to 4-5 nC/sec. Therefore, the ramp of energy from injection $E=0.27$ GeV

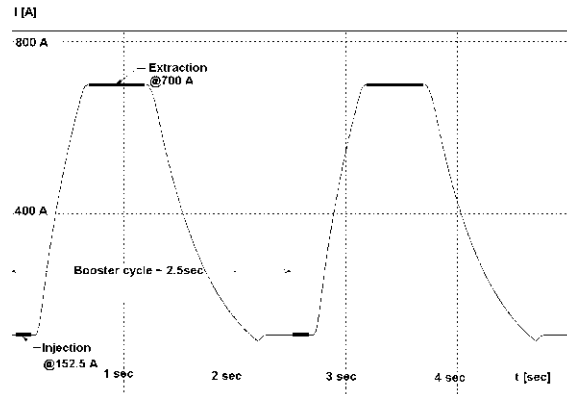

Figure 1: Booster shortest operation cycle $T=2.5$ sec.

to extraction of up to $E=1.2$ GeV has to be as short as 0.5-0.8 sec.

MAGNETIC SYSTEM

Magnetic system of the Booster includes 12 bending magnets with parallel edges, 8 focusing and 8 defocusing quadrupoles, injection and extraction septum magnets of Lamberson type, 4 focusing and 4 defocusing sextupoles for chromaticity correction, 4 strong (10 and 12 mrad) vertical trim dipoles producing a local orbit bump prior to injection and extraction, and four weak (up to 2 mrad at $E=1.2$ GeV) horizontal trim dipoles for injection and extraction orbit correction. All the bending dipoles and quadrupoles of the Booster are fed by single power supply [2] with maximum current $I=700$ A for $E=1.2$ GeV (Fig.1). There is also vertical orbit trim in each quad and horizontal orbit trim in each bending dipole. The maximum strength of those trims at $E=1.2$ GeV is 1.75 mrad for the vertical in quads and 10.5 mrad for the horizontal in the dipoles.

There are three quadrupole families, two focusing (QF1 and QF2) and one defocusing (QD). Parameters of the quads are listed in Table 1. The aperture of the quads is $D=50$ mm. The required variety of the quad strengths is provided by combination of three types of coils and two

Table 1: Parameters of Booster quadrupoles

Type	Qt y	Turns per pole	L_{eff} [cm]	L_{core} [cm]	$E=1.2$ GeV	
					G_{max} [T/m]	K1 [m ⁻²]
QF1	4	10	0.151	0.146	27.62	6.901
QF2	4	7			19.54	4.882
QD	8	3	0.131	0.125	8.37	2.092

*Supported by the Dean of Natural Sciences, Duke University

[#]smikhail@fel.duke.edu

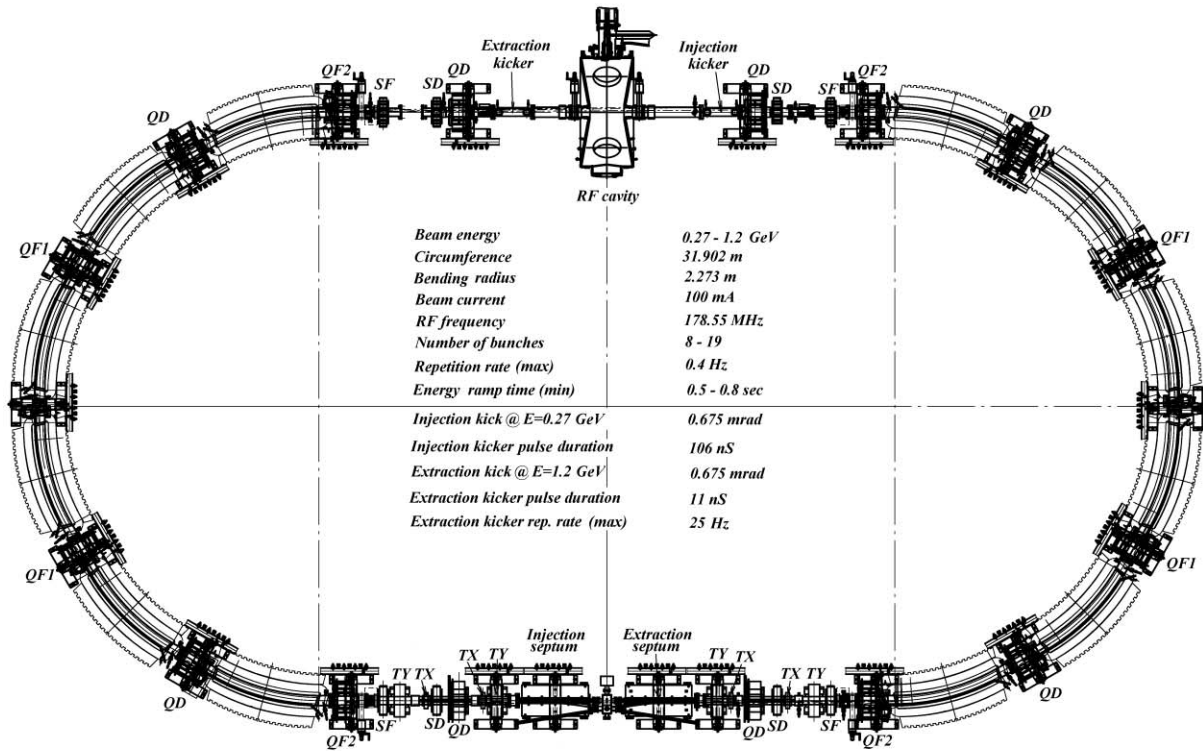

Figure 2: Layout and parameters of the Booster synchrotron

types of cores. The coils have the same shape but different number of turns (10, 7 and 3 for QF1, QF2 and QD respectively). The cores are the same in cross section and different in length (see Table 1). Besides of the vertical orbit correction coils (120 turns per pole, $I_{max}=6$ A) each quad also has gradient correction of up to $\Delta G/G_{max}=3.5\%$ for QF1 (40 turns per pole, $I_{max}=6$ A).

The core of the quads is made of Stabocor 940-50A low carbon/low silicon laminated steel with 0.5 mm thick laminations. The poles are shimmed to minimize 2D harmonic contents to be within $|b_n/b_2| < \pm 5 \times 10^{-5}$ for $n=6, 10, 14,$ and 18 at $R_n=2.4$ cm for any current up to $I=700$ A. A comprehensive end chamfer, optimized for the minimum integral harmonic content ($|\int b_n ds / \int b_2 ds| < \pm 3.6 \times 10^{-4}$, $n=6, 10, 14,$ and $18,$ at $R_n=2.4$ cm, for the quads of all types at any current up to $I=700$ A), also provides against 3D edge saturation during the fast ramp of current.

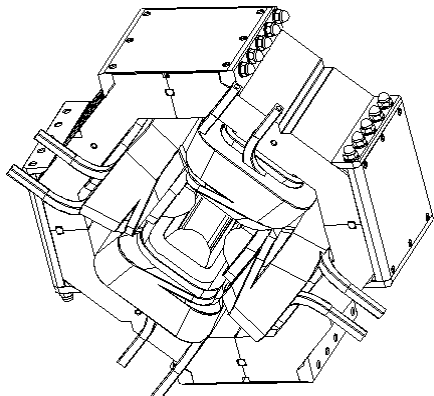

Figure 3: General view of QF1 quadrupole.

The bending dipoles have maximum field $B_{max}=1.76$ T at $E=1.2$ GeV in 27 mm gap and effective magnetic length $L_{eff}=1.19$ m. Each dipole has a trim coil capable of correction up to $\Delta B/B_{max}=2\%$ (60 turns per pole, $I_{max}=6$ A). For the end chamfers we accepted the shape developed for a dipole designed for 10 Hz operation cycle [3]. To fabricate the dipole cores we use 1 mm thick laminations of Stabocor 1500-100SG low carbon steel.

Stabocor steel is produced with a layer of glue on the sheets. To fabricate the parts of the core for both quads and dipoles their laminations are stacked in fixtures under specific pressure and then baked out. This makes the core practically solid, so that its parts may be machined, drilled, etc. The stacking factor for the magnetic simulations was assumed to be 0.98.

The other magnetic elements, such as septum magnets, sextupoles and trim dipoles are solid, their capability of fast field ramping is tested. We re-use existing sextupoles ($D=60$ mm) and weak dipole trims (72 mm gap).

Simulations and optimization for all the magnetic elements of the Booster have been done with the use of MERMAID 3D code [4].

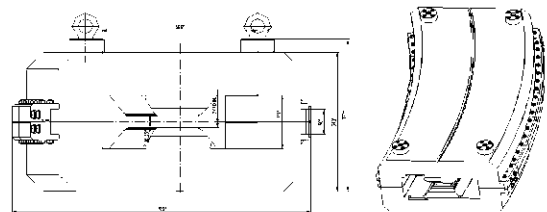

Figure 4: General view of the Booster dipole (core).

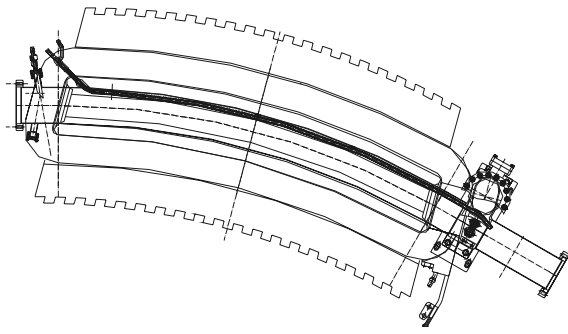

Figure 5: Arc periodic vacuum chamber (dipole & quad).

VACUUM SYSTEM AND KICKERS

The Booster has a stainless steel vacuum chamber. The arc chamber consists of 6 identical pieces (dipole & quad chambers). The dipole part of that periodic piece (Fig.5) is fabricated of 3" OD pipe with 0.049" thick wall. Stay clear area in the dipole is an ellipse of 107×24.5 mm.

Each periodic piece of the arc chamber accommodates a vacuum pump. In the arcs we install 6 NMD-0.1 (100 l/sec) and 6 PVIG-100/160 Russian ion getter pumps [5]. The latter are equipped with a TSP module. We also install nine 20 l/sec Varian pumps in the straight sections.

The calculations of the vacuum pressure distribution along the Booster ring showed that at injection $E=0.27$ GeV, 100 mA beam current, initially we can expect maximum pressure $\sim 1.5\text{-}2 \times 10^{-6}$, and after few weeks of SR cleaning it will drop down to $\sim 2 \times 10^{-9}$. The corresponding life time determined by the scattering on the residual gas initially may be expected as low as 4-5 sec, however after the SR cleaning it should increase up to 50 min.

One of the most challenging part of the Booster project is the single bunch extraction kicker with 11 nS pulse duration. The prototype of such a kicker has been fabricated and successfully tested, the design of real kickers is finished. Fig.6 plots their cross section. The use of novel pseudo-spark thyatron type commutators for the

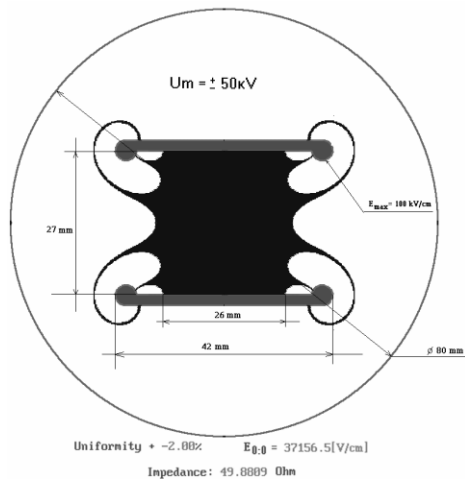

Figure 6: Extraction kicker for the Booster. Blue color shows 2 % homogeneity region. Vacuum pipe OD=80 mm.

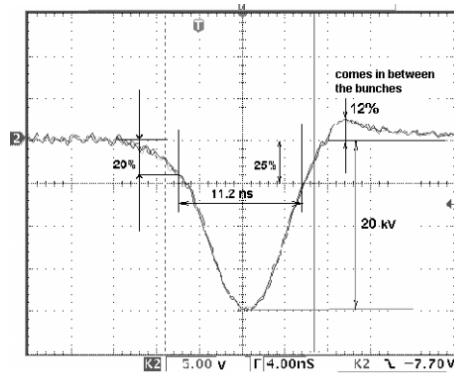

Figure 7: Extraction kicker pulse obtained with the use of fast pseudo-spark commutators (thyatrons)

kicker drivers is suggested instead of spark gaps commonly used for the very short pulses. The pseudo-spark commutators easily cover the entire voltage range required for the energy range 0.27-1.2 GeV. Fig. 7 shows the pulse shape measured on the kicker driven by the pseudo-spark commutators.

CONCLUSIONS

The design of the magnetic elements and the arc vacuum chamber of the Booster is finished and their fabrication started. Design of the vacuum chamber for the straight sections and design of the magnet supports with cooling pipes are to be finalized. Existing RF system from the storage ring will be used for the Booster after replacement by new RF with HOM damping. The disassembly of that existing RF system and installation of the new one into the storage ring is planned for February – April 2003. Booster main power supply is recently under construction and testing. Magnetic elements will arrive to Duke along with the vacuum chambers, kickers and magnet supports in May 2004. We plan to start the installation of the Booster on Summer – Fall 2004 and commission it during first half of 2005. The entire project, including modification of the north straight section of the storage ring for the injection from the booster, installation and commissioning of new linac-to-booster and booster-to-ring transfer lines, shall be completed in 2005 – 2006.

REFERENCES

- [1] S.F.Mikhailov, V.N.Litvinenko, P.Morcombe, G.Swift, N.A.Vinokurov, N.G.Gavrilov, Yu.G.Matveev, D.A.Shvedov, "Project of Booster Synchrotron for Duke FEL storage ring", Proc. of the 2001 Part. Acc. Conf., Chicago, 2001, p. 3525-3527.
- [2] S.Mikhailov, "Challenges for magnetic design of a compact Booster fed by single power supply", this proceedings.
- [3] Baryshev Yu.V., Dikansky N.S., Mikhailov S.F., et al., "LEB Dipole and Quadrupole Prototypes for SSC", Proc. of 1994 European particle accelerator conf. EPAC'94, London, 1994, Vol.3.- p.2223-2225.
- [4] Mermaid, the 2D/3D code for magnetic design, © A.N.Dubrovin, Novosibirsk, Russia.
- [5] <http://www.pryzma.ru>