

# MODIFICATION OF THE CORRECTION BIPOLAR POWER SUPPLY OF THE STORAGE RING

Chen-Yao Liu, Justin Chiou, Yuan-Chen Chien, Chang-Hor Kuo

National Synchrotron Radiation Research Center 101Hsin-Ann Rd, Science-Based Industrial Park, Hsinchu 30077, Taiwan, R.O.C.

## Abstract

To satisfy performance 1.5GeV beam current requirement in storage ring, the correction power supplies' output current ripple have to be low enough from 0Hz to 10 kHz. To suppress the output current ripple noise from 0Hz to 10 kHz, the correction power supplies must be modified from the normal frequency response to higher bandwidth to make the beam current performance in storage ring better. The controller gain of the correction power supplies is changed to detect the high frequency dynamic current ripple. A control gain modification scheme is presented here and the correction power supply with control gain modified have been proven to exhibit excellent output current ripple reduction from 0Hz to 10kHz. Results and measured performance will be presented in this paper.

## INTRODUCTION

The correction power supplies are responsible to control the correction magnets to steer the beam current to stay within the desired trajectory in the storage ring. Hence, the output current performance of the correction power supply will greatly influence the stability of the beam current. To future improve the beam current stability, the correction power supply's output performance is measured and investigated. It is found that the correction power supply's control gain has major contribution on the stability of the beam current.

Three major factors are evaluated for the performance of the correction bipolar power supply: [1] 0~10kHz of the current ripple response [2] long term stability of output current [3] Output noise current level. After the internal control gain is modified inside the correction bipolar power supply, not only the output current performance is satisfied, but also the low and high frequency output current response is good for various correction magnet loads of the storage ring.

This makes the control gain more adaptable to different loads. Most of all, when changing different correction magnets load to the correction power supply, the output current ripple of the correction bipolar power supply is under the specified specification. Compared with the old correction bipolar power supply, correction power supply's adaptability to various load is achieved by adjusting the control gain of the correction bipolar power supply. The correction bipolar power supply of NSRRC mentioned in this paper is designed by INVERPOWER Corporation. The block diagrams of the model SRR-220-25-IV as shown in the following Figure 1.

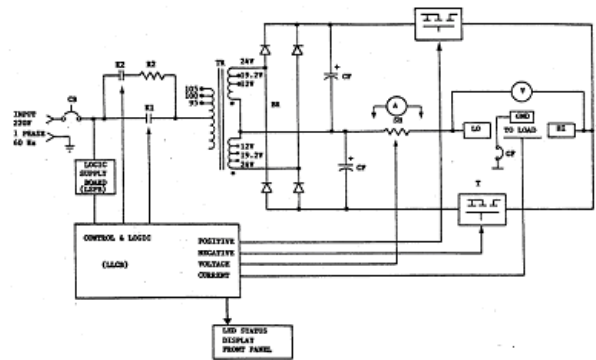

Figure 1: Model SRR-220-25-20-IV of the INVERPOWER power supply

## MODIFICATION PRINCIPLE

The major principle to modify the controller gain of the correction bipolar power supply, is to make the control gain of the current feedback loop meet the requirement of the output current ripple response of the correction bipolar power supply and the magnet both under the spec. To reduce the current ripple response, the correction bipolar power supply and the correction magnet is combined and regarded as one single system in our modification scheme. The control gain adjusted is the total feedback gain of the whole system.

For the adjustable function of the current feedback loop circuit, the characteristic of the current ripple response is specially paid attention to. The DANFYSIK DDCT 866 current measurement system and the HP 35670A dynamic signal analyzer are applied to analyze the total quick response of the current ripple response. The current ripple response measurement is shown as Figure 2.

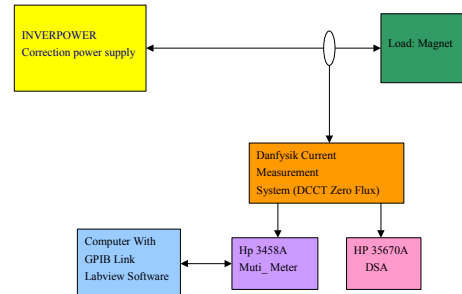

Figure 2: Block diagram of the current ripple response measurement system

Another important principle we certainly considered in the design is the stability of the feedback signal and the setting signal. A main circuit diagram of the control gain stage of the total correction bipolar power supply is shown as figure3.

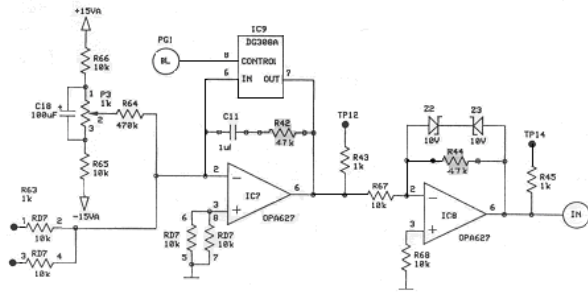

Figure 3: Main circuit diagram of the control gain stage of the correction bipolar power supply

For old requirement, the output current ripple variation has to be under 100ppm specification. For new control gain modification of the correction bipolar power supply, not only the adjusted correction power supply should meet the need of the old requirement, but also the current ripple from 0Hz to 10kHz is also controlled under 100ppm for the total ripple amount. To reach this purpose, the type and the structure of the controller was researched first for our designing the modified control gain step by step. Before we design the modified control gain. As shown and analyzed in Figure 3, the control stage of the correction bipolar power supply is of Proportional Integration Controller type (PI control), the error signal is first integrated and then amplified by a proportional gain stage. By adjusting the gains in both the integral and proportional stage. We can observe its effect on the output current ripple performance.

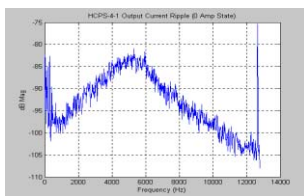

Figure 4: The current ripple increase from several hundred Hz to about 5kHz and then drops slowly as frequency increase.

Since the higher PI control gain of the correction bipolar power supply reacts with high speed, the fake signal produced by the parasitic noise in the circuit will make the feedback signal more sensitive. The resonance problem of the output signal will also contribute noise. To solve this problem, the control gain of the correction bipolar power supply is required to be low. The frequency response of the output current before gain adjustment is shown as Figure 4. It's observed that the current ripple

increase from several hundred Hz to about 5kHz and then drops slowly as frequency increase.

The reason for this peak is due to the high input impedance seen by the correction power supply. Figure 5 shows the frequency response of the impedance seen by the correction magnet power supply.

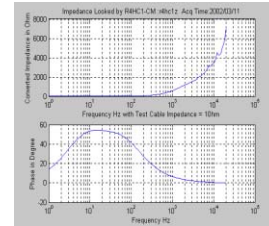

Figure 5: The frequency response of the impedance seen by the correction magnet power supply

The modification scheme is to lower the control gain to suppress high frequency output ripple but large enough to drive the correction magnet. The criteria to determine whether the control gain is too high is to observe the output current step response and check if there is overshoot occurs. The output current step response is shown in figure 6.

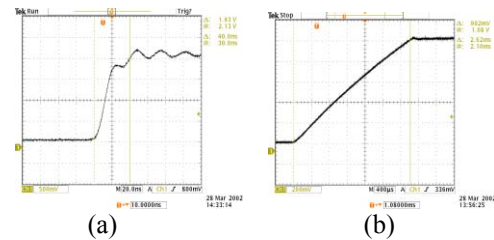

Figure 6: The setting signal (a) and current for step response of the correction bipolar power supply and magnet system (b)

## TESTING AND RESULT

After obtaining the parameter values of the controller from our lab, we load these experimental data into the correction bipolar power supplies of the storage ring. After careful testing of every correction bipolar power supply of the storage ring, it is relatively workable, reasonable and of good performance in the storage ring.

The testing data is collected and integrated for the reference in the future. The important parameter of the control gain of the correction bipolar power supplies in the figure 3 are listed below:

### PI Control Gain

**Old Control Gain: R42=47k ohm & R44=47K ohm**

**New Control Gain: R42=22k ohm & R44=15K ohm**

The measurement results are shown in Figure 7~8. It is shown that not only the current ripple of the high

frequency resonance is reduced, but the current ripples of 60Hz and 60Hz's harmonics are also reduced.

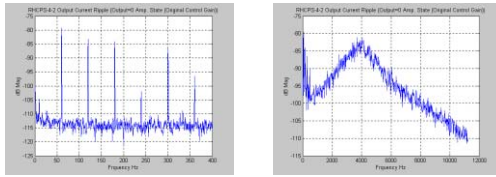

(Frequency: 0~400Hz) (Frequency: 0~10kHz)

Figure 7: The output current ripple of the correction bipolar power supplies (old control gain at 0Amp.)

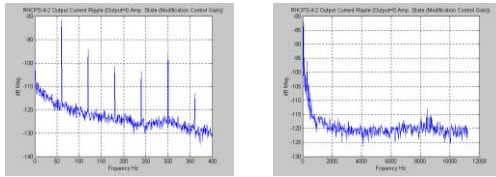

(Frequency: 0~400Hz) (Frequency: 0~10kHz)

Figure 8: The output current ripple of the correction bipolar power supplies (new control gain at 0Amp.)

The output noise current level is observed to be reduced from original -110dB to be about -120dB.

Next, the output current is set to 10 Amp to observe it's output current ripple performance. The measurement result is shown as Figure 9~10:

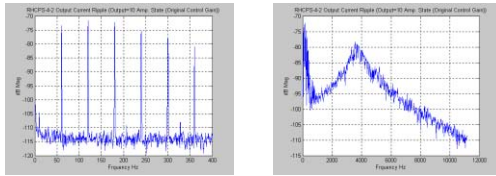

(Frequency: 0~400Hz) (Frequency: 0~10kHz)

Figure 9: The output current ripple of the correction bipolar power supply (old control gain at 10Amp.)

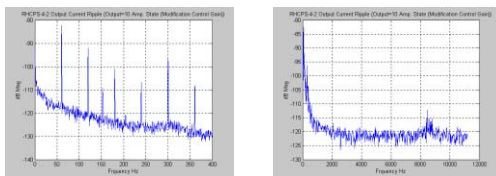

(Frequency: 0~400Hz) (Frequency: 0~10kHz)

Figure 10: The output current ripple of the correction bipolar power supply (new control gain at 10Amp.)

Although the considerable achievements on reducing the current ripple, it has to be considered whether or not the long-term stability of the output current will be effected by changing the control gain, the long-terms time domain results are shown as Figure 11. It is shown that the output performance is not effected by the new controller parameter.

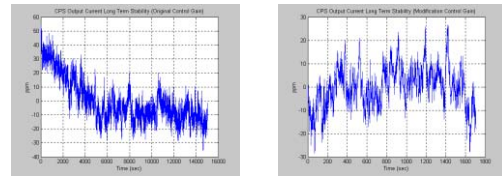

(Old control gain) (New control gain)

Figure 11: The long-term stability output current (10Amp. Output) testing of the correction bipolar power supply

## CONCLUSION

In the design and testing process, applying the technique of RC filter and  $\pi$  circuit to the output stage, the effect of this is limited since the high frequency current resonance problem is not solved. However, by adjusting the interior control gain of the correction bipolar power supplies, the output current ripple is greatly reduced. After modifying every correction bipolar power supply of the storage ring one by one and then putting all the correction bipolar power supplies back to the storage ring system, the performance of the beam current observed is found to be better. The beam current quality in NSRRC is greatly improved.

## REFERENCE

- [1] Benjamin C. Kuo, Automatic Control System, PRENTICE-HALL INTERNATIONAL, INC. Fifth Edition, 1987.
- [2] Join G.Kassakin, Martin F.Schlecht, George C, Verghes, Principles of Power Electronics, ADDISON -WESLEY Publishing Company, 1991.
- [3] Bipolar Linear Correction DC Power Supplies Model SRR-220-25-20-IV Operation Maintenance Manual.