

A NEW THERMIONIC RF ELECTRON GUN FOR SYNCHROTRON LIGHT SOURCES *

S.V. Kutsaev¹, R. Agustsson¹, J. Hartzell¹, A. Murokh¹, A. Nassiri², E. Savin^{1,3}, A.V. Smirnov¹, A.Yu. Smirnov¹, Y. Sun², A. Verma¹, G. Waldschmidt², and A. Zholents²

¹RadiaBeam Systems, LLC, Santa Monica, CA, 90404, USA

²Argonne National Laboratory, Lemont, IL, 60439, USA

³also at National Research Nuclear University « MPhI », Moscow, Russia

Abstract

A thermionic RF gun is a compact and efficient source of electrons used in many practical applications. RadiaBeam Systems and the Advanced Photon Source at Argonne National Laboratory collaborate in developing of a reliable and robust thermionic RF gun for synchrotron light sources which would offer substantial improvements over existing thermionic RF guns and allow stable operation with up to 1A of beam peak current at a 100 Hz pulse repetition rate and a 1.5 μ s RF pulse length. In this paper, we discuss the electromagnetic and engineering design of the cavity and report the progress towards high power tests of the cathode assembly of the new gun.

INTRODUCTION

Electron guns are used in electron microscopes, electron beam welders, and as sources for particle accelerators. Thermionic RF electron guns were developed at SLAC/SSRL for the Stanford Positron Electron Accelerating Ring (SPEAR) Project [1]. Conventional RF guns can offer high average beam current, which is necessary for synchrotron light and THz radiation sources facilities, as well as for industrial accelerators. Most of the light sources worldwide are storage ring based, and thus rely on thermionic guns for their operation. Unfortunately, they have decades-old thermionic RF gun technology, and it is due for an upgrade.

The current RF gun is a 1.6-cell side-coupled structure, operating at 2856 MHz frequency. Typically, the RF gun is powered with \sim 1.5 MW pulsed power but can sustain up to 7 MW via an end-coupled waveguide. The cathode used is a tungsten dispenser cathode with a diameter of 6 mm. The gun can produce peak beam kinetic energies of up to 4.5 MeV and peak macro pulse currents of up to 1.3 A. Practical operating RF pulse parameters are \sim 1 μ s at a repetition rate of \sim 15 Hz. More details of gun parameters may be found in [2].

Recently, RadiaBeam Technologies has developed and demonstrated a compact source of narrow bandwidth free space THz radiation [3] using the actual APS gun at the Injector Test Stand (ITS) facility. A thermionic injector generates an electron beam, which is compressed in an alpha magnet and propagated through a few cm-long corrugated pipe radiator. A prototype system was

commissioned at Argonne National Laboratory, and demonstrated a strong signal ($>$ 100 kW peak power), at 500 μ m wavelength, in \sim 5% bandwidth. While the initial commissioning of this THz source has so far been very encouraging, pushing the system performance envelope beyond 2 THz requires an update of the RF gun performance.

Given the immediate requirements of these two applications, RadiaBeam in collaboration with APS are developing the new reliable and robust thermionic RF gun with the parameters specified in Table 1.

Table 1: Design Parameters of the RF Gun

Parameter	Value
Operating frequency	2856 MHz
Output energy	up to 3 MeV
Accelerated current	up to 1A
RF power	5 MW
Repetition rate	up to 100 Hz

ELECTROMAGNETIC DESIGN

Conventional thermionic RF gun design implements a side coupling cell [4]. This cell is required to tune the field ratio between main cells and to increase frequency mode separation in the cavity. However, such design has several significant drawbacks. First, an additional cell complicates the engineering design and fabrication process. Second, it breaks the symmetry of the structure. Finally, due to the sharp edges in the area where accelerating cells connect to the coupling cell, the peak surface magnetic field can be strong in this area. Strong magnetic field increases the pulsed heating temperature gradient and limits the performance of the RF gun both by reducing the maximum gradient and by limiting the pulse length [5].

In our design, we propose to remove the coupling cell and add magnetic coupling holes to the iris between the cells to provide required mode separation and similar dimensional sensitivity without any change to the electrodes shape (see Figure 1). In this case, the structure will operate in π -mode, and magnetic field will provide the coupling. Pin tuners in each cell will allow the tuning of the field ratio. The magnetic coupling holes cause the longitudinal field asymmetry in the full cell. To compensate this effect, we reduced the blending radius of one side of the cavity. We kept the original design of the electrodes, so the beam quality remains the same as in the existing APS gun.

* This work is supported by the U.S. Department of Energy, Office of Basic Energy Science, under contract DE-SC0015191 and contract No. DE-AC02-06CH11357

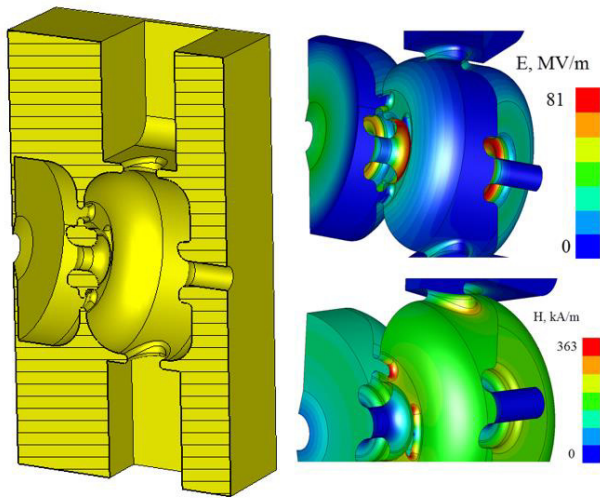

Figure 1: Left: pi-mode structure design, right: electric (top) and magnetic (bottom) fields distribution.

Table 2 summarized the parameters of the existing and the new designs. We increased the model separation to a reasonable number of 22 MHz which is roughly half of a bandwidth of the klystron. Peak surface magnetic fields are reduced by ~50%, sharp edges are eliminated, and magnetic coupling holes' fabrication is controllable. The maximum operating pulse length is increased to 3 μ s. The symmetrical waveguide has been added to the design to increase the field symmetry: the transverse kick is two orders lower than for the $\pi/2$ -mode design.

Table 2: Comparison of $\pi/2$ and π -mode RF Gun Parameters

Structure	$\pi/2$	π
Maximum on-axis field E_{full} , MV/m	70	70
Mode separation, MHz	48	22
Shunt impedance ($\beta=0.999$), $M\Omega/m$	62.5	60
Peak surface E-field, MV/m	145	142
Max pulse length, μ s	1.5	3.1

CATHODE ASSEMBLY DESIGN

The cathode backplate is one of the most critical parts of the thermionic gun. It must provide a thermal isolation of the hot cathode to exclude the field distortions due to the plate deformation. Also, the electrical contact of the cathode and the back plate should be provided, so that RF fields do not get into the gap between the cathode and the back plate and therefore damage the structure.

In our initial analysis of the present injector experience, the vulnerability of a cathode mounting assembly was identified as the highest risk factor. Hence, the critical path of the gun design includes a redesign of the cavity back plate, RF contact, and stub tuners, and high power tests of the assembly, using dummy cavity with an interchangeable cathode assembly.

We have designed the indirect cooling scheme to provide active cooling of a removable gun backplate, along with thermal sensors to monitor the backplate

temperature and direct water cooling of the main coupler body, as shown in Fig. 2. The indirectly cooled detachable backplate was chosen it permitted flexibility of back plate modifications and experimentation. Thermionic gun integration involved mounting directly to the cathode plate to allow the best alignment of the gun on the backplate.

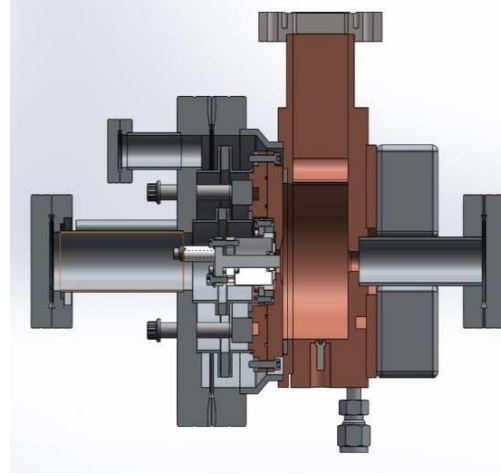

Figure 2: Engineering design of the cathode assembly test stand with indirectly cooled detachable back plate

For the electrical coupling and thermal decoupling, an RF spring approach was considered where a helical toroid spring would be integrated into the cathode plate. Later, this idea was dropped based on the simulations as discussed below. Upon experimental validation, the final gun design may opt to utilize a non-removable backplate.

At this stage, we have chosen to use the Heatwave 61280 commercial cathode for its proven operation history and availability. Depending on the results of the cathode assembly high power tests we will work with Heatwave and ANL to upgrade the cathode design to improve its reliability.

THERMAL ANALYSIS

The model of the cathode backplate and test cell assembly for the high power test stand was simulated in CST Multiphysics Studio to estimate the temperature rise on the plate and the springs that connect it with the cathode. To achieve the same maximum on-axis field in the test stand cavity as in the actual 1.6 cells gun, ~1.0 MW peak input power is required to be input into the dummy cell.

Three types of heat load were assumed in simulations: RF losses, losses from the heated cathode through the spring and radiation losses from the cathode. Temperature distribution in cathode assembly from combined losses is shown in Figure 3.

One of the major improvements of the design is thickening the knife edge of the cathode backplate that improved structural stability significantly. ASTRA simulations with 1D longitudinal field distribution from CST Studio was done for three variants of cathode mount knife edges for the particles injected thermionically during 350 ps. We concluded that the difference in

emittance and capture for different edge thicknesses is relatively negligible: emittances for truncated bunches show insignificant monotonous growth, especially for 1cm long bunch head. The concentration of particles within the 2.4mm short tip even increases for thicker knife edges.

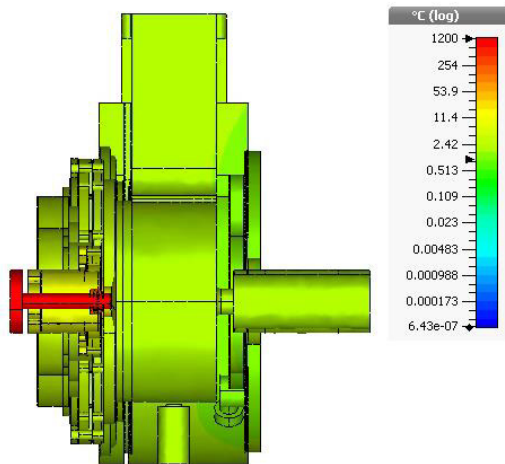

Figure 3: Temperature distribution in cathode assembly

FABRICATION PROGRESS

All the components required for the cathode cooling braze were machined, checked dimensions per print, fitment checks done, cleaned, brazed and leak checked. Necessary parts for the welding has been machined, fitment checks done, cleaned and sent out for welding. Braze as well as post braze machining sequence finalized. Coupler body, tuning studs, shim, water fittings, CF flange, tube, cooling cover modeling and drawings done, and will be in the fabrication soon.

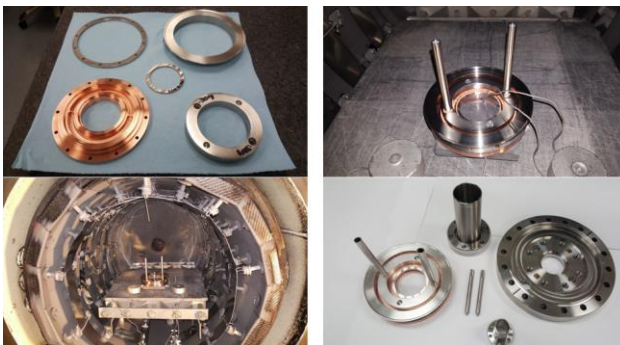

Figure 4: Various parts manufactured and brazed including cooling assembly piece parts (upper left), brazing assembly setup in the oven (upper right and lower left) and parts sent to welded bellows manufacturing vendor (lower right).

Machined parts (Fig.4) have been dealt with utmost care to prevent scratches, dings or dents and handled using gloves all the times. All the parts of the structure are treated as UHV. Cleaning of all the parts using mild citric acid process will be done as per RBT cleaning guidelines except the RF coupler volume facing parts, which will be etched per the standard SLAC etching formulary.

2: Photon Sources and Electron Accelerators

T02 - Electron Sources

HIGH POWER TEST STAND

The high power RF system for this experiment is based on a CPI VKS-8262F2 S-band klystron. The tube is capable of 5 MW peak power, and 36 kW average power. It is driven by a ScandiNova K1-P solid-state modulator (see Fig. 5). A Microwave Amps Ltd. model AMS10-2.85S-52R provides the low-level RF source and preamp for the input of the klystron. For this experiment, we will run the klystron at a reduced power to provide the power level necessary for testing the gun cavity. All components are in-house and have been tested to verify performance requirements.

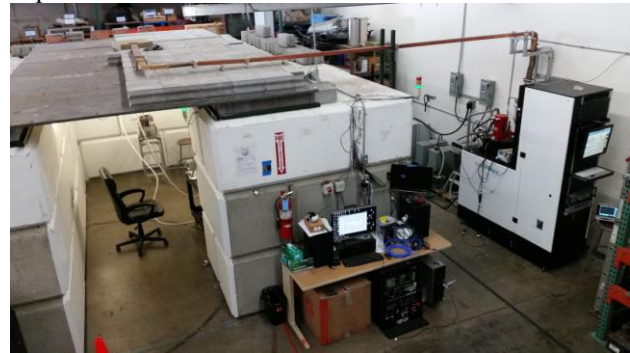

Figure 5: RadiaBeam radiation bunker. CPI klystron and magnetron modulator are on the right-hand side.

The klystron and modulator have been fully assembled and tested into a dummy load. We installed the interlocks to protect the system against various modes of failure (loss of water, loss of solenoid power, etc) as well as interlocks to prevent the system from pulsing without the bunker door being closed to protect personnel. We have achieved full power operation at a reduced rep rate.

SUMMARY

The electromagnetic design of a new a thermionic RF gun for synchrotron light sources was done by collaboration work of RadiaBeam Systems and Argonne National Laboratory. We proposed to use a pi-mode design with magnetic coupling holes that can operate at longer pulses and has a negligible dipole and quadrupole components. We have done the mechanical design of the critical element of the gun - cathode backplate. We designed the high power test stand to prove the proposed concept, purchased and fabricated most of the parts. When all parts are available, we will perform high power tests and evaluate the reliability and the robustness of the current cathode assembly design. Depending on the high power test results, we will consider improving the cathode design for the commercial gun.

ACKNOWLEDGMENTS

We would like to thank V. Dolgashev from SLAC for valuable feedback on accelerating structure design.

REFERENCES

- [1] E. Tanabe *et al.*, "A 2-MeV Microwave Thermionic Gun", SLAC-PUB-50.54.
- [2] M. Borland, "Cavity Design and Beam Simulations for the APS RF Gun", APS Light Source Note, LS-186, pp.15.
- [3] A. V. Smirnov *et al.*, "Observation of a variable sub-THz radiation driven by a low energy electron beam from a thermionic RF electron gun", *Phys. Rev. ST AB* 18, 090703, 2015.
- [4] K. Beczek *et al.*, A rational approach to thermionic gun design, *Proc. PAC01*, 18-22 June 2001, Chicago, Illinois.
- [5] V. A. Dolgashev, "High Magnetic Fields in Couplers of X-band Accelerating Structures". *Proc. PAC03*, 12-16 May 2003, Portland, Oregon.