

LINAC LU-20 AS INJECTOR OF NUCLOTRON

Govorov A.N., Kalagin I.V., Kovalenko A.D.,
 Monchinsky V.A., Ovsyannikov V.P., Pilipenko U.K., Popov V.A., Salimov E. H., Volkov V.I.
 RU-141980 Dubna, Joint Institute for Nuclear Research, LHE, Moscow reg., Russia

1. Abstract

The linac LU-20 created as an injector of Synchrophasotron and Nuclotron is described. Tables of main parameters and beam intensities are included. The functional diagram of LU-20 is shown. Injection channels, diagnostic and control systems are described also. The scheme of beam transport line is also provided.

2. Introduction

Nuclotron injector at present time is the linac LU-20, which was built in 1974 as a proton injector for Synchrophasotron with output energy of 20MeV [1]. In fact from the beginning it was used as a proton accelerator and as an accelerator of light element nuclei and ions at the second drift ratio with output energy of 5MeV/nucleon. Nuclei of such elements as deuterium and helium (the duoplasmatron was used as a nucleus source), ${}^6\text{Li}^{3+}$, ${}^7\text{Li}^{3+}$, ${}^{11}\text{B}^{5+}$, ${}^{12}\text{C}^{4+}$, ${}^{14}\text{N}^{5+}$, ${}^{16}\text{O}^{6+}$, ${}^{19}\text{F}^{7+}$, ${}^{24}\text{Mg}^{10+}$, ${}^{28}\text{Si}^{11+}$ (the laser ion source[2]), ${}^{20}\text{Ne}^{10+}$, ${}^{22}\text{Ne}^{10+}$, ${}^{32}\text{S}^{14+}$, ${}^{40}\text{Ar}^{16+}$, ${}^{84}\text{Kr}^{34+}$ (electron beam ion sources "Krimon"[3] and "Krimon-S"[4]) were accelerated. Polarized deuteron beams were accelerated using cryogenic source POLARIS[5].

So, the spectrum of accelerated in LU-20 nuclei and ions is provided by four ion sources:

- the duoplasmatron;
- the laser ion source (LIS);
- EBIS KRION-S;
- the polarized deuteron source POLARIS;

Accelerated beam intensities are shown in **Table 1**.

In 1993 the Nuclotron was built in Dubna. Since then LU-20 has been also used as the Nuclotron injector.

3. Pre-injector

The pre-injector is powered by 700 kV pulse transformer. The low voltage winding is fed by a form line with distributed parameters. The maximum duration of a HV pulse is 600 μs . The stability of high voltage is within $\pm 5 \cdot 10^{-3}$. The accelerating tube consists of 56 aluminium diaphragms separated by porcelain rings. The diaphragms are connected to a high voltage water divider. A grid with an aperture diameter of 220 mm is installed at the 28-th diaphragm. The ion sources are mounted on a HV terminal

of the accelerating tube and have ion optic systems for initial forming of beams.

Table 1

Accelerated beam intensities

Particle type	Intensity at the output of LU-20	Source	Pulse duration (μs)
p	$1 \cdot 10^{14}$	Duoplasmatron	500
d	$3 \cdot 10^{13}$	Duoplasmatron	500
d \uparrow	$3 \cdot 10^{10}$	POLARIS	500
α	$6 \cdot 10^{12}$	Duoplasmatron	500
${}^6\text{Li}^{3+}$	$1 \cdot 10^9$	LIS	30
${}^7\text{Li}^{3+}$	$5 \cdot 10^{10}$	LIS	30
${}^{12}\text{C}^{6+*}$	$2 \cdot 10^{10}$	LIS	20
${}^{16}\text{O}^{8+*}$	$3 \cdot 10^9$	LIS	10
${}^{19}\text{F}^{9+*}$	$2 \cdot 10^9$	LIS	10
${}^{24}\text{Mg}^{12+*}$	$1 \cdot 10^9$	LIS	5
${}^{28}\text{Si}^{14+*}$	$1 \cdot 10^8$	LIS	5
${}^{32}\text{S}^{14+}$	$2 \cdot 10^8$	KRION-S	100
${}^{40}\text{Ar}^{16+}$	$2 \cdot 10^6$	KRION-S	100
${}^{84}\text{Kr}^{34+}$	$1 \cdot 10^5$	KRION-S	100

Note: * - after stripper

The ion sources on the high voltage terminal are powered by a generator separated by an insulating driving shaft. It has output power of 10 kW.

The pre-injector tube is pumped by a vapour oil pump with a trap. The pump has the total performance of 5000 l/sec. The tube is connected to the linac cavity by a vacuum line on which an axial symmetric matching lens, a buncher, a double magnetic corrector, a beam current transformer and a Faraday cylinder are placed.

The sources are controlled via an optic fiber line from the LU-20 control room.

4. The accelerating-focusing system of LU-20

The linac LU-20 is an accelerator of Alvarez type. It has the following main parameters (see **Table 2**).

Drift tubes are fastened inside the resonator using two rods and contain quadrupole lenses working in continuous mode. Precise tuning of field strength distribution along the resonator is made by disks placed at the drift tubes.

While working at the second drift ratio field distribution is changed by a bottom tuner, that allows to create field subsiding to the resonator end.

To increase the intensity of accelerated deuterium and helium nuclei, the injection is made into the 5th gap.

The voltage on the accelerating tube of the preaccelerator is increased in two times, that results in emittance improvement of the injected beam [6].

Table 2
Main parameters of LU-20

injection energy: protons		600 keV
injection energy: ions	$2\beta\lambda$	150 keV/nuc
output energy: protons		20 MeV
output energy: ions	$2\beta\lambda$	5 MeV/nuc
working frequency	F	145 MHz
resonator diameter	D	1.4 m
resonator length	L	14.4 m
number of drift tubes	N	57 + 2 semitubes
resonator quality	Q	40000
synchronous phase	ϕ_s	- 31.5°
focusing system	FODO	
quadrupole lens gradients	H'	(58.4 - 7.4) T/m
characteristic parameter	$\cos\mu$	0.6
aperture	2a	17;20;25 mm
acceptance	A	$220 \pi \bullet \text{mm} \bullet \text{mrad}$
energy dispersion with debuncher	$\Delta P/P_0$	$\pm 0.15 \%$
min. charge to mass ratio	Z/A	1/3

To reach this a solid metal wall is installed at the 4th drift tube, and quadrupole lenses of the first four accelerating periods are used for beam transportation. While accelerating ions with $Z/A < 0.5$ the beam is injected into the first gap. It was experimentally proved that the highest field strength reached without breakdowns allows to accelerate ions with $Z/A \geq 1/3$. The flat peak duration of RF-pulse equals to $\approx 30 \mu\text{s}$. The reached field strength values and maximum allowed gradients in the existing lenses are far from the required values. So accelerating of ions with $Z/A = 1/3$ is not effective.

At the output of the linac a carbon stripper with the average mass to square ratio $\approx 60 \mu\text{cm}^2$ is installed. Usage of the stripper for ions with energy of 5MeV/nuc is useful only for light nuclei up to Ar.

To increase accelerating beam intensities a buncher is installed at the input of LU-20 and a debuncher is used to decrease dispersion of beams injected into Nuclotron.

5. RF-power system

where PC is Phase Changer, A1, A2 are generators (1st and 2nd channels of "Rodonit"), IA is intermediate amplifier, L is 75 Ohm load, PB is phase bridge, A4 is generator of debuncher, DG is defining generator.

The RF-power system of LU-20 is intended to excite in the resonator, buncher and debuncher powerful electromagnetic fields, which are stable in frequency, amplitude and phase. The peculiarity of the RF-power system consists in the wide range of required exciting power, because LU-20 can accelerate ions with Z/A equal to 0.3...1. The exciting power can vary from 2MW on accelerating of nuclei with Z/A of 0.5 up to 5.5MW on accelerating of ions

with Z/A of 0.3. In Fig. 1 a functional diagram of the RF-power system necessary to receive maximum output power in the resonators is shown. In this case the resonator is excited by two autogenerators "Rodonit". Both generators have positive feedback loop through the resonator. To excite main mode TM_{010} suppression of the highest modes TM_{011} and TM_{012} is made. To do so, power is entered via exciting loop, which is placed at the middle of the resonator. Besides, positive feedback loops are located at places where the highest modes are absent, i.e. at the lengths equal to 1/4, 1/2 and 3/4 of the resonator length.

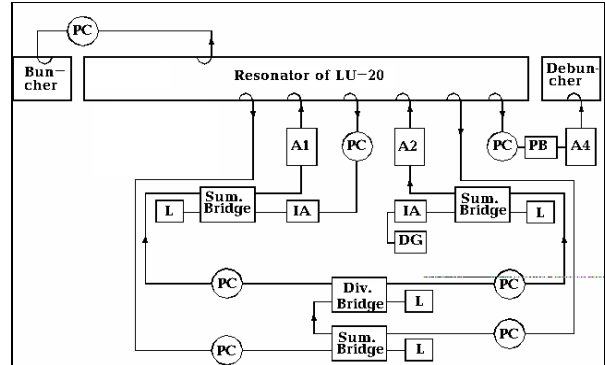

Fig. 1

One of the problems of resonator excitation is resonance RF-discharge multiplication. The most probable place of resonance RF-discharge multiplication appearance is the initial part of the resonator. To suppress it an additional positive feedback system entered at the input of the main generator is used. This system consists of a standalone generator with low output power (up to 500W), a phase changer and a connection loop. When the resonance RF-discharge multiplication appears by some reasons, the main positive feedback signal level becomes too low to excite the powerful generators. The extra positive feedback system doesn't depend on resonance RF-discharge multiplication strongly, because its connection loop is located at the end of the resonator. So this system provides RF-field excitation.

The buncher is fed from the LU-20 main resonator by the connection loop via the cable and the phase changer. The buncher requires about $\approx 25 \text{kW}$ of RF-power.

To feed the debuncher a standalone RF-amplifier with output power of $\approx 250 \text{kW}$ is used.

To suppress resonance RF-discharge, in the gaps of buncher and debuncher resonator electrodes are installed with negative voltage on them.

6. Beam transport channel

LU-20 has two beam transport lines. The first one is intended to inject beams into Synchrophasotron and the second one is intended to inject beams into Nuclotron. The initial part of the channel is common to Synchrophasotron and Nuclotron. This part consists of the first triplet of quadrupole lenses, an additional lens and dipole bend

magnet IBM, which turns a beam in vertical by 15.6°. During injection in Synchrophasotron IBM is off. The beam transport channel with installed diagnostic and control systems are shown in Fig. 2.

The channel of injection into Nuclotron [7] was designed to provide compatibility with the channel of injection into Synchrophasotron. Besides, it should be taken into account, that median plane of Nuclotron is 3760 mm below than the LU-20 axis and beam injection is made vertically. The channel allows to make achromatic injection on the median plane and to position a beam on Nuclotron orbit. In horizontal plane the channel coincides beam axis with linear part of the Nuclotron axis. The channel also coincides the beam dispersion.

To protect superconductive elements of Nuclotron from warming up, a deflector is placed in the channel. The deflector creates beam pulses with the required duration. The pulses have fronts of 100ns. Unused pulse part is adsorbed by an adsorber installed at the debuncher input.

Vacuum in the channel is provided by magnet-discharging pumps with total performance of 800 l/min. After magnet IBM a nitrogen trap is installed to separate general part of the channel having vapour oil pumping. It allows to obtain vacuum value of $\approx 5 \cdot 10^{-8}$ torr.

7. Diagnostic and control systems

In the beam transport line Faraday cylinders, transformers of current, collector current profilometers and scintillation observation stations are used as diagnostic and control elements.

To measure beam charge distribution a fully adsorbing spectrometer with silicon detectors is installed in the Synchrophasotron injection channel after IBM magnet. Moreover, another method is used to identify accelerated in LU-20 ions. In this case an analyzed beam passes through the stripper and then is analyzed using the bending magnet of

Synchrophasotron channel. This method can be applied to identify middle and heavy ion beams.

The transformers of current are used for high intensity beam measurements. Beam currents of ≤ 0.5 mA are measured by the Faraday cylinders having maximum sensitivity of $\approx 10^7$ elementary charges/pulse. High intensity beam ($\geq 10^9$ elem. charges/pulse) profiles are obtained using the collector current profilometers. There are two scintillation observation stations with maximum sensitivity of $\approx 10^7$ elem. charges/pulse to measure different intensity beams. Each station has a set of five targets. The targets are made as grids to estimate beam parameters.

Low intensity beams are observed using electron-optic amplifiers.

All parameters of the linac (the potential in the pre-injector, RF-field in the linac, buncher, debuncher resonators, currents in the drift tube lenses, currents in the magnet elements of the transport channel and so on) are processed by computers and displayed on the linac control room monitors.

8. References

- [1] Y.D. Beznogikh et al., JINR Preprint 9-9120, Dubna, (1975).
- [2] A.I. Govorov, I.V. Kalagin, V.A. Monchinsky et al., Proc. of the 1994 Int. Linac Conf., Tsukuba, Japan, V1, p.372 (1994).
- [3] V.P. Vadeev, E.D. Donets, JINR Preprint P7-10823, Dubna, (1977).
- [4] V.P. Ovsyannikov, Proc. of the 1994 Int. Linac Conf., Tsukuba, Japan, V1, p.384 (1994).
- [5] A.A. Belushkina and others, 1981, "Proceedings of the 7th All-Soviet conference on charged particle accelerators", v.2, pp. 114-117.
- [6] Y.D. Beznogikh et al., JINR Preprint 9-9592, Dubna, (1976).
- [7] Y.D. Beznogikh et al., JINR Preprint 9-90-107, Dubna, (1990).

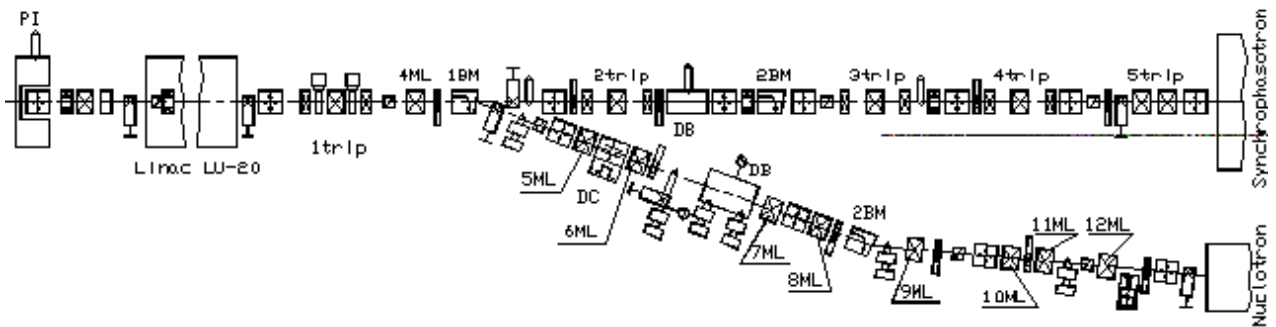

Fig. 2

The beam transport channels

where PI is the pre-injector, BM the bend magnets, ML the magnet lenses, Trip the triplets, DB the debuncher