

OTR MONITOR FOR ATF LINAC

T. Naito, H. Hayano, S. Kashiwagi*, S. Takeda and J. Urakawa

KEK, National Laboratory for High Energy Physics
Oho 1-1, Tsukuba, Ibaraki, 305 Japan

*The Graduate University for Advanced Studies
Oho 1-1, Tsukuba, Ibaraki, 305 Japan

Abstract

A bunch by bunch profile monitor system using optical transition radiation (OTR) is developed for an Accelerator Test Facility (ATF) linac. The ATF consists of a 1.5 GeV linac and a damping ring is now under constructing in KEK. The linac accelerates a multi-bunch beam (20 bunches/pulse, 2×10^{10} electrons/bunch, 2.8 ns spacing between bunches). The energy spread of the multi-bunch caused by the transient beam loading is a significant problem for the injection of the damping ring. The linac has energy compensation system to compensate the energy spread of the multi-bunch. In order to measure the energy and energy spread of each bunch, we developed the monitor system. The system and the measurement result are reported.

Introduction

The Accelerator Test Facility (ATF) consists of a 1.5 GeV linac and a damping ring (DR) is now under constructing in KEK. The DR is designed to realize a small vertical emittance, $\epsilon_{ny} = \sim 30$ nm, for future Linear Collider. The commissioning of the ATF linac had been started from November 1995 and the commissioning of the DR will be started in the end of this year. The linac accelerates multi-bunch beam. The beam has 20 bunches of 2×10^{10} electrons with 2.8 ns spacing. In order to reduce the energy spread of the multi-bunch beam, due to the transient beam loading, Energy Compensation System (ECS) were installed and the preliminary experiment was carried out [1].

The measurement system of the energy and the energy spread of each bunch is needed for tuning the ECS. The optical transition radiation (OTR) monitor was already developed for the 80 MeV injector section [2]. The OTR is emitted when the charged particles go through the interface which have different dielectric constants. The polished stain less steel was employed as the emitter for the OTR monitor. A fast gate camera (Hamamatsu C2925) is used for observed the bunch by bunch profile in the multi-bunch beam when apply the gate signal to each beam timing. This monitor could measure the beam emittance, energy and energy spread of each bunch at the 80 MeV injector section. The OTR monitor at 1.5 GeV section is designed and tested for the above purpose. The spot size limit of the OTR monitor according to $\sim \lambda/2$ [3]. At 1.5 GeV section, the spot size limit is 0.24 mm for 500nm wavelength. This value is assumed that is not so affected the beam size measurement. Recently, the spot size limit was discussed and tested [4, 5].

OTR monitor system

The monitor setup is shown in Fig. 1. The OTR monitor is located at the downstream of the first bending magnet and the first quadrupole magnet of the beam transport line. The position deviation at the place is calculated by

$$x = \frac{E}{E'} h,$$

where h is the dispersion function.

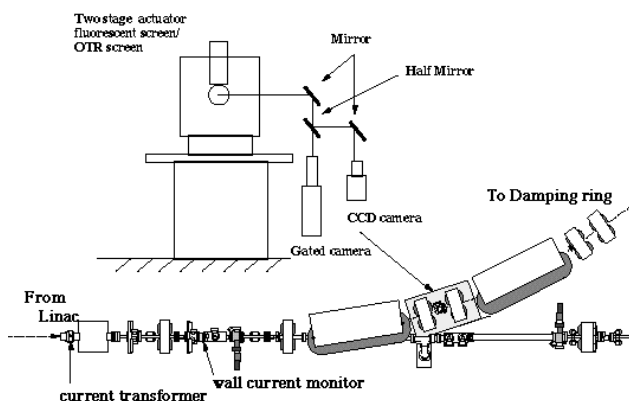

Fig. 1. Location of the OTR monitor for ATF linac.

The actuator system has two screens and can be stopped each screen position at the beam line. One is fluorescent screen, the other is the OTR emitter made by polished stain less steel which has 1 mm thickness and $1/2$ flatness. The emitted light (fluorescent light/OTR) is reflected by a mirror to avoid the x-ray and fed to a gate camera and a CCD camera by a half mirror. The fluorescent light is observed by the CCD camera and the OTR is observed by the gate camera. Both profile by these monitors can compare each other.

Trigger control and video analyze system

The control system of the gate camera is shown in Fig. 2. The gate camera can observed the bunch by bunch beam profile when apply the appropriate gate width and timing. The timing signal is created from the beam trigger. The signal is delayed in 2.8 ns step and met to each beam timing by the delay module. The delay module makes delay by count the reference clock from start signal. The reference clock is synchronized to the accelerating frequency. The trigger jitter of the delay module is less than 10 ps. The fine delay C1097 (Hamamatsu) adjusts the gate timing to the center of the beam timing. The

pulse generator 8112A (H.P.) makes the gate width included offset of ~16.5 ns. The gate pulse of 3 ns is applied when the pulse with 19.5 ns pulse width is generated by the pulser. The 8112A and the C1097 are controlled by sub-control computer (PC) through GPIB.

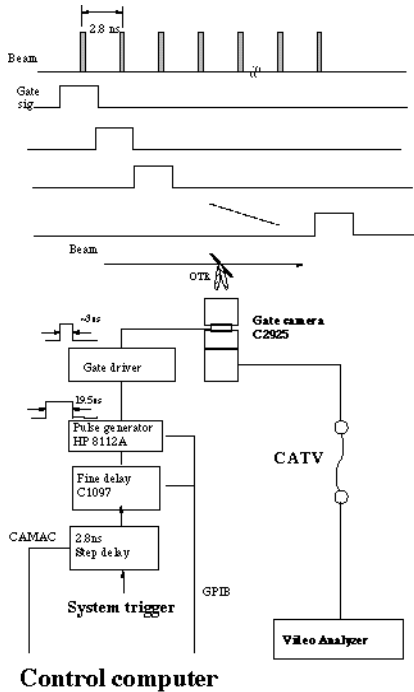

Fig. 2. Trigger system of the gate camera.

The video signal of the gate camera is fed to the operator room through CATV and analyzed by the video analyzer using a work station. The analyzer calculates x- and y-direction of the projection and the fwhm, the peak position, the peak value, etc., in real time. The automatic data acquisition system from Accelerator control computer (VAX VMS) is under development.

Gate characteristics

The characteristics of the gate camera is measured by using the beam signal. The gate timing is scanned with 250 ps step. The intensity of the profile is intensified and eliminated by the gate timing. The characteristics is plotted in Fig. 3. There is a dip between the previous bunch timing and the next one. This means that the gate camera is distinguishable the profile between the previous bunch and the next bunch. The appropriate gate timing is decided from this data.

ECS experiment

ECS system [6]

The ATF linac uses 18 accelerator structures of S-band frequency. 16 regular sections which uses 2856 MHz and two compensation sections which uses 2856±4.3 MHz. At the regular sections, the first bunch feel the maximum field of the

cavity and the following bunches feel the reduced field caused the transient beam loading effect. At the compensation sections, each bunch feel the field of the different phase of the cavity. The phases of compensation sections are synchronized the beam from decelerate phase (first bunch) toward to accelerate phase (20 the bunch). The compensation effect is adjusted by changing the power of compensation section and the relative phase of regular sections and compensation sections.

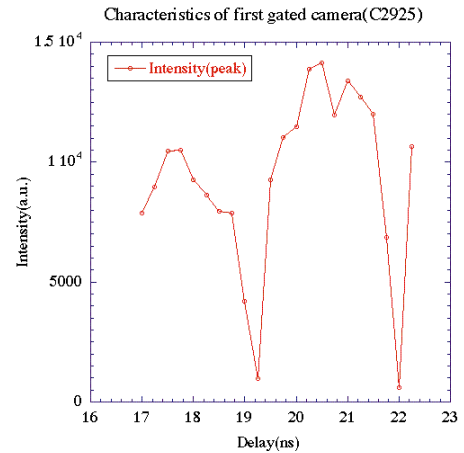

Fig. 3. Gate characteristics of the gate camera.

Relative phase and energy gain measurement

The relative phase and the power of the compensation sections were measured by scan the phase of the compensation sections. The profile center of one of the bunches measured by the OTR monitor were plotted in Fig. 4. The deviation from fitted value is come from the non-linearity of the phase shifter.

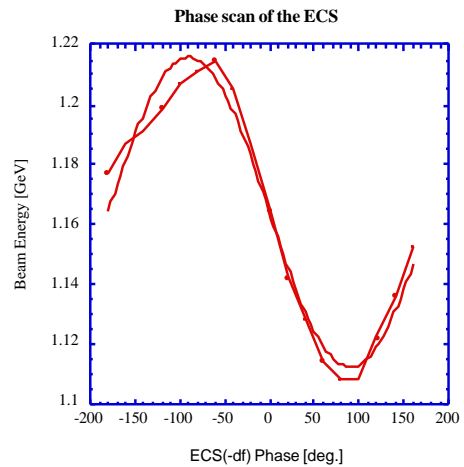

Fig. 4. Phase scan of the compensation section.

Multi/single bunch energy spread measurement

The experiment was carried out following conditions, Energy = 1.16 GeV, bunch number = 20, total charge/pulse = 3.2 × 10¹⁰, 5.3 × 10¹⁰ electrons. It was measured at the case of a) ECS off, b) ECS+ f on, c) ECS± f on. The bunch shape is

shown in Fig. 5. The multi-bunch energy spread was calculated from the current of the bending magnet and the deviation from the center position of the profile which was measured by the OTR monitor. The single-bunch energy spread was measured from the FWHM of the x-direction distribution of the profile. The multi-bunch energy spread and the single-bunch energy spread was plotted in Fig. 6a), 6b) and Fig. 7a), 7b), respectively.

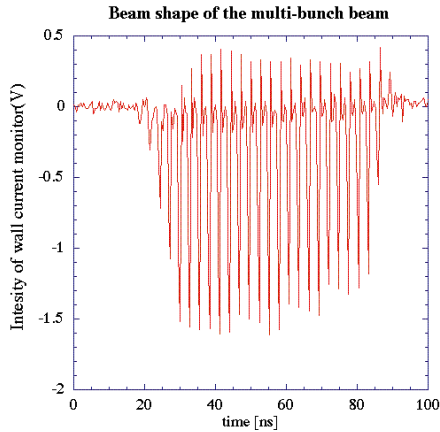

Fig. 5. Beam shape of the multi-bunch by the wall current monitor at the end of the ATF linac.

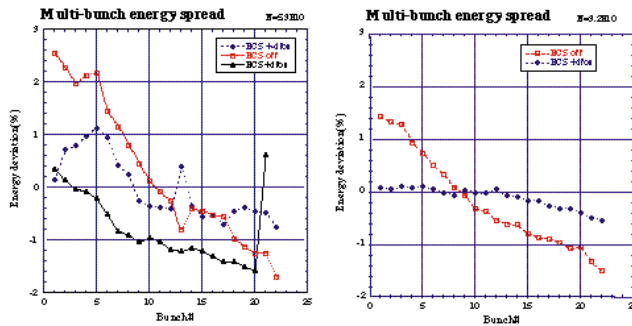

Fig. 6. Multi-bunch energy spread: a) total charge/pulse = 5.3×10^{10} , b) total charge/pulse = 3.2×10^{10} .

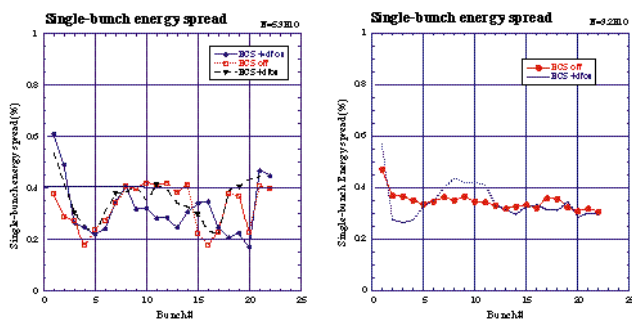

Fig. 7. Single-bunch energy spread: a) total charge/pulse = 5.3×10^{10} , b) total charge/pulse = 3.2×10^{10} .

Summary

We could measure the multi-bunch energy spread and the single-bunch energy spread of the ATF linac using the OTR monitor. The ECS effect was confirmed that the multi-bunch energy spread was reduced from 3% to 0.5% at the case of total charge/pulse = 3.2×10^{10} , 5% to 1% at the case of total charge/pulse = 5.3×10^{10} , respectively. These results were larger than the calculated value from the transient beam loading. It's assumed that the RF timing of each section were not optimized for minimize the multi-bunch energy spread. The single-bunch energy spread was less than 0.5% except for first bunch at the case of total charge/pulse = 5.3×10^{10} . Some deterioration for single bunch energy spread by the ECS effect wasn't observed in these intensities.

Acknowledgment

We would like to express our thanks to Professors Y. Kimura and K. Takata for their encouragement. We also thank other members of ATF group and Mr. S. Morita of E-cube Corporation for their support.

References

- [1] JLC Group, "JLC-I", KEK Report 92-16, 1992.
- [2] T. Naito et al., "Bunch by bunch beam monitor for ATF Injector Linac", Proc. of LINAC94, Tsukuba.
- [3] M.J. Mordan, "Practical application of coherent transition radiation", NIM B33 (1988) p. 18.
- [4] D.W. Rule et al., "Beam profiling with Optical Transition Radiation", Proc. of Particle Acc. conf. Washington, 1993.
- [5] X. Artru et al., "Experimental Investigation on geometrical resolution of electron beam profiles given by OTR in the GeV energy range", Proc. of Euro. Particle Acc. conf., 1996.
- [6] S. Kashiwagi et al., "Preliminary test of $\pm f$ energy compensation", in this conference.