

## ENGINEERING, MAINTENANCE, AND NEW INITIATIVES TO IMPROVE LAMPF BEAM AVAILABILITY AND SYSTEM RELIABILITY

Harlan W. Harris, Russell A. DeHaven, Valgene E. Hart,  
William M. Parsons, and James C. Sturrock  
Los Alamos National Laboratory  
P. O. Box 1663, MP-8, MS-H826  
Los Alamos, New Mexico, USA 87545

### Abstract

Two different requirements are driving engineering studies and hardware development to improve LAMPF. The first is concerned with component and system improvements to increase beam availability during the LAMPF production cycle. Hardware changes in RF, power supplies, and magnets are being implemented to increase mean time between failure and reduce time to replace or repair failed units. A joint LAMPF-Industry project is on-going to improve reliability of RF components. A component test stand is being refurbished to include significant development capability. The second approach includes several changes that will increase the duty factor of the existing accelerator. Major changes are being evaluated for replacing the front end of the accelerator. Other changes improving the high brightness capability could result in a new performance plateau for LAMPF.

### Introduction

The Los Alamos Clinton P. Anderson Meson Physics Facility (LAMPF) is a half-mile-long linear particle accelerator. Beams of  $H^+$ ,  $H^-$ , and polarized  $H^-$  are available. Both positive and negative ions are accelerated simultaneously. LAMPF produces an 800 MeV ion beam at an average current of near one milliamperere.

Improvements to increase the beam availability include hardware changes to the 201 MHz RF, replacement of 805 MHz RF switch tubes that are no longer produced, changes to power supply controllers, and redesign of critical magnets in the Proton Storage Ring to be more radiation resistant. Other changes that cannot be covered in a three page paper include: increased vacuum system pumping capability in key systems, replacement of heat exchangers to permit easy cleaning and avoiding hazardous chemicals in cleaning, upgrade water flow switches and water-cooled cables, a system approach to replacement of hardware, and a systems approach to include maintenance in any and all equipment changes.

Improvements, which will allow increase in the duty factor, include additions to the facility water cooling towers, system evaluation of improved cooling distribution to accelerator and experimenter hardware, use of newly reconfigured RF test stands for tube testing and development programs, system studies and tests to optimize the efficiency of the 805-MHz RF klystrons, and duplication of vacuum pumps and other key equipment in which performance degradation or failure would cause beam down-time.

### Improvements to Increase Reliability

#### High Power Radio Frequency Systems

The LAMPF 201.25 MHz Alvarez drift tube LINAC is powered by four modules. Each module consists of a cascade of four grided tubes. The maximum duty factor for the RF systems must be approximately 14% for an accelerator beam duty factor of 12%. The peak power for Modules 2, 3, and 4 is 3 MW during accelerator tank fill time and drops to 2.6 MW while the beam is present. The LAMPF 805 MHz side-coupled LINAC consist of forty-four structures each powered by a klystron. The peak pulsed power level is about 1.2 MW. Compared to the reliability of the forty-four 805 MHz modules, the four module 201.25 MHz system has been responsible for more than twice the accelerator down-time in recent years.

#### 201 MHz RF

The 201.25 MHz module used over the last twenty years is a four vacuum tube chain consisting of two 7651 tetrodes, a 4616 tetrode and a 7835 power triode. Figure 1 shows the proposed changes in these modules. A solid state 5 kW amplifier will replace the first two vacuum tubes and seven associated power supplies. This simplifies the RF system and reduces annual maintenance.

The 4616 modulator circuit will be replaced with a switching type anode power supply. Tentative requirements for the power supply are 17 kV, 3 A average current, and 15 A peak. Protective circuitry for fast shut-off will be necessary.

The 7835 power amplifier is plate modulated by two 4CW250,000 tubes in parallel. Circuitry will be redesigned to accommodate unmatched tubes. The tube type video driver will be replaced with a hybrid circuit consisting of an incoming fiber optic link, high power MOSFET followed by a 3CX2500F3 triode.

A major improvement will be the addition of more abundant instrumentation and an advanced data logging system. This equipment will be the key to providing failure trend analysis, maintenance lists, and materials for training.

A joint development program between Burle Industries and LANL has modified the 7835 system power triode to include two penning gages. This modification makes it possible for the first time to observe filament turn-on gas bursts and to monitor the vacuum during the lifetime of these tubes. With this additional diagnostic, the tube conditioning procedure has

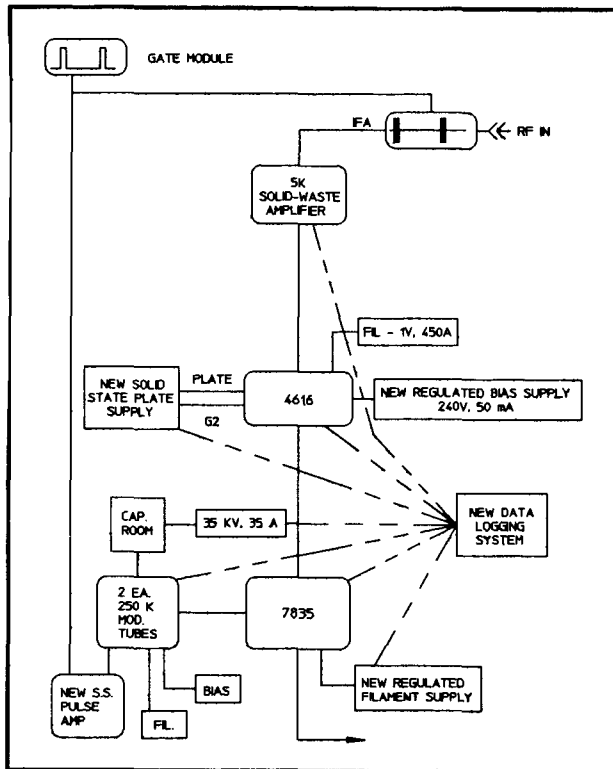

Fig. 1 201.25 MHz RF Configuration for Module 2

been changed to avoid operating under poor vacuum conditions. The penning gages act as vacuum pumps, shortening the down-time after turning on the filaments. Other joint activities include analysis and dissection of failed units, alternate ceramic material, and ceramic seal development.

### 805 MHz RF

The major changes in the klystron system are in the switch tubes. The modules originally used Machlett LPT-44 tubes that are no longer manufactured. In one of seven sectors of LAMPF the Machlett tubes have been replaced with Litton L-3408 switch tubes. Conversion to these tubes require modification of the klystron modulators. A search for sources to rebuild LPT-44 tubes and an evaluation of alternate tubes, which would not require extensive module modification will be completed before converting the remaining sectors.

The 805 MHz system uses two different klystrons. The Varian VA-862 and the Litton L-5120. As these tubes fail they are rebuilt and tested at the LANL Equipment Test Laboratory. Future direction may require replacement of windows on some units. This may provide another opportunity for LANL-Industry development.

### Power Supply Controllers

The major improvement to the d. c. magnet power supply systems at LAMPF is the recent design and introduction of a new power supply controller that contains embedded

microcomputers. These controllers are being used in 25 new supplies and in the magnet mapping area. The controller is designed as a self-contained unit that can be used in any power supply.

In the LAMPF standard power supply design, a stepper motor-driven potentiometer was used to set output current. These potentiometers have limited resolution, (1 part in 2000), are subject to mechanical problems and must be used as open circuit input devices. This results in an appreciable amount of down-time for service and makes tuning of the beam a time consuming task. The new controllers have no moving mechanical parts, can be set in milliseconds, operate as closed loop controllers, and set themselves accurately to the desired output currents. In addition the controllers have diagnostic routines to assist the technicians in their repair back in the power supply shop.

In the current LAMPF standard power supply control system there are 176 interconnecting wires between the remote control, the reversing switch and the power supply. The new system does the same job with just 14 wires. In addition, the power supply can be directly wired to the control computer by two, twisted pairs of wires via an RS 422 port. The new controllers use all digital logic except in the heart of the regulation loops. The new one-box design lends itself to automated testing and computer-aided trouble shooting back at the shop rather than manual diagnostics on 10 plus units in the field. The controller software can be easily changed to meet new conditions as they arise.

The result of all of this is that the new controller is more reliable, easier to maintain, and lends itself to be easily adapted to changing requirements.

### Magnets

Magnets within the LAMPF and PSR are continually being evaluated to estimate when they may need to be replaced. Spares are provided for many critical magnets so a sudden failure would not result in a lengthy machine down-time. Magnets which have provided only a limited life in a harsh environment are being redesigned. The PSR septum magnet, shown in Figure 2, is used as an example.

A septum magnet is used to further separate two adjacent beams after they have been split. There is typically very little space between the beam paths for beam pipes, coils, insulation, and iron. Consequently the current density in the coil septum is very high.

Inadequate cooling or errant beams can cause overheating and damage to the insulation resulting in ground currents. The ground currents then contribute to the heating and possibly even damage the vacuum envelope.

Epoxy base insulation is subject to breakdown in high radiation shields. High temperature inorganic (rad hard) insulators also have limitations. The standard mineral insulated conductors have a rather low packing factor and are not suitable for the septum coil. Vitriol coatings are fragile and arc sprayed alumina is susceptible to water damage. All of these insulators have been used in various magnet applications



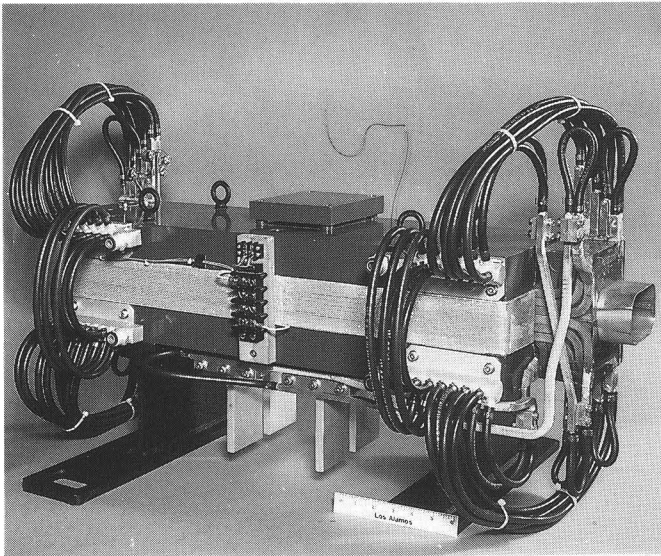

Fig. 2 Spare PSR Septum Magnet

at LAMPF.

All techniques listed above and any new possibilities should be reviewed for specific septum applications in the future to enhance magnet reliability.

### Improvements to Increase Duty Factor

#### Cooling Towers

Additional cooling tower cells are needed to meet the expanding experimental needs. With increased duty factor, additional cooling will be needed for the accelerator and RF systems as well. By providing a versatile cooling water distribution system and interconnects, the system can be optimized to meet ever changing needs.

#### RF Test Stands

201.25 MHz and 805 MHz test stands in the Engineering Test Laboratory Building have previously been used to condition tubes and klystrons. These test stands have been upgraded and reconfigured to be versatile as development test stands. Components and circuits can be certified at increased performance levels and proven reliability before being incorporated into the LAMPF accelerator.

#### Klystron Efficiency

Beginning with the FY91 production cycle, fine adjustments were made on individual klystron modulators to optimize efficiency. The limitation on this approach is that as modules need to be removed during the operating period, the performance of the replacement modules will not be optimized and efficiency will temporarily be reduced. An alternate, which would also increase efficiency, would be to upgrade to high

efficiency klystrons.

### Future Direction and Opportunities

Many different operating modes are being considered. The changes needed in LAMPF to meet various options are vastly different in approach, complexity, and cost.

The present Medium Energy Physics program is directed towards meeting the needs of users and providing for the maximum number of simultaneous experiments. This program is supported best by improving the reliability of the accelerator at present operating conditions and the addition of new beam lines providing new capabilities.

An upgraded proton storage ring program may well need operating of LAMPF for eight or more months each year at high availability. High power multi-MW beam applications would require a new front end. One possibility is a volume ion source, radio frequency quadrupole, longitudinal chopper, and 402.5 MHz drift tube linac.

### Acknowledgements

Special thanks goes to Roger W. Johnson and Jerry L. Davis for their work in the low level RF and their assistance with the specifications and vendor selection for the LAMPF 5.5 kW RF Amplifier. Danny Doss deserves special appreciation for his recent work in the crowbar chassis and for discussions with gridded tube and klystron manufactures and in the preparation of a position paper on improvement and upgrade of the 201 MHz RF source at LAMPF. Robert Cady deserves special acknowledgement for years of rebuilding LAMPF klystrons and preparing databases on tube history. Thanks goes to Richard Cliff for his failure analysis and coordination of development activities with Burle Industries, Materials Science and Technology Division at LANL, and the Medium Energy Physics Division at LANL. Vincent LoDestro with BNL has been extremely helpful in his RF working session visits to LAMPF and for discussion of upgrades of common interest to BNL and LANL. Ed Bush is given special praise for his years of magnet design and fabrication at LAMPF, recent evaluation of magnet upgrade needs, and in preparing the magnet portion of this paper.

### Additional Reference Material

- (1) Richard Cliff, Edgar D. Bush, Russell DeHaven, Harlan Ward Harris, W. Mark Parsons, "Development and Directions in 200 MHz Very High Power at LAMPF", RF EXPO East 1991, Orlando, FL, October 29, 1991.
- (2) W. M. Parsons, J. T. M. Lyles, and H. W. Harris, "Modulation Improvements in the 201 MHz RF Generator at LAMPF", 1992 20th International Power Modulator Symposium, Myrtle Beach, FL, June 23-25, 1992.