

TRANSITION FITTINGS BETWEEN ALUMINUM AND STAINLESS STEEL COMPONENTS OF CRYOGENIC ACCELERATORS*

Will E. Fox, Nathan K. Bultman
 University of California, Los Alamos National Laboratory
 P.O. Box 1663, MS H821, Los Alamos, NM 87545

Abstract

The use of copper-plated aluminum for cryogenic rf structures requires that a transition fitting be placed between the rf cavity and the stainless steel cryogen manifolding. The fitting must accommodate the significant loads that result because the aluminum and stainless steel contract differentially as the cavity undergoes thermal cycling from 300 K to 20 K. The fitting must also accommodate loads resulting from installation forces. Because the commercial fittings we evaluated for this application were unsatisfactory, we initiated a development program to produce a fitting that had good structural properties, was easily repairable in the event of a leak, and could be customized to a specific application. We evaluated both an explosive-bonded fitting and a low-temperature-soldered fitting. We conducted structural tests at 300 K, 20 K, and 4 K to determine failure mechanisms, and allowable stresses.

Introduction

The development of a copper-plated aluminum radio-frequency quadrupole (RFQ) that operates at cryogenic temperatures represents a major accomplishment for the Neutral Particle Program. Many difficult design and fabrication problems had to be solved in the development of this RFQ. The one that is the subject of this paper is the transition fitting between the stainless-steel coolant manifolding for the RFQ and the aluminum RFQ vanes (see Fig. 1).

The RFQ operates at 35 K and is cooled by gaseous helium at a pressure of 300 psi. The coolant manifolding is constructed of 304L stainless steel and the RFQ of copper-plated 2219 T851 aluminum. It was necessary, therefore, to incorporate a transition fitting between the aluminum RFQ vanes and the stainless steel manifolding. The fitting would have to withstand the following loading conditions:

- a. A 35-ft-lb torsional load required for assembly.
- b. A 350-psi proof test of the helium manifolding.
- c. The thermal stress produced by multiple temperature cycles between 300 K and 35 K.
- d. Additional thermal stress resulting from the electron-beam (e-beam) welding of the fitting into the RFQ vane.

Commercial fittings developed for applications similar to this are readily available in 1000-, 3000-, and 5000-series aluminum alloys. A commercial fitting known as a Trision fitting, developed by Applied Fusion Inc., was selected for our application. It incorporates a silver interface between the aluminum and the stainless steel that is produced by a proprietary e-beam brazing process. This process has produced successful Trision fittings using both 1100- and 3003-series aluminum with 304 austenitic stainless steels, and we assumed it would work equally well on the 2219 T851 aluminum selected for the RFQ. This type of aluminum was selected because of its excellent properties at cryogenic temperatures and its high strength in the welded condition. It produces excellent e-beam welds, which is absolutely necessary for installation of the transition fitting with minimum distortion of the RFQ vanes.

Testing of Commercial (Trision) Fittings

Prototype Trision fittings were developed and successfully underwent extensive mechanical and thermal testing. But when the fittings were welded into the vanes, several leaked. These were removed and replaced, but some of the new fittings still leaked. A careful check showed that the leaks were in the stainless-to-aluminum bond in the fittings, not in the e-beam weld to the vanes. Some leaking fittings exhibited considerable evidence of corrosion of the aluminum (caused by exposure to machine-tool-cutting fluid and cleaning fluids, such as deionized water, alcohol, and trichloroethylene). Examination of the failed fittings showed that in some, the joint had separated at the interface between the aluminum and the silver. We concluded that the production Trision fittings had been subject to poor process control during cleaning and preparation prior to e-beam brazing. (This was quite evident from micrographs of fittings, showing flaws and porosity at the interface between the silver and the aluminum.) The aluminum/silver interface alloy also exhibited brittle material behavior, leading to catastrophic failures.

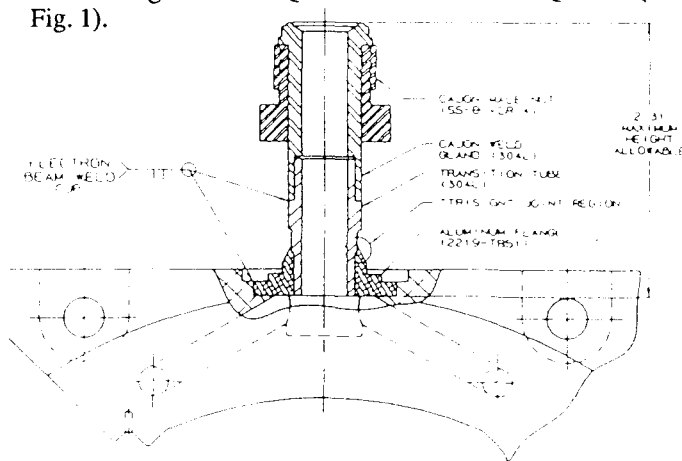

Fig. 1. RFQ vane section illustrating the transition fitting between the 2219 aluminum vane and the 304 stainless steel manifolding.

*Work supported and funded by the US Department of Defense, Army Strategic Defense Command, under the auspices of the US Department of Energy.

Transition Fitting Development Program

In response to the problems encountered with the Trision fitting, we developed three alternative approaches to the aluminum-to-stainless-steel joint. These approaches were an explosive-bonded fitting, a soldered fitting, and a mechanical joint. In this paper, we discuss the results of our development program on the first two.

Explosive-Bonded Fitting

A section drawing of the explosive-bonded fitting is shown in Fig. 2. The explosively bonded portion of the fitting was produced by machining samples cored from a larger plate composed of 2219 aluminum bonded to 304 stainless steel with a 0.5-mm interstitial layer of silver. Both aluminum and iron are soluble in silver, which provides the mechanism for bonding. An explosively bonded composite plate of 2219 aluminum/silver/304 stainless steel was obtained from Northwest Technical Industries, Inc., for evaluation. Initial testing was conducted with tensile test specimens having a 3.12-mm diameter test section. Tests were conducted at both 300 K and 77 K. The results are shown in Table 1.

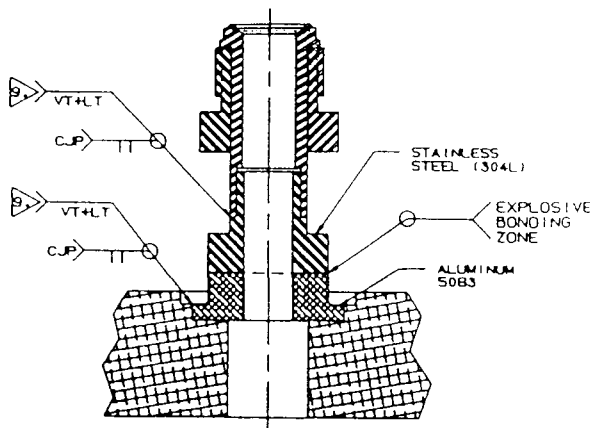

Fig. 2. Explosive-Bonded Fitting

TABLE 1

Tensile test results of 3.125 mm (.125 in.) diameter explosive-bonded test specimen.

Specimen	Test Temperature (K)	Load at Yield (lb)	Stress at Yield (psi)	Load at Failure (lb)	Stress at Failure (psi)	Failure Description
XB-0.1250	300	-	22857	287	22857	Brittle
XB-0.125	77	-	26646	327	26646	Brittle

NOTE: Load rate was 1.25mm/min (0.050 in./min).

The explosive-bonded joint displayed excellent strength but failed because of brittleness. Failure occurred in the intermetallic zone between the silver and the aluminum.

Tensile tests were then conducted on full-scale prototypes. The results are shown in Table 2. Ultimate stresses achieved with the prototype fittings were

considerably less than those achieved with the smaller specimens, indicating the likelihood of unbonded regions within the joint of the prototypes. Brittle failure mechanisms were again evident at the silver/aluminum interface, which would support the likelihood of unbonded regions; these contribute to crack initiation and propagation, resulting in lower apparent ultimate strengths. Examination of the load-vs.-displacement charts revealed no plastic deformation prior to failure.

The following conclusions may be drawn from the effort to develop explosive-bonded transition fittings. Explosive-bonded joints have the potential of achieving very high ultimate strengths. The small diameter samples demonstrated ultimate strengths of 27,000 psi at 77 K. However, the explosive-bonding process gives rise to regions of poor bonding. The intermetallic between the aluminum and the silver exhibits a brittle failure mechanism, which is of concern for this application. This particular type of transition fitting for the RFQ was deemed unacceptable as developed to this point.

TABLE 2

Tensile test results of prototype transition fittings.

Specimen	Test Temperature (K)	Load at Yield (lb)	Stress at Yield (psi)	Load at Failure (lb)	Stress at Failure (psi)	Failure Description
XB	300	-	3433	2825	3433	Brittle
XB	77	-	2613	2150	2613	Brittle
¹ A-14	77	-	6586	5420	6586	Brittle
B-22	77	5500	6684	5700	6927	Ductile
¹ B-22	77	5450	6623	5520	6788	Ductile
¹ B-24	77	5000	6076	5530	6720	Ductile
B-29	77	2900	3524	3050	3706	Ductile
¹ B-29	77	4150	5043	4340	5274	Ductile
A-450	300	3150	3828	3300	4010	Ductile
A-450	77	-	5620	4625	5620	Brittle
A-450	4	-	4678	3850	4678	Brittle

XB - Explosive-Bonded

[1] - Specimens were cyclically loaded 5 times to 1500 lbs at 77K prior to testing.

NOTE: Load rate was 1.25mm/min (0.050 in./min).

Soldered Transition Fitting

Our decision to consider a soldered transition fitting was based on the results of a recent successful development program on copper-plating aluminum, and on earlier work on this type of fitting that had demonstrated the feasibility of the concept.

Description

A section drawing of the soldered transition fitting is shown in Fig. 3. The base of the fitting is 2219-T851 and incorporates a socket for the 304L stainless steel Cajon VCR weld gland. The socket in the aluminum base is copper plated using a copper zincate process. The diameter of the stainless steel weld gland is 0.125mm smaller than the diameter of the copper-plated aluminum base, to provide a 0.0625mm gap between the two parts for a low-temperature solder. The two parts have an engagement length of 9.25mm. The aluminum portion was selected as the female half of the fitting, so that upon cool-down thermal stresses would be compressive (aluminum contracts more than stainless steel).

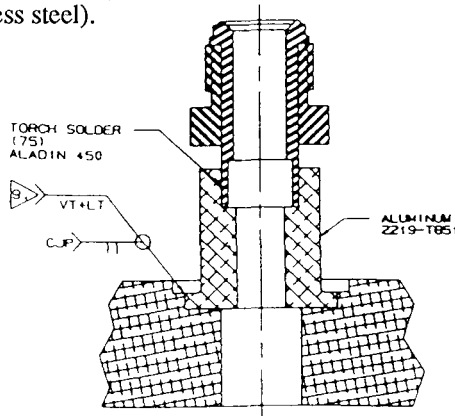

Fig. 3. Cross sections showing the geometry of explosive-bonded fittings compared with that of soldered fittings.

Selection of an appropriate solder for the joint was based on three criteria:

1. It must have minimum shear strength of 3600 psi (25.5 MP_a) at 30°C, for assembly.
2. It should exhibit ductility at cryogenic temperatures, for unanticipated loads.
3. It must have a melting point below 300° C to minimize potential for damage to the copper plate/aluminum interface but greater than 200° C to allow e-beam welding.

The following solders were considered for the joint: A-14 (50 Tin/50 Indium)-melting point 115°C, B-22 (75 Lead/25 Indium)-melting point 230°C, B-24 (95 Tin/5 Lead)-melting point 232°C, B-29 (95 Lead/5 Indium)-melting point 314°C, and A-450 (96.5 Tin,3.5 Silver)-melting point 230°C.

Testing

Tensile pull tests were conducted on full scale prototype specimens. The results of those tests are also shown in Table 2. Several specimens were cyclically loaded to 1500 lb at 77 K and then tested to failure for any tendency to work hardening in the joint as a result of thermal cycling. These results are also shown in Table 2. Table 3 shows the results of torsion tests conducted at room temperatures on various specimens.

TABLE 3
Torsion Test Results of Prototype Soldered Transition Fittings

Specimen	Test Temperature (K)	Yield Torque (ft-lbs)	Yield Stress (psi)	Failure Torque (ft-lbs)	Failure Stress (psi)	Failure Description
A-450	300	-	-	141	7340	Ductile
B-22	300	90	4685	95	4945	Ductile
B-29	300	70	3644	85	4425	Ductile

NOTE: The yield torque of the A-450 specimen was not measured.

Test Results

A literature search revealed that solders containing more than 15% tin are likely to undergo a brittle transition at temperatures below 200 K. (This behavior was confirmed by testing; and we consequently eliminated the high-tin-content solders.) Two of our high-tin solders (A-450 and A-14), while exhibiting higher strengths than the lower-tin solders, also exhibited brittle failure mechanisms at 77 K. Specimen B-24 despite exhibiting a ductile failure mechanism at 77 K and a relatively high ultimate strength, was eliminated as a candidate because of its high tin content (there was not sufficient time to conduct further tests). Specimens B-22 and B-29, both high-lead solders, exhibited acceptable ductility and strength at 77 K. B-22 exhibited the higher torsional strength and was finally selected as an acceptable solder for the transition fitting. The fitting is repairable *in situ* should a leak develop. Thirty-two of these fittings have been incorporated into the RFQ and have functioned properly during day-to-day operation.

Summary

A soldered (75-lead/25-iridium) transition fitting was selected for use on a copper-plated aluminum cryogenic RFQ with stainless steel manifolds. This fitting proved to have more than adequate strength at both cryogenic and room temperatures and displayed acceptable ductility at both.

A commercial fitting known as a Trision fitting was also evaluated and found to be unacceptable because of brittle failure characteristics and poor quality control. This fitting also appeared to be vulnerable to corrosion-induced failure.

An explosive-bonded fitting was also evaluated and found to have excellent strength characteristics in small specimens. Large specimens exhibited considerably lower strengths because of lack of uniform bonding. Explosive-bonded fitting also exhibited brittle failure mechanisms at both room temperature and 77 K, thus making them unacceptable candidates for application to the cryogenic RFQ.