

**CALIBRATION AND OPERATION SCHEMES  
FOR CEBAF RF CONTROL\***

S.N. Simrock, J.C. Hovater, I. Ashkenazi  
G.E. Lahti, K.L. Mahoney, and J.A. Fugitt

Continuous Electron Beam Accelerator Facility  
12000 Jefferson Avenue  
Newport News, Virginia 23606

**Abstract**

The RF control system for the CEBAF accelerator uses calibration tables to calibrate and linearize critical components in the RF control modules. This includes compensation for temperature drifts. Calibration data are stored in nonvolatile RAM on the CPU board in the control module. Algorithms for calibration of components like the vector modulator for the phase reference and the gradient detector are described. The calibration will be performed in a dedicated test stand which will be completely automated. The microprocessor in the control modules allows running of complex algorithms to achieve phase lock and optimize system gains for minimum residual errors for different gradients and beam loading.

**Introduction**

The CEBAF RF control system<sup>1-5</sup> has to control the gradient and phase in the 338 superconducting cavities of the CEBAF accelerator. In addition RF control for the two chopper cavities, the buncher cavity, the capture section, and up to five separators has to be provided. In the machine control center (MCC) 3 supervisory computer (SC) are available to control the injector with its 22 cavities and the north and south linac with 160 cavities each. The supervisory computers access the RF controls modules through 10 local computers (LCL) in the north and south linac and one LCL in the injector as shown in figure 1. Each LCL controls 16 RF control modules through CAMAC interface cards and the two high power amplifiers (HPA) associated with two cryomodules, each of which contains 8 cavities. The system hierarchy is displayed in figure 1. The microprocessor in the RF control module provides the local intelligence for calibration, control of loop parameters, data acquisition, interlock functions, and HPA control.

**Signals Used for RF Control**

The microprocessor in the RF control module controls 20 analog outputs, 40 analog inputs, 32 digital inputs, 32 digital outputs, and 7 interrupt inputs. Those are used to control and read parameters in the RF feedback loop, the HPA and interlocks. Figure 2 contains a partial list of the available signals.

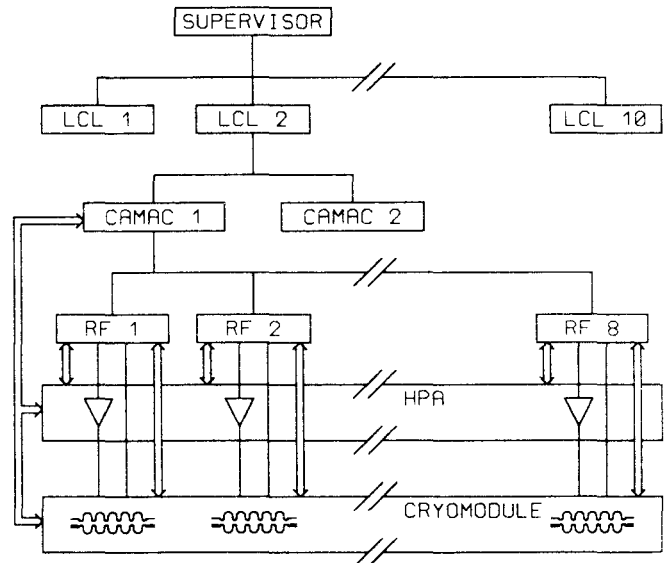

Figure 1. Computer controls for the CEBAF RF system.

**Calibration Schemes**

The calibration of the signals require characterization of the components in the RF module, HPA, coaxial cables and cavities. Components in the RF module are calibrated in a dedicated test stand, and calibration coefficients are stored in nonvolatile RAM on the CPU board. The calibration data for all other equipment and components will be downloaded from a database which can be accessed by the supervisory computer.

The two most important signals to be calibrated are the field gradient and the phase of the accelerating field in the cavities. Other signals to be calibrated are waveguide forward and reflected power, the detuning angle, and the frequency dependent system gains in the amplitude and phase feedback loop. Measured signals are compared with setpoint values. Critical signals will be monitored in 50 ms intervals, less critical signals every 500 ms. Interlock procedures, alarms, or warnings will be initiated if signals are out of range. The signals are also compared with predicted values to indicate fault or improper operating conditions. The forward power, for example, will be calculated as a function of beam current and detuning angle. A rapid (< 50 ms) decrease in the gradient or a high ratio of forward power to transmitted power indicates a quench and shuts down beam and RF drive.

\* Supported by U.S. Department of Energy under contract DE-AC05-84ER40150.

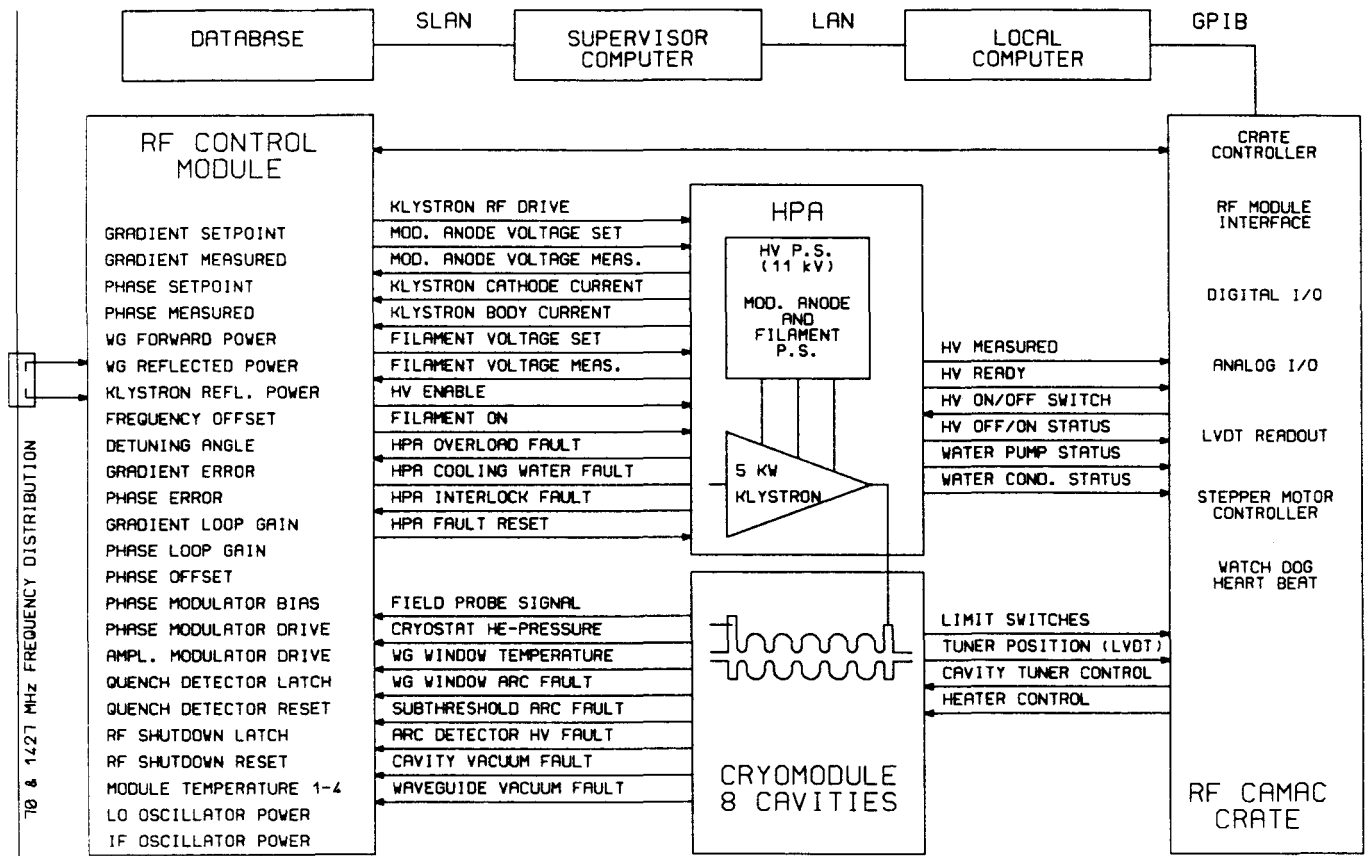

Figure 2. Signals used in CEBAF RF control system.

### Gradient Calibration

The gradient detector is a schottky diode located on the converter board. It will be driven in its linear range at about 13 dBm at 5 MV/m. The calibration of the detector output voltage versus input power to the RF control module will be performed in the RF module test stand. Cable attenuation and field calibration coefficients will be downloaded from the database to the nonvolatile RAM. The field gradient is calculated as

$$E_{acc} = \alpha \cdot \sqrt{P_t}$$

with

$$P_t = \frac{1}{\sqrt{\gamma_1(t) \cdot \gamma_2(t)}} \cdot f(a_i, V_d)$$

with the field calibration constant  $\alpha$ , cable attenuation  $\gamma_1$ , HOM filter attenuation  $\gamma_2$  and the detector voltage  $V_d$ . Absolute accuracy is about 20% determined mainly by the precision of the field calibration. A better field calibration can be achieved by a measurement of the change in beam energy when varying the gradient. The calibration will be affected by temperature changes of the cables and the HOM filter in the converter. These are measured and used for correc-

tion of the gradient setpoint.<sup>6</sup> The detector diodes are oven stabilized to  $(71 \pm 1)^\circ\text{C}$  to avoid complicated compensation algorithms for temperature changes. The temperature stability of gradient detection will be  $\approx \pm 2 \cdot 10^{-5}/^\circ\text{C}$ . Remaining drifts will be regulated by a vernier system which measures the beam energy at the end of each linac and corrects the gradient setpoint in selected cavities.

### Phase calibration

Phase detection takes place at 70 MHz by use of analog multipliers<sup>7</sup>. The phase setpoint is controlled by a vector modulator consisting of a  $90^\circ$  hybrid, two analog multipliers, and a combiner. The two control voltages are set to  $V_x = V_0 \cdot \sin(\phi)$  and  $V_y = V_0 \cdot \cos(\phi)$  respectively. Differences in gains in the multipliers, nonlinearity effects, and finite isolation between inputs and output give us an intrinsic accuracy of about  $\pm 2^\circ$ . With calibration algorithms a relative accuracy of  $\pm 0.15^\circ$  can be achieved. The control signals have to be modified to

$$V_x^i = \sum_{i,j=0}^N a_{ij}(t) \cdot V_x^i \cdot V_y^j$$

$$V_y^j = \sum_{i,j=0}^N b_{ij}(t) \cdot V_x^i \cdot V_y^j$$

$a_{00}$  and  $b_{00}$  compensate for offsets due to finite isolation between input and output,  $a_{10}$  and  $b_{01}$  for different gains of the orthogonal signals. Higher order terms correct for nonlinearities. Systematic errors in the calibration process with the network analyzer are eliminated by two measurements with different cable length and therefore different phase offsets in the measurements. For the measurement, the control inputs of the vector modulator are stepped through from -1.0 V to +1.0 V in 0.1V steps. The resulting phase errors are up to  $\pm 2^\circ$  as shown in figure 3a. With the corrected values for  $V_x$  and  $V_y$  the error is reduced by one order of magnitude as shown in figure 3b. Typical temperature sensitivity of the vector modulator is  $0.14^\circ/\text{C}$ . Temperature sensors monitor the temperature of the multipliers and will be used to correct the calibration coefficients for temperature changes. An environmental oven in the test stand will be used for for all temperature dependent calibrations.

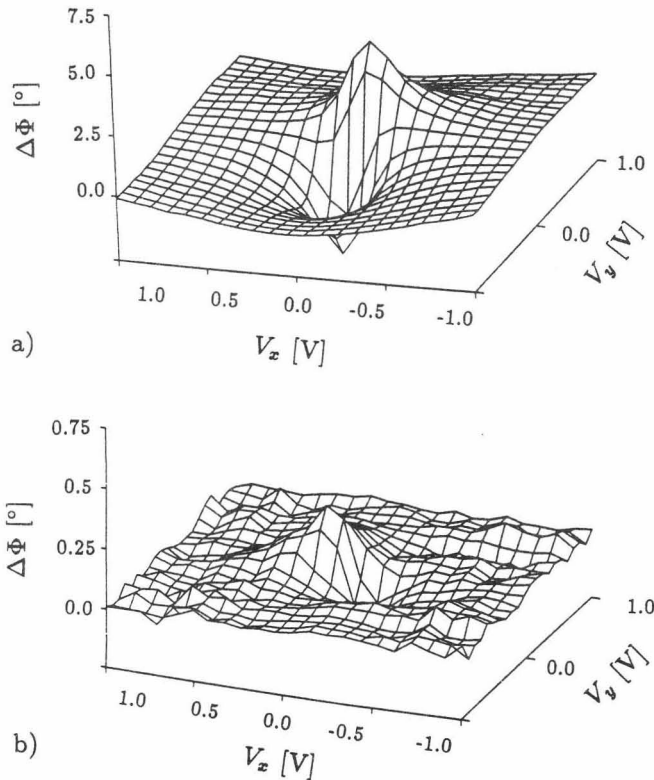

**Figure 3.** Phase error of vectormodulator. a) uncalibrated and b) calibrated. The calibration coefficients are optimized for  $\sqrt{V_x^2 + V_y^2} > 0.4V$

### Operation Schemes

The 160 cavities in the injector and the two linacs will be operated from 3 RF supervisory computers in the MCC. The SC for the linac will use two monitors, one for the actual control, the second as a status display and for alarm and warning messages.

The control logic treats the the RF control for the 8 cavities in one cryomodule as a state machine with the following states:

- Idle Mode
- Filament Mode
- HV Mode
- RF Mode

The main control screen for one linac displays push buttons for each 8 seater HPA, displaying 20 HPA's (8 klystrons per HPA) at one control screen. The operator has to go manually through the whole sequence to turn the RF on.

In "idle mode" all hardware will be running, the RF modules will perform continuous checks of all RF system associated hardware and bring any fault to the attention of the operator. In this mode down loading of external calibration parameters will be enabled. Those parameters are stored in the nonvolatile RAM on the CPU board. They describe cavity parameters, HPA characteristics, and cable losses. Downloading will be necessary if parameters change or an RF control module is replaced. In "filament mode" the filaments of the 8 klystrons in an HPA will be turned on giving a HV ready after a warmup time of 5 minutes. If the interlocks show no fault, "HV mode" is used to turn on the klystron cathode voltage for 8 klystrons. At this stage the RF can be turned on by pressing "RF mode". In case of an interlock trip the machine will go back to a safe state. The fault indicators display the HPA and the RF control channel that showed a fault.

In "RF mode" the operator has the choice between "two knob" operation or "expert" mode. In "two knob" operation the operator has only access to phase and gradient setpoint but can control the eight cavities in a cryomodule from one screen. In "expert" mode the operator can access all parameters in the RF control module. This mode allows control of only one cavity from a screen.

### Expert Mode

This mode is used for debugging purposes, allowing extensive diagnostics of one of the RF control channels. In this mode the operator has access to about 30 parameters in the RF control loop. The parameters are phase and gradient setpoints, measured values and error signals, loop gain parameters, phase offset, error window setpoints, open and closed mode switches, gradient clamp voltage, several bias voltages, the RF attenuation, RF shutdown switch, and readings for 70 MHz and 1427 MHz local oscillator (LO) power.

## Two Knob Mode

This mode will be the normal operating mode. Since the operator has control only over the gradient and phase setpoint, all other parameters have to be preset or automatically derived from other machine parameters. The loop gains will have standard preset values but can be permanently modified in the "expert" mode. An example for automated procedures is the offset phase, which adjusts the optimum operating point of the phase controller. The averaged modulator drive signal is measured continuously and should be zero if the cavity is on resonance. Deviations from the expected value are used to correct the offset phase. Another example is the gradient clamp voltage which limits the maximum possible RF drive to avoid excessive forward power to the cavity. This setpoint is calculated from power requirements which depend on beam current, detuning angle, and microphonic noise levels.

## Interlocks

Interlocks are used to prevent damage to the RF control system including the superconducting cavities. Fast interlock circuits such as waveguide arc detector, beam pipe vacuum, and cavity quench detector are implemented in hardware, while slow varying or less critical parameters such as waveguide window temperature, ratio of transmitted to incident power or detuning angle are software controlled interlocks. The hardware generated trip signals use the fast (beam) shut down system and the RF kill input to interrupt beam and/or RF. Software interlocks use the available signals in the RF control module. For example, the detuning angle is monitored in 50 ms intervals. If it exceeds 20°, the motor tuner will be activated to bring the cavity to its home position.

## Conclusion

In this paper the basic ideas of calibration and operation procedures for the CEBAF RF control system are discussed. The RF control modules are calibrated in a dedicated test stand and calibration parameters are stored in nonvolatile RAM in the RF control module. Other calibration data will be downloaded to the RF control module during operation and updated if necessary. The calibration scheme uses algorithms which include temperature dependency of calibration coefficients. Each module contains four temperature sensors to monitor the critical elements and uses the temperature information of the feedback cable to correct phase and gradient setpoint to compensate for temperature changes. The algorithms will be extensively tested in the front end test (FET) which involves all 18 superconducting cavities of the injector.

From an operational standpoint, the RF controls will be treated as state machine with four different modes for each HPA. The highest level is the "RF mode" in which the "two knob" operation will be normally used for phase and amplitude control. In "expert" mode all 30 parameters of the RF control modules are accessible for debugging and diagnostic purposes. The "expert" mode has been a powerful tool during the 5 MeV injector test but is too cumbersome if 340 cavities have to be controlled simultaneously.

## Acknowledgement

The authors wish to express their thanks to R. Nelson, B. Vignato, B. Morgan and C. West who provided enormous help in documentation and software development.

## References

1. S.N. Simrock, J.A. Fugitt, J.C. Hovater, G.A. Krafft and C.K. Sinclair, "Operation of the RF Controls in the CEBAF Injector", *2<sup>nd</sup> European Particle Accelerator Conference*, (Nice, France, June 12-16, in print.
2. S. Simrock, C. Hovater, S. Jones and J. Fugitt, "RF Control System Development at CEBAF", *Proceedings of the 1989 Particle Accelerator Conference*, (Chicago, March 20-23, p. 1885.
3. R. Bork, C. Grubb, G. Lathi, E. Navarro and J. Sage, "CEBAF Control System", *1988 Linear Accelerator Conference Proceedings*, Newport News, Virginia, October 3-7, 1988, p. 415.
4. I. Ashkenazi and G. Lahti, "Microprocessor Control for the CEBAF RF Control Module", *Proceedings of the 1989 Particle Accelerator Conference*, (Chicago, March 20-23, 1989, p. 1861.
5. R. Bork, "The CEBAF Control System Architecture", *1987 IEEE Particle Accelerator Conference*, (Washington, D.C., March 16-19, 1987, p. 523.
6. C. Hovater, R. Abbott and S. Simrock, "Elimination of Temperature Drifts in the CEBAF RF Control System", *Proceedings of this conference*
7. C. Hovater and J. Fugitt, "Analog Techniques in CEBAF's RF Control System", *1988 Linear Accelerator Conference Proceedings*, Newport News, Virginia, October 3-7, 1988, p. 412.