

IPAC19



High Performance ECR Sources for Next-Generation Nuclear Science Facilities

Daniela Leitner

Lawrence Berkeley National Laboratory



- ECR Ion Sources Overview
- Next Generation Facility Requirements
- Design Parameters and Challenges
- Uranium Beam Production
- 3rd Generation ECR Ion Sources
- Towards 4th and 5th Generation ECR Ion Sources



View into the plasma chamber of the VENUS ECR Ion Source

Demands For Higher Charge State Ions Continue To Drive ECR Ion Source Development



- The requirements of next generation heavy ion beam facilities are barely met by current state-of-the-art ECR ion sources.
- Particular challenge: High intensity uranium beams and the versatility of beams required



VENUS - II
540 eμA (U^{32+} , U^{33+})

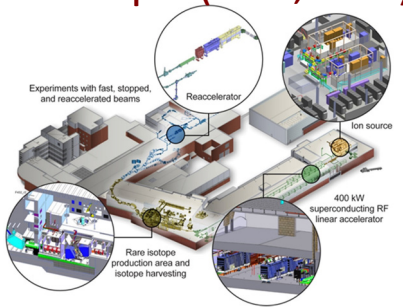

Facility for Rare Isotope Beams, East Lansing, US

1mA Ar^{12+rt}

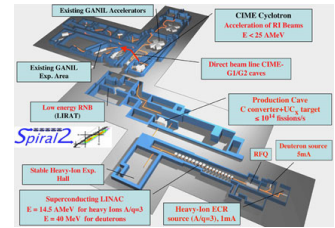

SPIRAL 2, GANIL, France

SECRAL and FECR
1.0emA (U^{35+} - U^{46+})

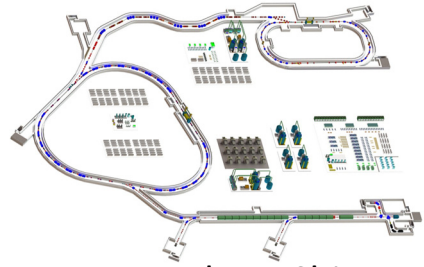

IMP, Lanzhou, China

SC-ECRIS
525 eμA U^{35+}



RIKEN Rare Isotope Beam Factory, Japan

Starting in 1972 R. Geller in Grenoble converted fusion plasma devices into the first ECR ion source.

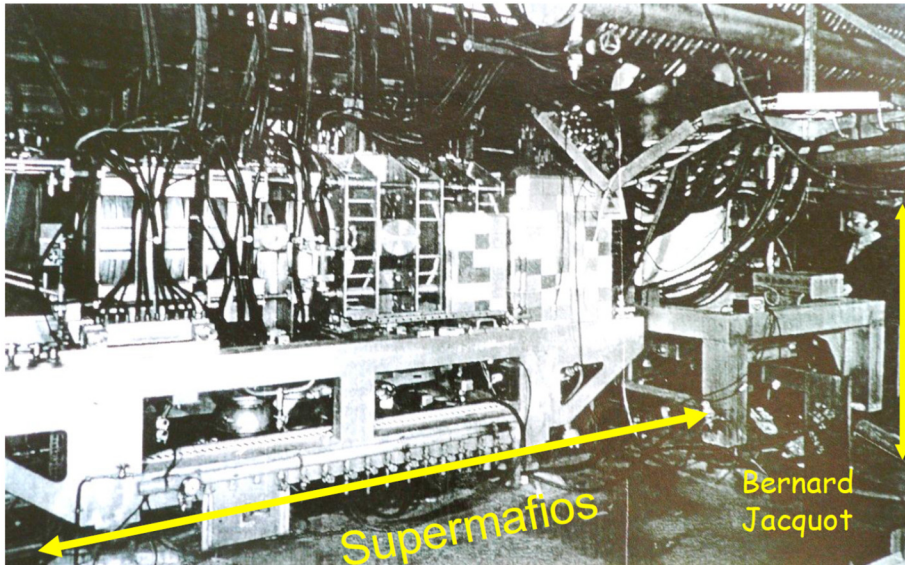

- A 3 MW modified fusion machine (CIRCE) to produce ion beams
- The legend says that, at first power switching, an electrical black out occurred on half of Grenoble city!

Supermafios (Geller, 1974)
15 μA of O^{6+}

Supermafios (Geller, 1974)
15 μA of O^{6+}

VENUS (2004)
4500 μA of O^{6+}

SECRAL-II (2016)
6100 μA of O^{6+}

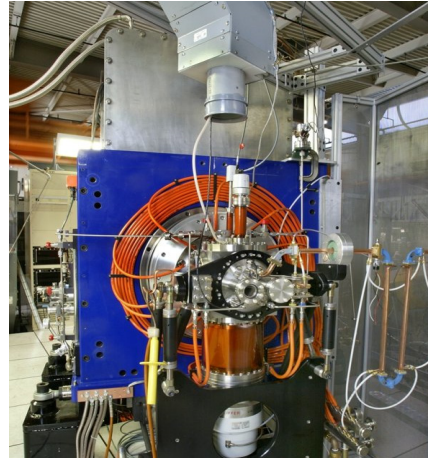
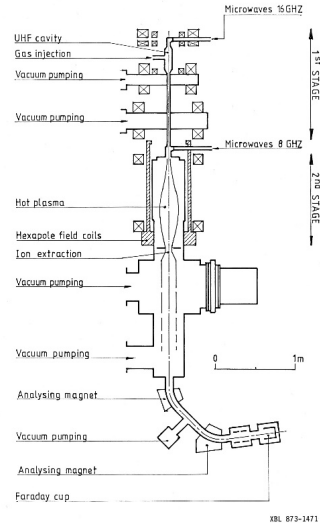

Fully superconducting NbTi ECR ion sources operating at 28 GHz Microwave plasma heating frequency are now the state-of-the-art injector sources for heavy ion facility.

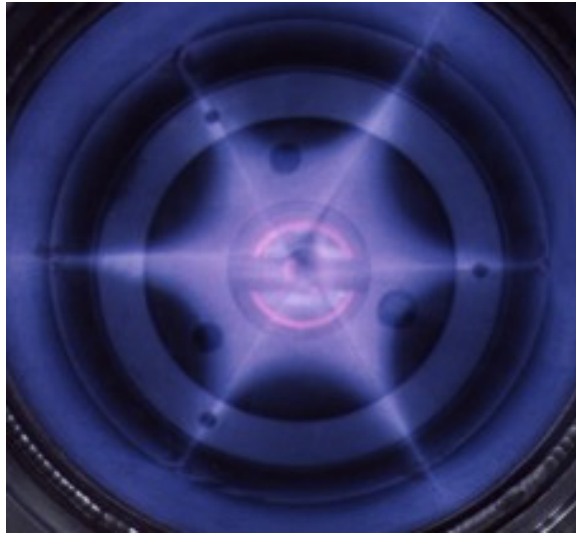

ECR Plasma

Ingredients of an ECR-Ion Source

- The plasma must be confined (magnetic fields) and heated (RF) if it should be sustained for some time
- Microwave (GHz) used for plasma heating (electrons)
 - Hot Electrons
 - Cold Ions (good emittance)
- Plasma Ions: Gas injection, vapor from external devices (e.g. ovens), sputtering
- Charge balance is determined by the neutral gas pressure in the source, electron temperature and confinement time

Plasma electrons are resonantly heated with microwaves

$$\omega_e = \frac{e \cdot B}{m} = \omega_{rf}$$

Magnetic flux line

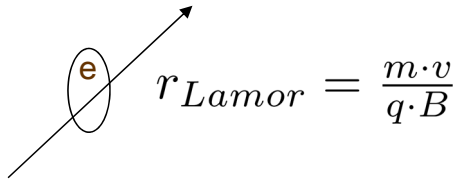

$$B = 1T$$

$$f = 28GHz$$

$$r_{Lamor} = 0.011mm$$

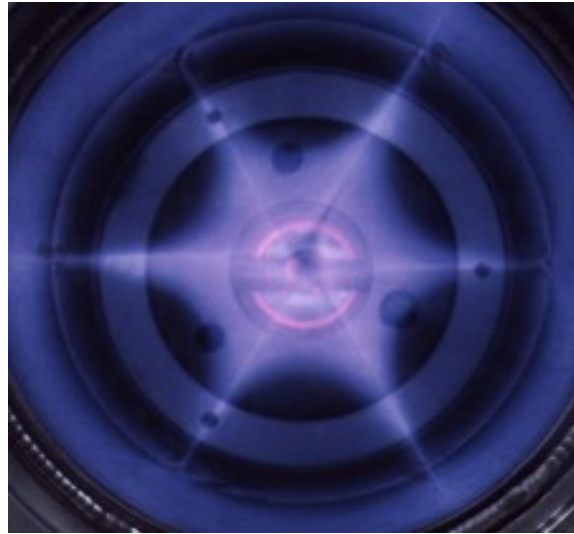

ECR Plasma

Ingredients of an ECR-Ion Source

- The plasma must be confined (magnetic fields) and heated (RF) if it should be sustained for some time
- Microwave (GHz) used for plasma heating (electrons)
 - Hot Electrons
 - Cold Ions (good emittance)
- Plasma Ions: Gas injection, vapor from external devices (e.g. ovens), sputtering
- Charge balance is determined by the neutral gas pressure in the source, electron temperature and confinement time

Minimum-B field confinement structure

$$n_e \cdot \tau_i$$

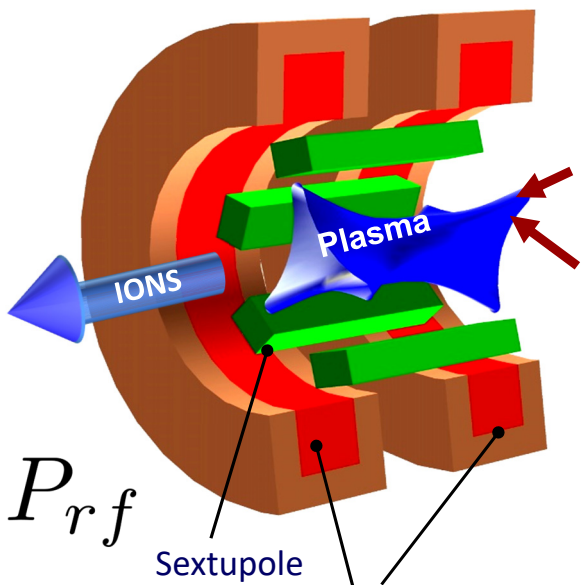

e⁻ heating
μ-wave
Gas Feed

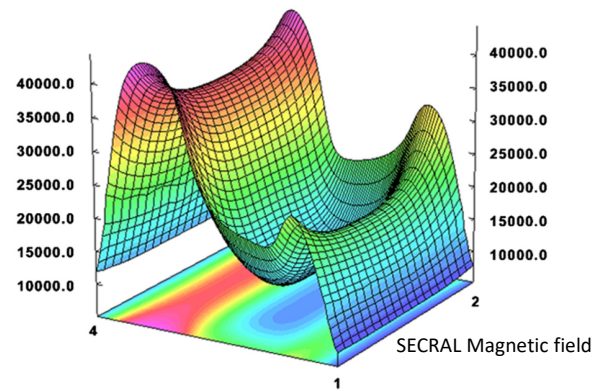

$$n_e \propto \omega_{rf}^2, P_{rf}$$

$$\tau_i \propto B_{avg}$$

Sextupole
Solenoids

Key parameters	
Ion confinement times τ_i	$\approx ms$
Plasma densities n_e	$10^9 - 10^{12}/cm^3$
Electron temperature T_e	$eV \text{ to } MeV$
Charge exchange/ neutral gas density σ_{ex}	$q^{1.17} \cdot I_p^{-2.76} \cdot cm^2$

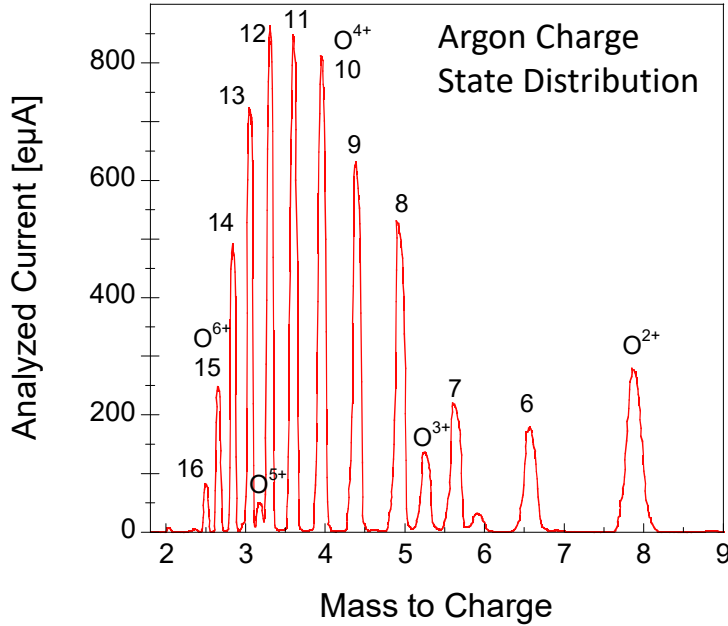

Demonstrated source performances and improvements show that next generation accelerator performance requirements are in reach, but challenges remain

Beams (eµA)	VENUS * 28+18 GHz (2018, 10 kW)	SECRAL I+II** 24+18 GHz (2018, 10 kW)	Required Intensities (eµA)
O ⁶⁺	4750	6700	> 400
O ⁷⁺	1900	1750	> 400
Ar ¹²⁺	1060	1420	> 1000
Ar ¹⁷⁺	115	133	
Xe ²⁷⁺	705	920	> 500
Xe ³⁸⁺	26	N/A	
Bi ³⁰⁺	310	710	>650
Bi ⁶¹⁺	0.1	N/A	
^o U ³²⁺	450	200	>500
^o U ³⁵⁺	300	N/A	>500
U ⁴⁷⁺	5	N/A	>1000

*Dan Xie, ECRIS2018-MO02, Catania, Italy, 2018

^oJanilee Benitez, ECRIS2012, Sydney, Australia, 2016

**Liangting Sun, ECRIS2018-TUA5, Catania, Italy, 2018

● High intensity Metal Beams – Why is Uranium so challenging?

- Uranium Vapor: Very high oven temperatures are needed to produce sufficient U flux into the plasma: 1900 °C to 2200 °C

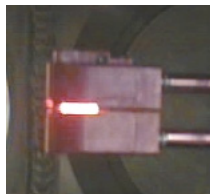

- High magnetic field at the oven location

- Reliability of the oven under these conditions (chemical reactions at high temperature, material fatigue)

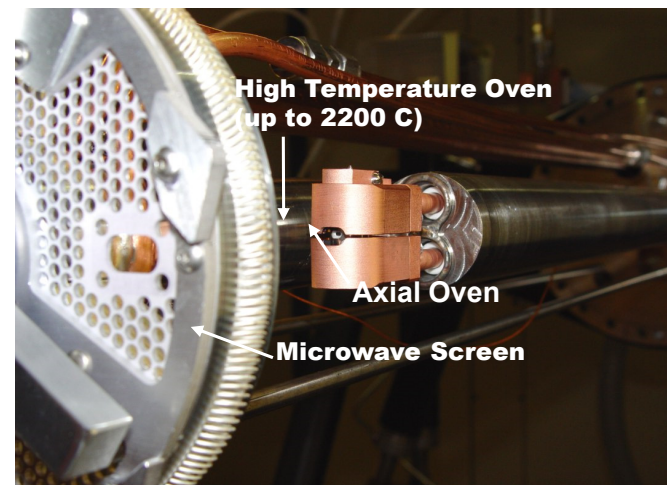

Materials tested at LBNL

UF₆	High charge state ion performance terrible
U	Yttria crucibles, liquid - corrosive
URe ₂	Works well in Re, Ta, W ovens, but not commercially available (1800- 2000 °C)
UO ₂	Works well, readily available, 2-3 weeks production run completed in LBNL and RIKEN – Rhenium Oven (2000- 2300 °C)

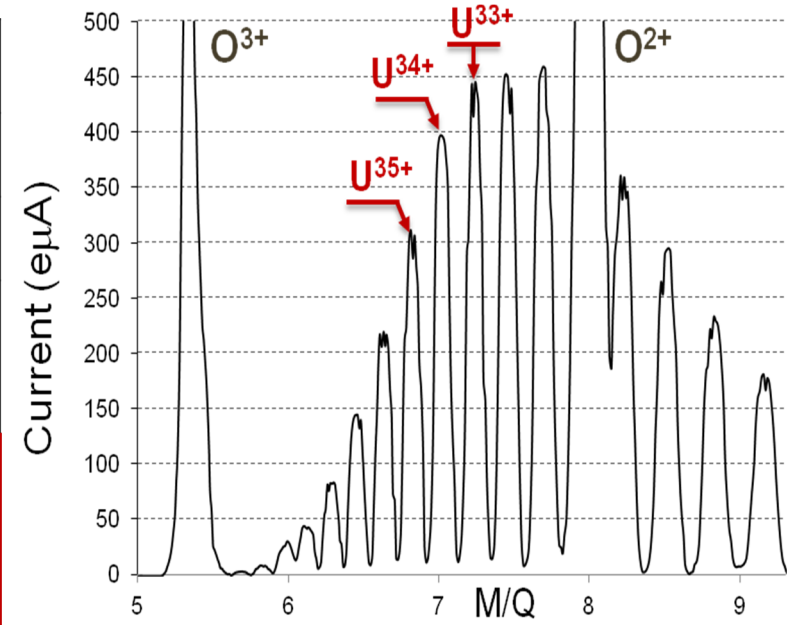

Strong Magnetic Field At The High Temperature Oven Location Results In Challenging Design Conditions

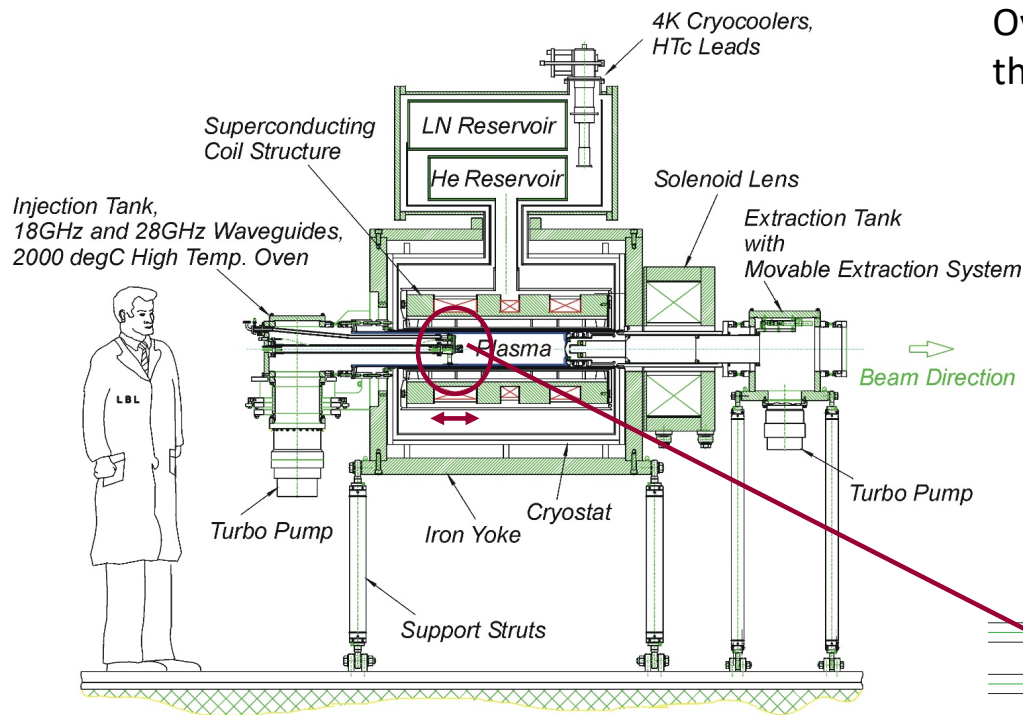

Oven is located close to the peak of the mirror field

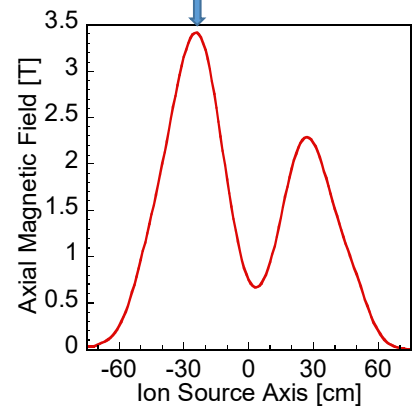

Force limits the temperature that can be achieved reliably in operation

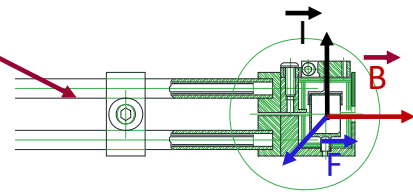

$F=I \times B$
 300A, 4T
 2.5cm length, 30N

Possible solution: Use of AC heating currents – needs to be tested and optimized

Possible Solution Is A Coaxial Oven: The Heater Current Flow Is Parallel To The Magnetic Flux Lines

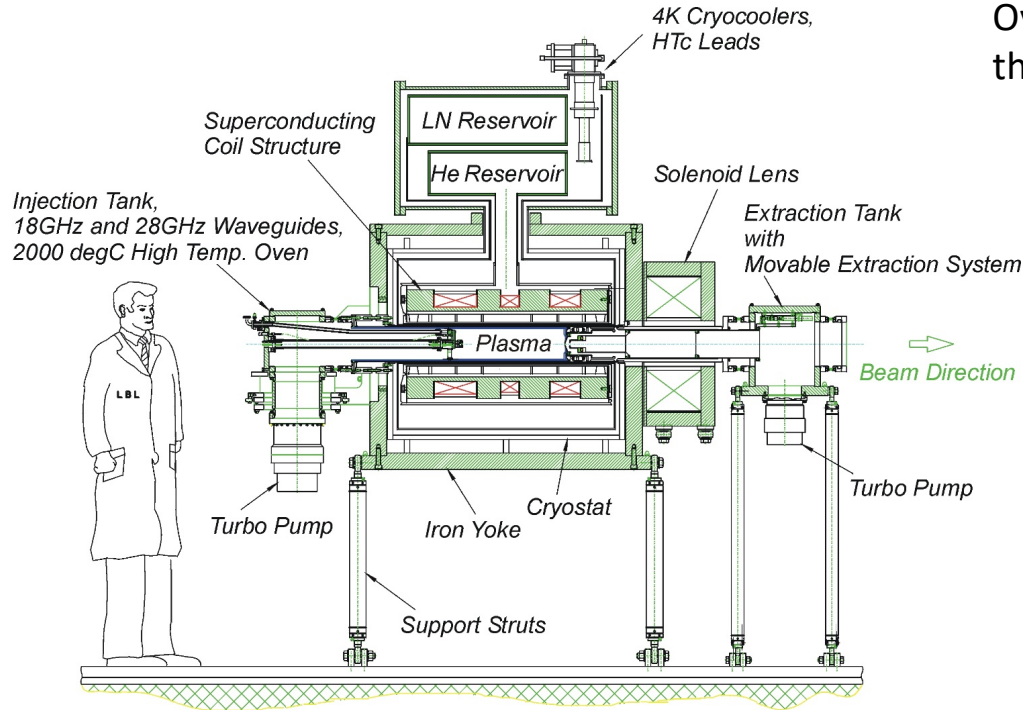

Oven is located close to the peak of the mirror field

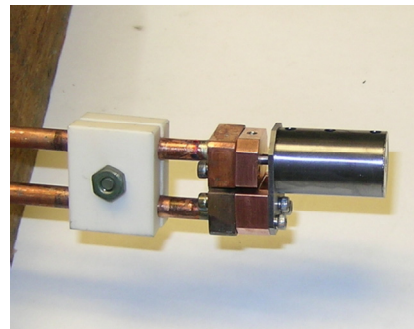
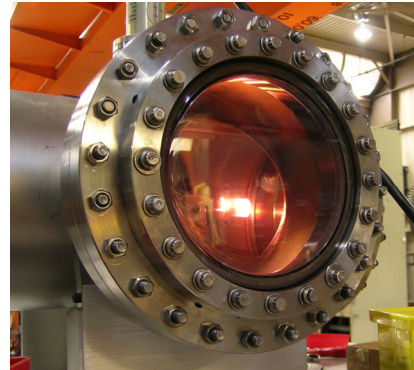
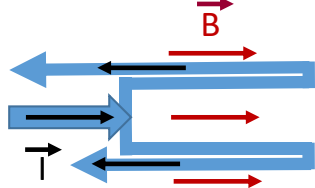
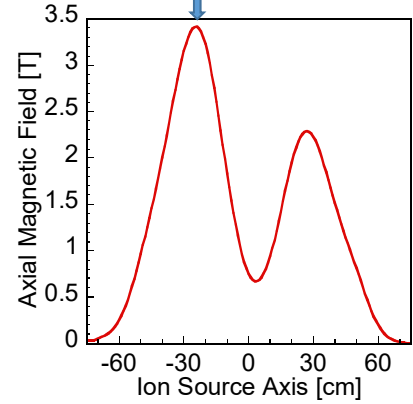

Needs testing and development to achieve the reliability required for operations

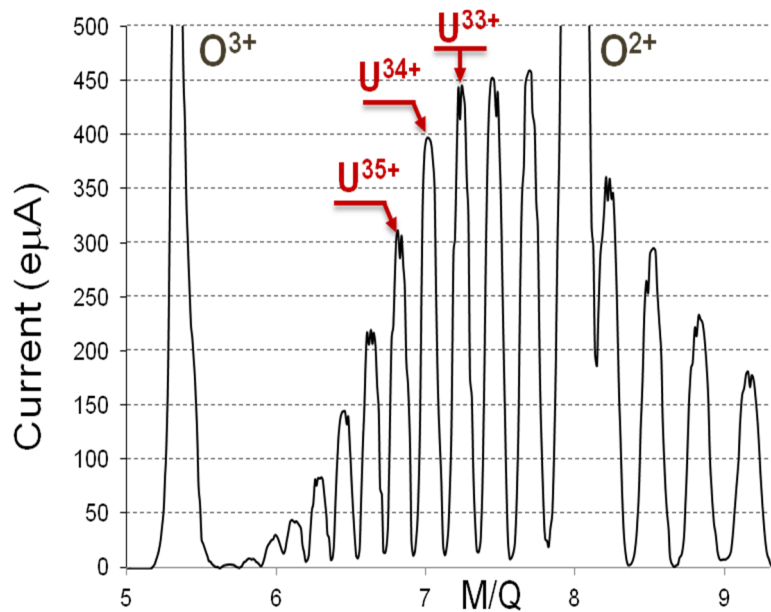

Demonstrated source performances and improvements show that next generation accelerator performance requirements are in reach, but challenges remain

Beams (eµA)	VENUS * 28+18 GHz (2018, 10 kW)	SECRAL I+II** 24+18 GHz (2018, 10 kW)	Required Intensities (eµA)
O ⁶⁺	4750	6700	> 400
O ⁷⁺	1900	1750	> 400
Ar ¹²⁺	1060	1420	> 1000
Ar ¹⁷⁺	115	133	
Xe ²⁷⁺	705	920	> 500
Xe ³⁸⁺	26	N/A	
Bi ³⁰⁺	310	710	>650
Bi ⁶¹⁺	0.1	N/A	
^o U ³²⁺	450	200	>500
^o U ³⁵⁺	300	N/A	>500
U ⁴⁷⁺	5	N/A	>1000

*Dan Xie, ECRIS2018-MO02, Catania, Italy, 2018

^oJanilee Benitez, ECRIS2012, Sydney, Australia, 2016

**Liangting Sun, ECRIS2018-TUA5, Catania, Italy, 2018

Uranium Medium Charge States*

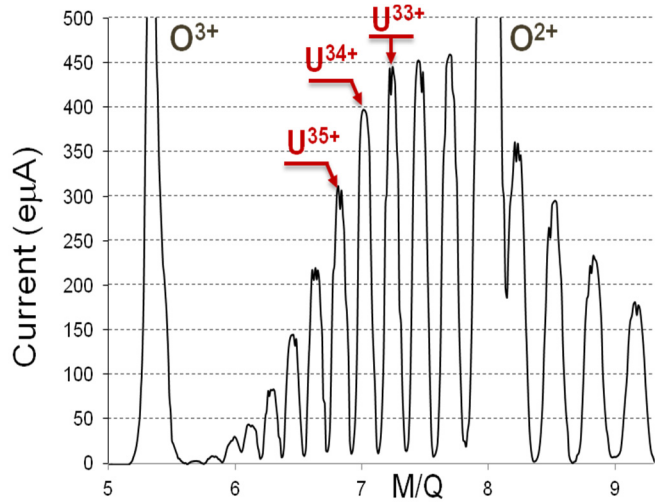

Uranium High Charge States

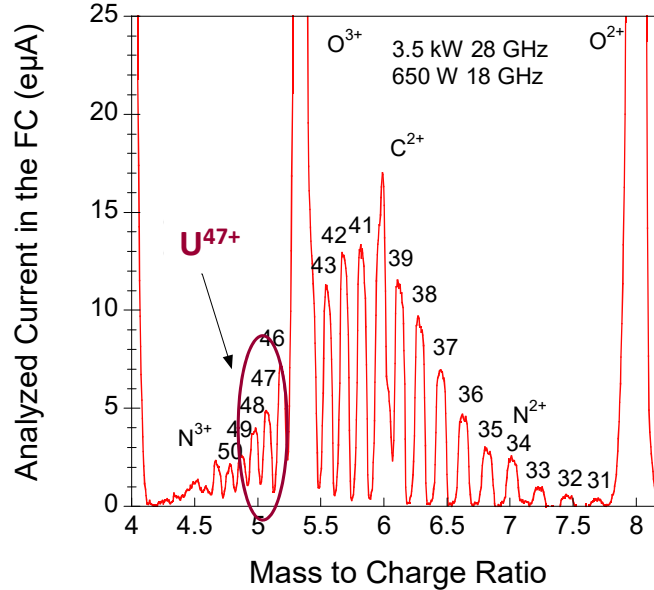

Heavy Ion Research Facility (HIRFL), Lanzhou China

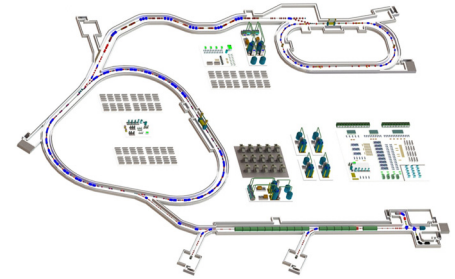

1000 eµA (U³⁵⁺ - U⁴⁶⁺)

VENUS Performance: 450 eµA U³³⁺, 10 eµA U⁴⁶⁺

Increasing Both Magnetic Fields And Frequencies Are The Key To Improved Performance



$$n_e \propto \omega_{rf}^2 \propto I$$

Beam Current

$$q_{opt} \propto \log B^{3/2}$$

Average Charge State

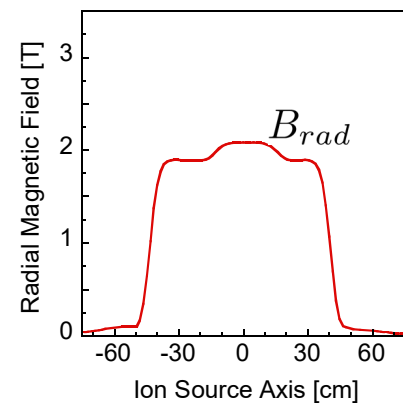
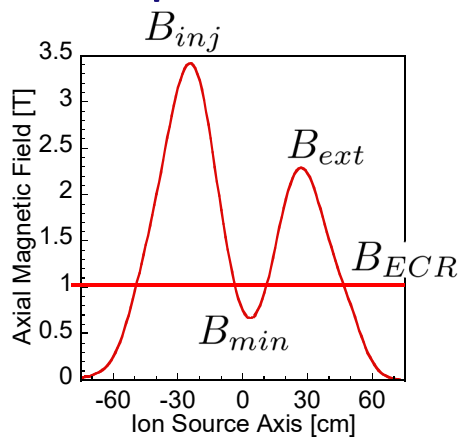

20 eμA Ar¹²⁺

200 eμA Ar¹²⁺

ECR (1983)
0.4 T, 0.6 kW, 6.4 GHz

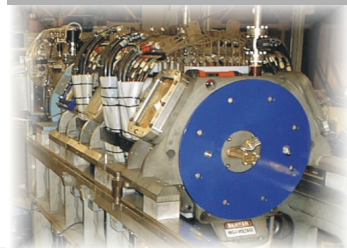

AECR-U (1996)
1.7 T, 2.6 kW, 10 + 14 GHz

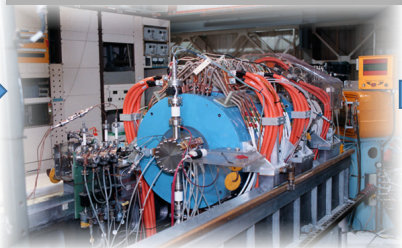

VENUS (2001)
4.0 T, 14 kW, 18 + 28 GHz



4th Generation (2025?)
6-8 T, 30 kW, >45 GHz

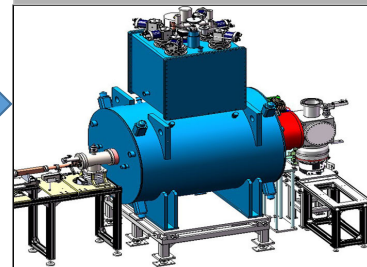

NORMAL CONDUCTING

Increasing Both Magnetic Fields And Frequencies Are The Key To Improved Performance



$$n_e \propto \omega_{rf}^2 \propto I$$

Beam Current

$$q_{opt} \propto \log B^{3/2}$$

Average Charge State

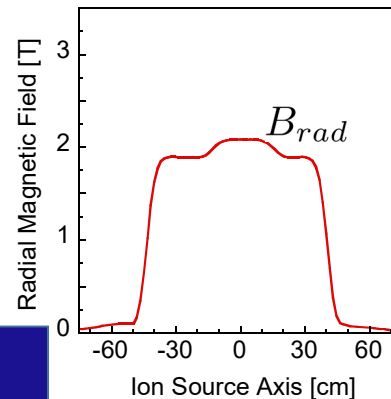
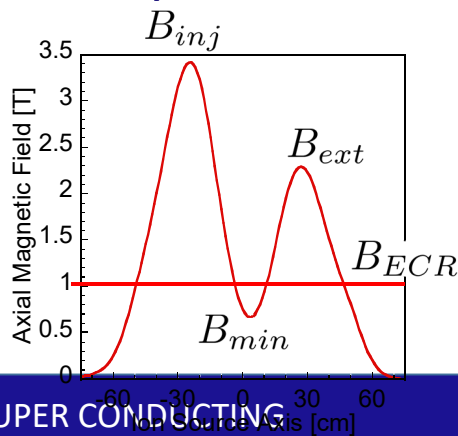

SUPER CONDUCTING

20 eμA Ar¹²⁺

200 eμA Ar¹²⁺

1000 eμA Ar¹²⁺

3000 eμA Ar¹²⁺ ?

ECR (1983)
0.4 T, 0.6 kW, 6.4 GHz

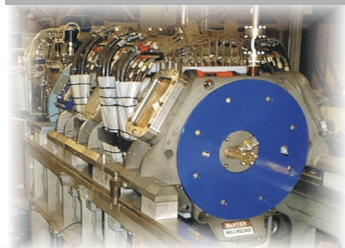

AECR-U (1996)
1.7 T, 2.6 kW, 10 + 14 GHz

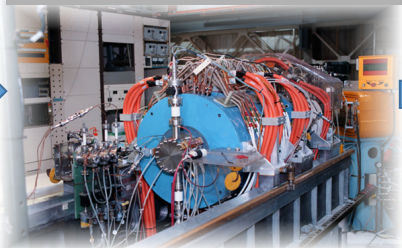

VENUS (2001)
4.0 T, 14 kW, 18 + 28 GHz

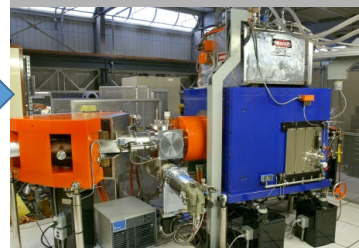

4th Generation (2025?)
6-8 T, 30 kW, >45 GHz

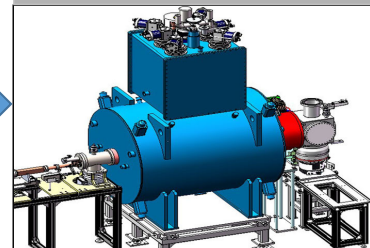

NORMAL CONDUCTING

SUPER CONDUCTING

Increasing Both Magnetic Fields And Frequencies Are The Key To Improved Performance

$$B_{inj}/B_{ECR} = 4$$

$$B_{ext} \approx 0.9 \text{ to } 1.2 B_{rad}$$

$$B_{rad}/B_{ECR} = 2$$

$$0.4 < B_{min}/B_{ECR} < 0.8$$

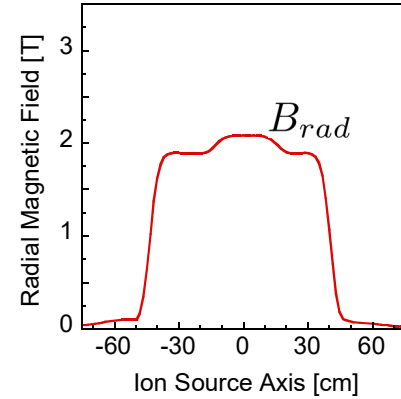
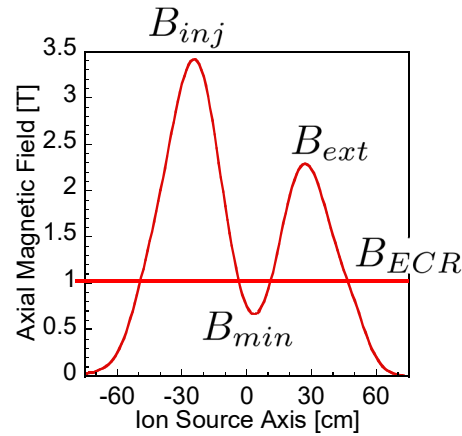

ECR (1983)
0.4 T, 0.6 kW, 6.4 GHz

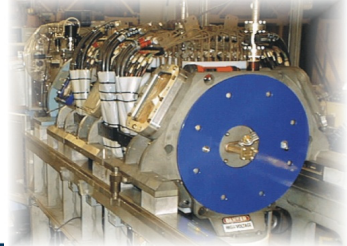

AECR-U (1996)
1.7 T, 2.6 kW, 10 + 14 GHz

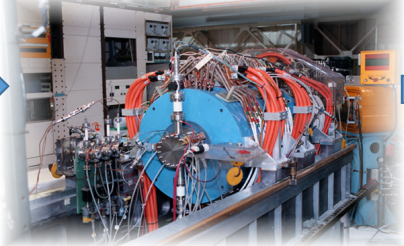

VENUS (2001)
4.0 T, 14 kW, 18 + 28 GHz

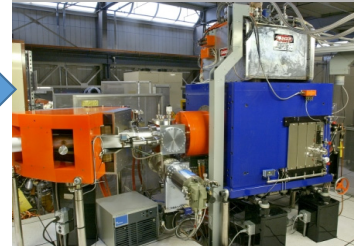

4th Generation (2025?)
6-8 T, 30 kW, >45 GHz

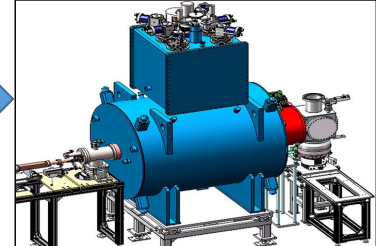

NORMAL CONDUCTING

SUPER CONDUCTING

Increasing Both Magnetic Fields And Frequencies Are The Key To Improved Performance

$$B_{inj}/B_{ECR} = 4$$

$$B_{ECR}(T) = \frac{F_{rf}(GHz)}{28(GHz)} \cdot T$$

$$B_{ext} \approx 0.9 \text{ to } 1.2 B_{rad}$$

$$B_{rad}/B_{ECR} = 2$$

$$0.4 < B_{min}/B_{ECR} < 0.8$$

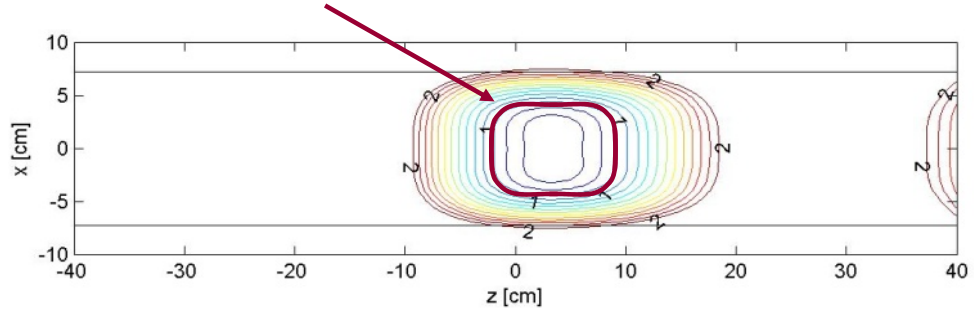

ECR (1983)
0.4 T, 0.6 kW, 6.4 GHz

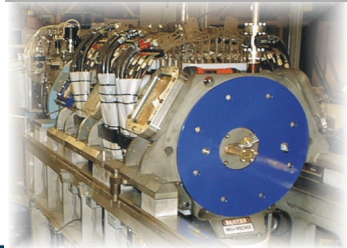

AECR-U (1996)
1.7 T, 2.6 kW, 10 + 14 GHz

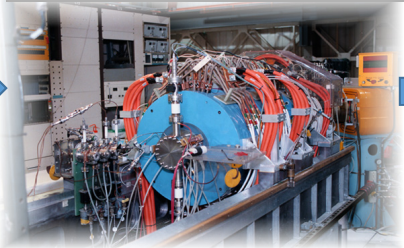

VENUS (2001)
4.0 T, 14 kW, 18 + 28 GHz



4th Generation (2025?)
6-8 T, 30 kW, >45 GHz

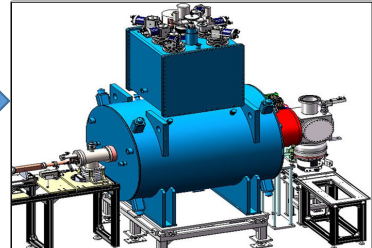

NORMAL CONDUCTING

SUPER CONDUCTING

Two geometries have been successfully realized to create the min-B field

Sextupole-in-Solenoid Classic Geometry
(VENUS, VENUS II, SC-28 RIKEN I+II, SuSI)

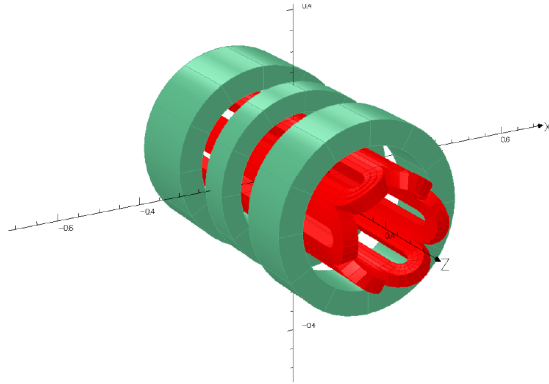

- Minimizes the peak fields at the coils
- Strong influence (forces) of the solenoid field on the sextupole ends

Solenoid-in-Sextupole Geometry
(SECRAL I, SECRAL II)

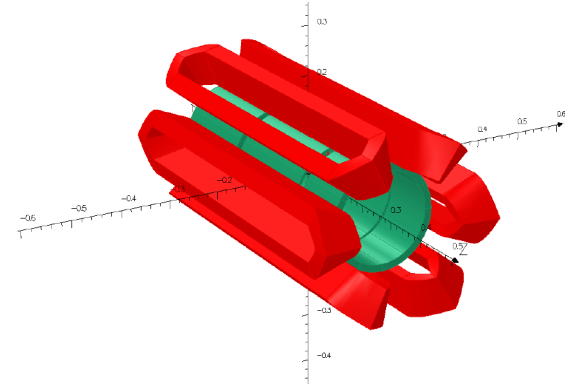

- Minimizes the influence of the solenoid on the sextupole field
- Significantly higher field required for the sextupole magnet due to the larger coil radius
- Strong forces on the solenoid coils

Superconducting Magnets: ECR Design Rules

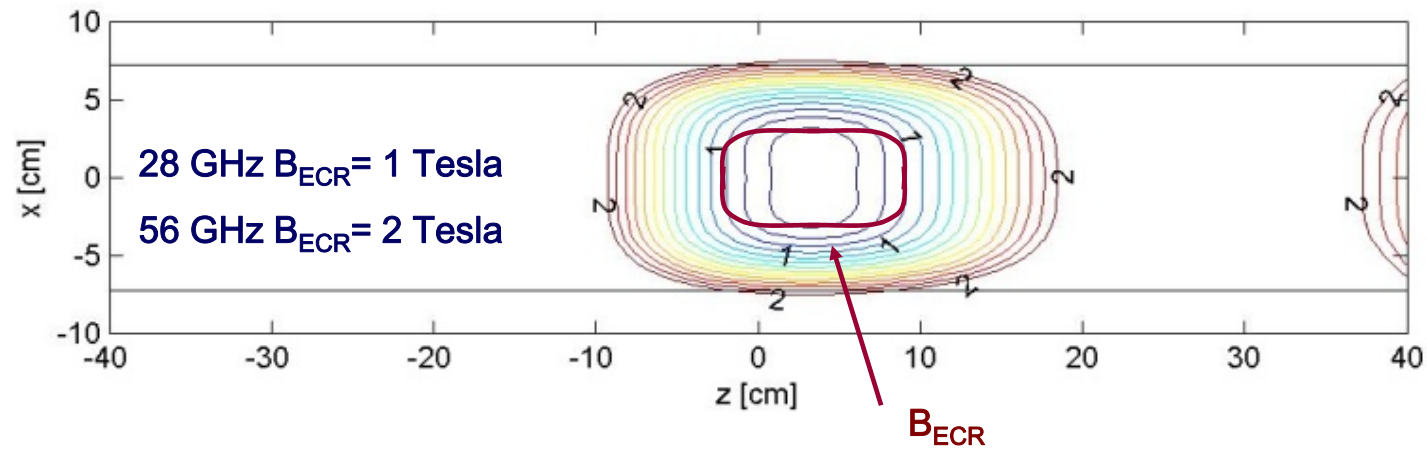

	28 GHz	56 GHz
$B_{inj} \sim 4 \cdot B_{ecr}$	4T	8T
$B_{min} \sim 0.8 B_{ecr}$.5-.8 T	1-1.6 T
$B_{ext} \sim B_{rad}$	2T	4T
$B_{rad} \geq 2 B_{ecr}$	2T	4T

Magnetic Design		28 GHz	56 GHz
Max solenoid field	on the coil	6 T	12 T
	on axis	4 T	8 T
Max sextupole field	on the coil	7 T	15 T
	on plasma wall	2.1 T	4.2 T
Superconductor		NbTi	Nb ₃ Sn

Sextupole-in-Solenoid Classic Geometry

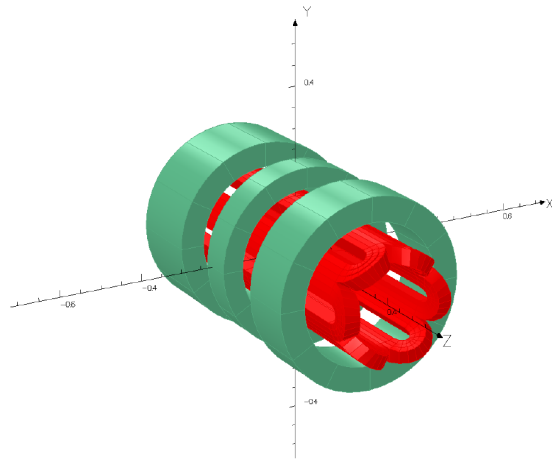

- Minimizes the peak fields in the coil
- Strong influence (forces) of the solenoid field on the sextupole ends

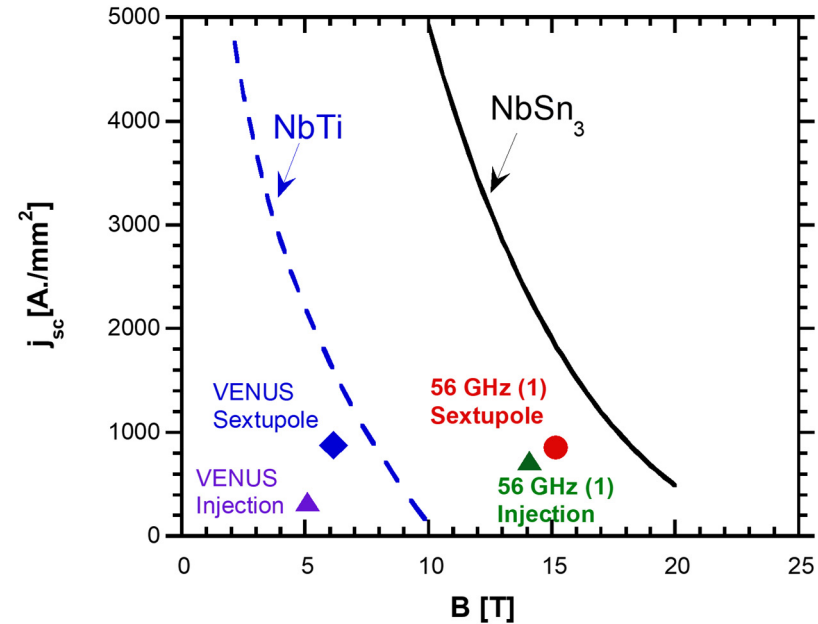

P. Ferracin et al., Rev. Sci. Instrum., vol.81, 02A309 (2010)

45 GHz ECR Magnet Design has been developed in a collaboration between LBNL and IMP

FECR Magnetic Design *

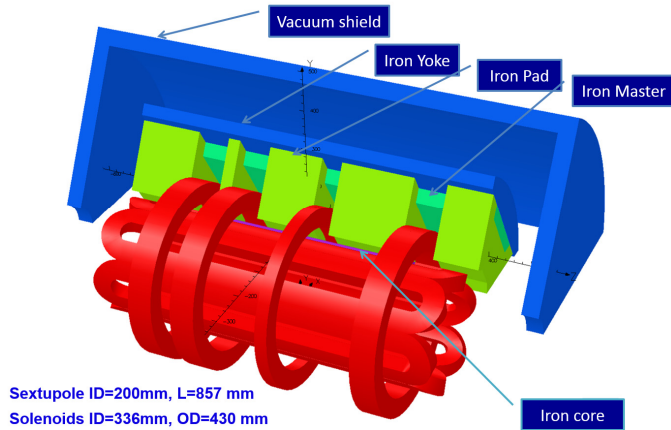

FECR Nb3Sn magnet mechanical structure**

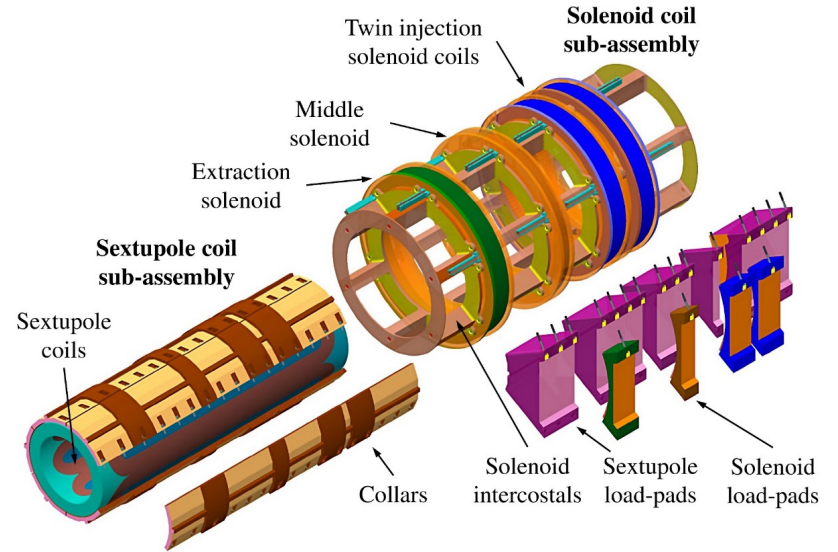

R&D/ Prototype Phase

*H.W. Zhao et.al ECRIS2018, Catania, Italy, 2018

*H.W. Zhao et. al., Rev. Sci. Instrum., vol.89, 052301 (2018)

**M. Juchno et al., IEEE Trans. Appl. Supercond., 28, 4602806(2018)

45 GHz ECR Magnet Design has been developed in a collaboration between LBNL and IMP

Design is based on several years of experience with the design and fabrication Nb₃Sn at LBNL within the LARP program and the HILUMI project to develop high field quadrupoles (Rutherford Cables) for the LHC upgrade.

Challenges:

- Combined magnet functionality (Solenoid and Sextupole)
- Single Strand SC Wire

FECR Nb3Sn magnet mechanical structure**

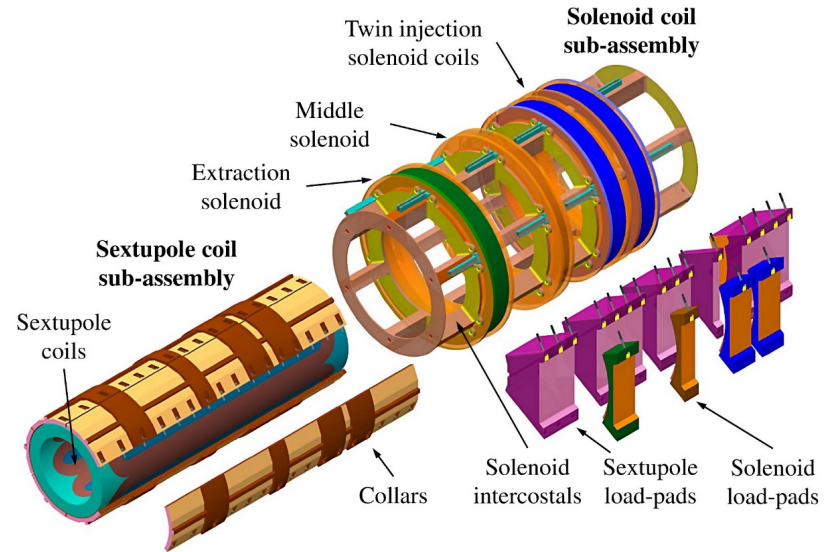

Technology is within reach in the next 5-10 years

*H.W. Zhao et.al ECRIS2018, Catania, Italy, 2018

*H.W. Zhao et. al., Rev. Sci. Instrum., vol.89, 052301 (2018)

**M. Juchno et al., IEEE Trans.Appl.Supercond., 28, 4602806(2018)

High critical current density and operation at $T > 4\text{K}$ makes HTS materials an attractive candidate for frequencies beyond 56 GHz

32 T all superconducting solenoid was recently developed

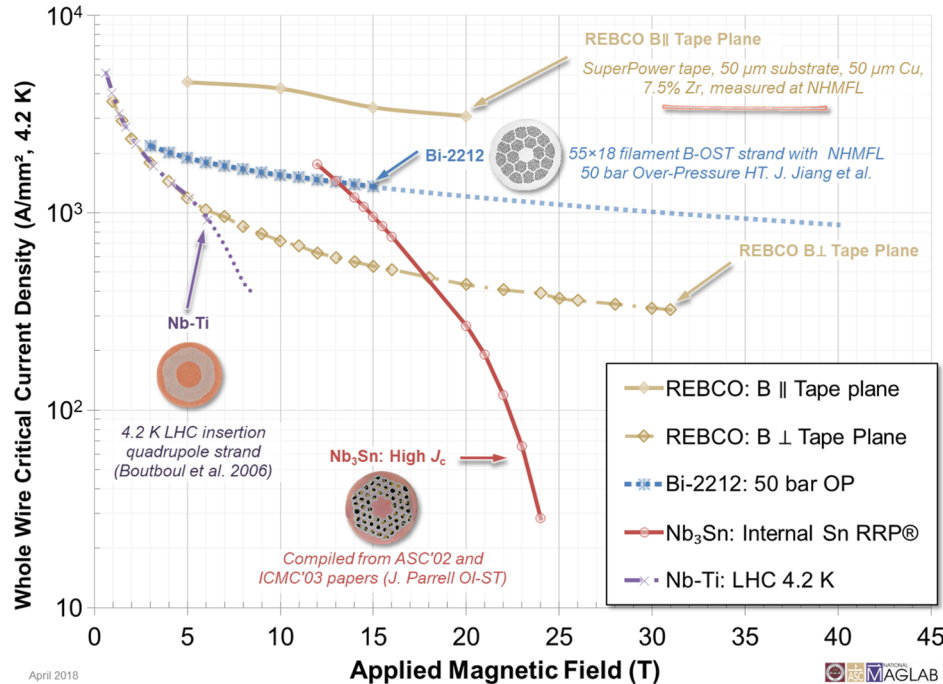

40 mm

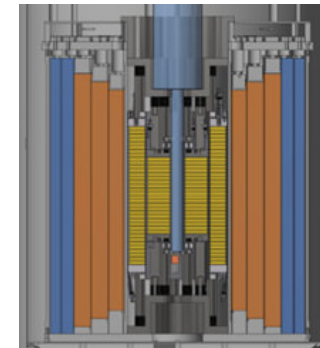

Nb-Ti, Nb₃Sn, REBCO

S. Hahn, Supercond. Sci. Technol. 21, 105017 (2016)

High critical current density and operation at $T > 4\text{K}$ makes HTS materials an attractive candidate for frequencies beyond 56 GHz

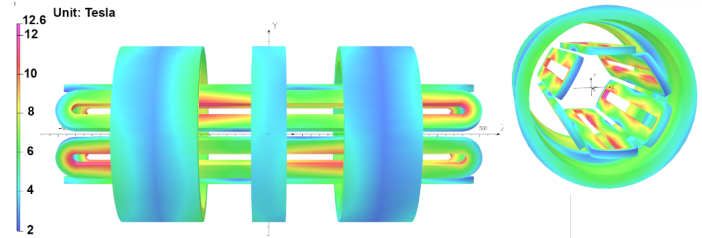
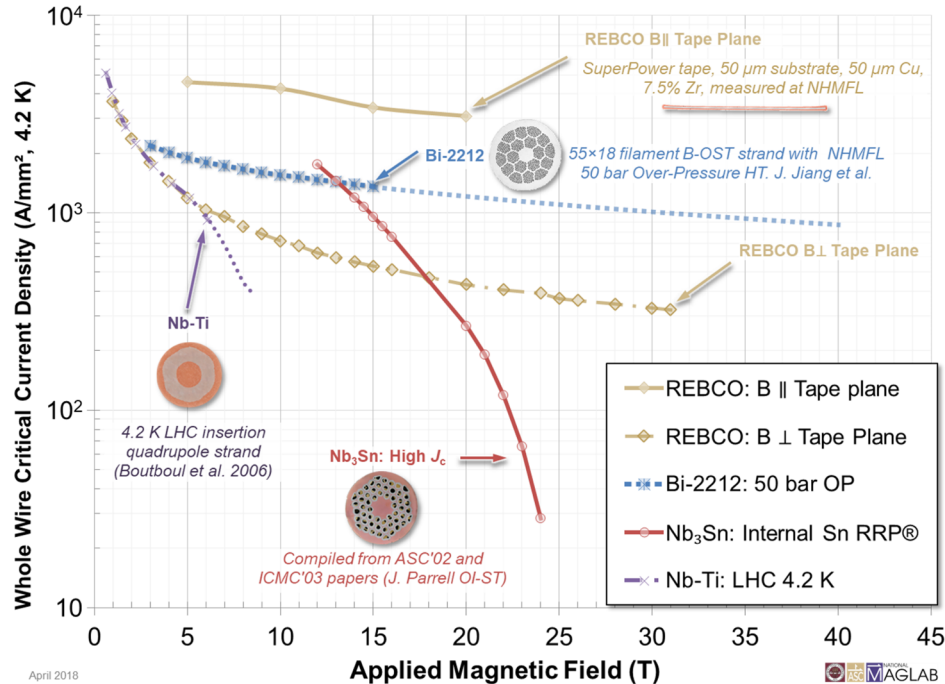

T. Shen, et al., ECRIS'18, Catania, Italy, (2018)

Technology is within reach in the next 10-15 years

S. Hahn, Supercond. Sci. Technol. 21, 105017 (2016)



- ECR ion source performance continues to improve for 3rd Generation ECR ion sources
- Technological challenges remain for high power operation of these sources and the production of high temperature, high intensity heavy ion beams (Uranium)
- The ion beam intensities needed for future heavy ion facilities require development of 4th and 5th generation ECR ion sources
- Nb₃Sn structures are the most promising candidates for building ECR magnets to be operated using microwave frequencies beyond 45 -56 GHz
- HTS technology is emerging as a promising option for 5th Generation ECR magnet structures for operations beyond 56 GHz

- Thanks to my colleagues from the ECR community Liangting Sun (IMP), Hongwei Zhao(IMP) Guillaume Machicoane (FRIB), Takahide Nakagawa (RIKEN), Janilee Benitez (LBNL), Laura Garcia-Fajardo (LBNL), and Tengming Shen (LBNL) from the ECR community to provide input, results and slides for this brief overview.

