

# **IPAC 2017**

## **Copenhagen, Denmark, 2017 May 14-19**

### **REVIEW & PROSPECTS OF RF SOLID STATE POWER AMPLIFIERS (SSPA) FOR PARTICLE ACCELERATORS**

- Experience with the SOLEIL 352 MHz SSPA's
- R&D with SSPA's at SOLEIL
- Review of used or planned SSPA's in other facilities

**P. MARCHAND**

# SSPA principle

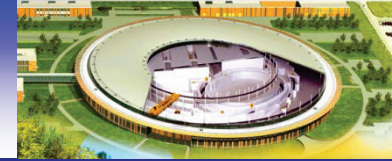

Combining in // a number of elementary amplifier modules (or pallets) of a few 100 W (up to ~ 1 kW)

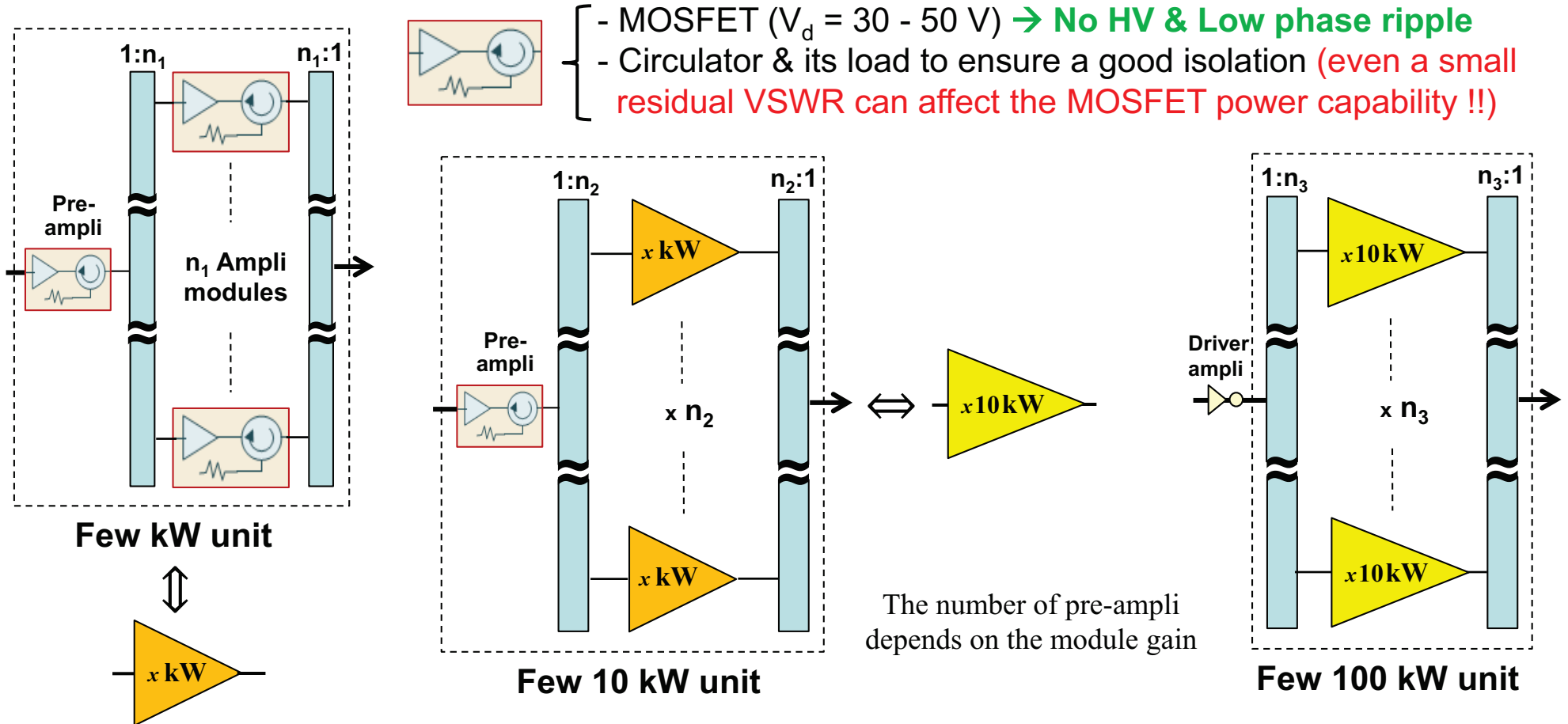

SOLEIL Booster SSPA ( $P_{\text{nom}} = 35 \text{ kW @ } 352 \text{ MHz}$ ) :

$P_{\text{mod}} \approx 300 \text{ W}$  ;  $n_1 = 8 \rightarrow 2.4 \text{ kW}$  ;  $n_2 = 8 \rightarrow 19 \text{ kW}$  ;  $n_3 = 2 \rightarrow 146 \text{ RF modules (128 Ampli + 18 Pre-A)} \rightarrow P_{\text{out}} \approx 38 \text{ kW}$

→ **Modularity & Redundancy inherent to such a design**



# 35 kW SSPA of the SOLEIL Booster

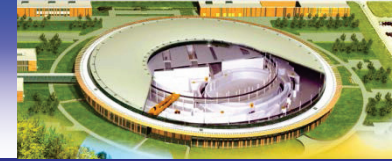

146 modules of 300 W @ 352 MHz & individual power supplies, mounted on 8 water cooled dissipaters

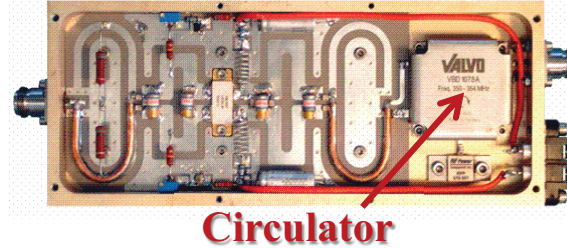
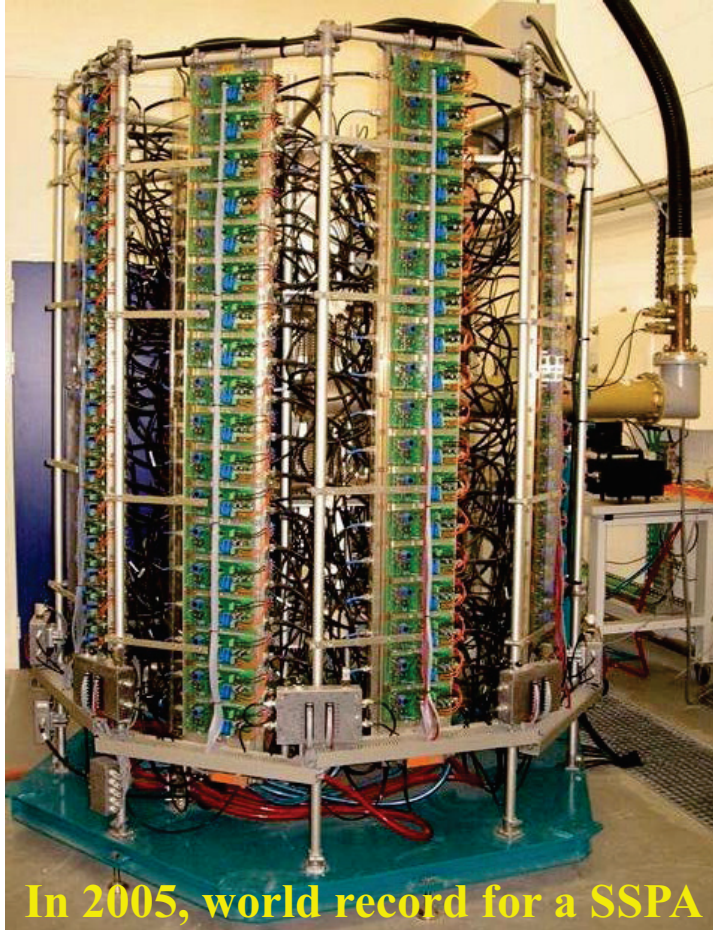

300 W CW - 352 MHz  
amplifier module  
**VDMOS D1029UK05**  
from SEMELAB  
( $G = 11$  dB,  $\eta = 62$  %)



600 W - 280 / 28 V dc  
power converter

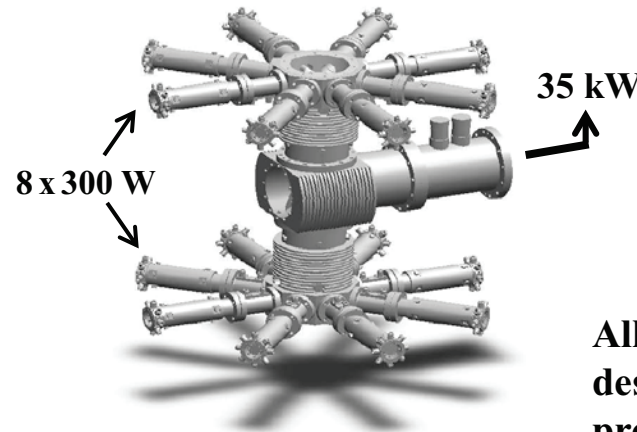

Power combiner  
(8 x 8 x 2)  
8 dissipaters of  
**16 + 2\*** modules  
\* **Pre-amplifiers**

All amplifier components were designed in house and the mass production contracted to industry

~ 65 000 running hours over 11 years and only a single trip from the SSPA, in August 2016, due to a loose connection on a monitoring cable (down time ~  $2 \cdot 10^{-5}$  and MTBF ~ 32 000 hours)  
~ 1 module failure / year, without impact on the operation, thanks to the modularity and redundancy



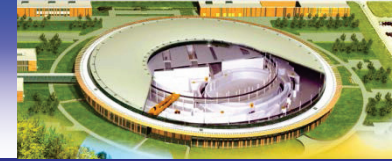

Based on the same principle as the BO one, extended to  
4 towers of 45 kW → 10 dissipaters of 18 modules per tower  
→ 726 modules / amplifier x 4 cavities → 16 towers & ~ 3000 modules

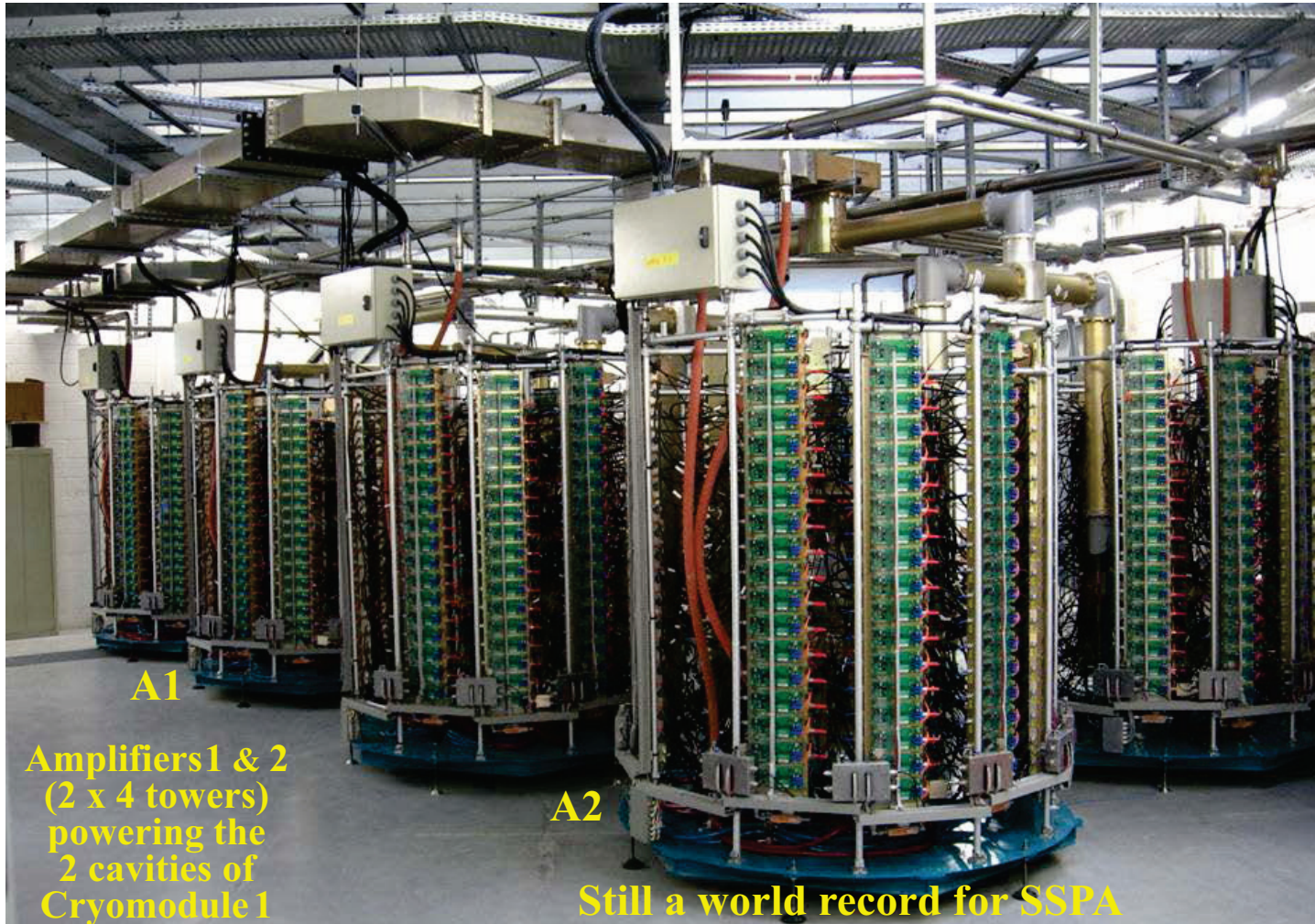

A1

Amplifiers 1 & 2  
(2 x 4 towers)  
powering the  
2 cavities of  
Cryomodule 1

A2

Still a world record for SSPA

LDMOS LR301 from POLYFET  
G : 13 dB,  $\eta$  : 62 %

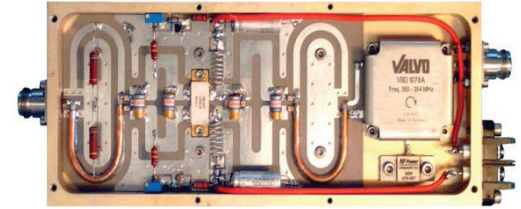

600 W - 280 Vdc / 28 Vdc

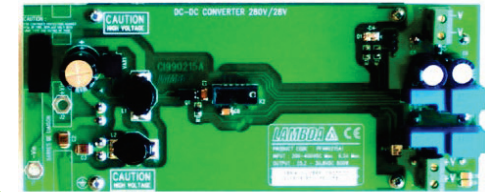

Splitters



Combiners





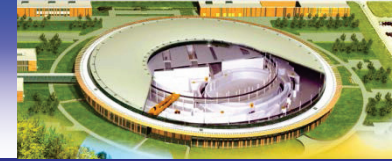

MTBF & beam downtime, cumulated by the 4 SR SSPA's over ~ 63 000 running hours in ~ 11 years

Equipment	MTBF	Downtime	Comments
a) 4 x RF amplifiers	~ 12 500 h	~ 1 10 <sup>-4</sup>	Preamplifier failures
b) 4 x 500 kVA thyristor-based 230 Vac/270 Vdc rectifiers	~ 8 000 h	~ 4 10 <sup>-4</sup>	Single rectifier per amplifier
a) + b) 4 x RF transmitters	~ 5 000 h	~ 5 10 <sup>-4</sup>	



**Already excellent MTBF and operational availability**  
**But still perfectible in providing some more redundancy**

- 1) in the ac-dc power conversion
- 2) in the preamplifier stage

→ Cures to both of these “weaknesses” were brought in our new design



**The failure rate of our original LR301 transistors remains significant, ~ 2% a year**  
**Thanks to the inherent redundancy, the operation is not affected (except for pre-ampli)**  
 It is mainly a matter of maintenance : ~ 5 k€ of material + 3 man.weeks / year  
 → Not so bad but can be largely improved using new generation LDMOS



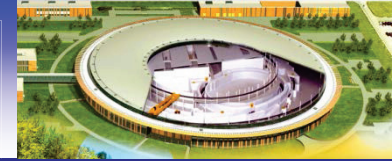

- In 2013, SOLEIL undertook to start replacing the original LR301 by 6<sup>th</sup> generation LDMOS (BLF574XR,  $V_d = 50V$  instead of 30V), much more robust and with higher gain (+7 dB)
  - More robust transistors → drastic reduction in module failures → less maintenance efforts
  - Higher power capability ( $P_{mod}: 310 W \rightarrow 450 W$ ) → storing full  $I_{beam}$  with only 3 running SSPA's
  - Electrical power savings (efficiency : 50 % → 60%) compensate the investment cost in < 3 years
- The 4 towers of Amplifier\_1 are already refurbished → go on at a rate of 2 towers a year
  - Not yet a single failure of a « new » transistor (~ 3 years of operation)
- Cure the lack of redundancy in the pre-amplification stage → combiner-divider assembly

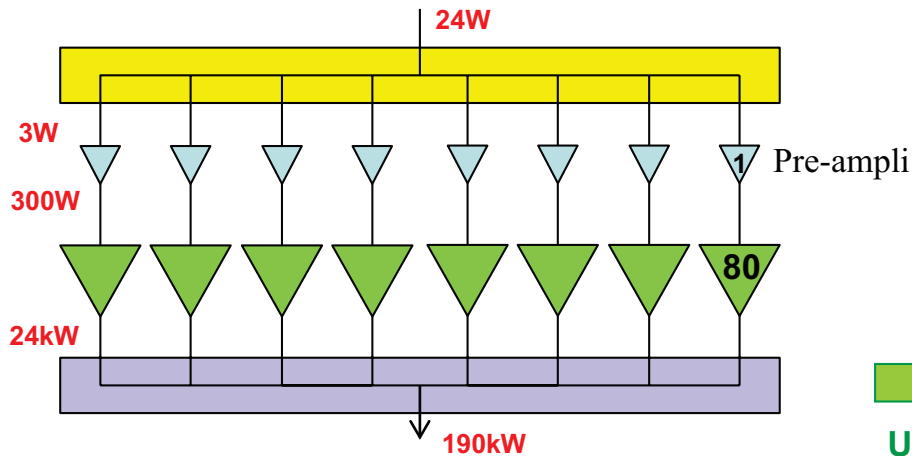

Previous config : each pre-ampli drives 80 modules;  
if one of them fails the amplifier is stopped

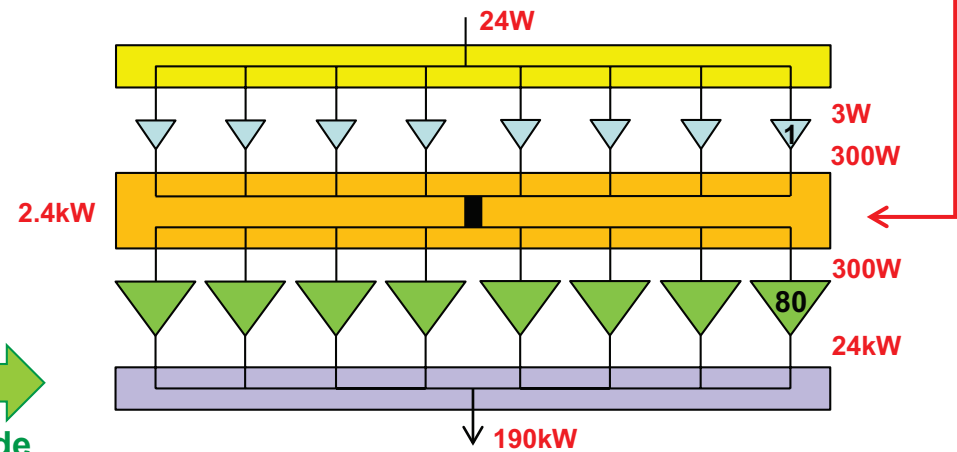

Thanks to the **combiner-divider**, the failure of a pre-ampli does not affect the functioning anymore



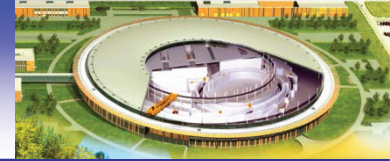

**In // to the activities on its equipment  
SOLEIL has carried on R&Ds with  
SSPA's → Scientific collaborations  
and transfers of technology**



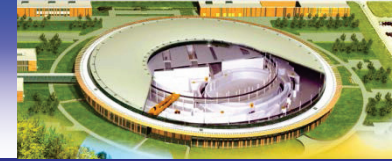

Development of new RF modules, based on 6<sup>th</sup> generation LDMOS ( $V_d = 50V$ )

→  $P_{mod} \sim 700 W$ ,  $G \sim 20 dB$ ,  $\eta > 70\%$  at 352 MHz

[ With original LR301 (28V),  $P_{mod} = 315 W$ ,  $G = 13 dB$ ,  $\eta = 62\%$  @ 352 MHz ]

→ Huge improvement :  $P_{mod} \times 2.2$ , better performance ( $G$ ,  $\eta$ , linearity)  
& strong reduction in thermal stress ( $\Delta T : -60^\circ C$ ) → longer lifetime



ESRF project of replacing its 1 MW klystrons by 150 kW SSPA's (1 per cavity)

→ 2009, SOLEIL transfer of technology with ELTA-AREVA

→ 7 SSPA's of 150 kW, built by ELTA under SOLEIL license

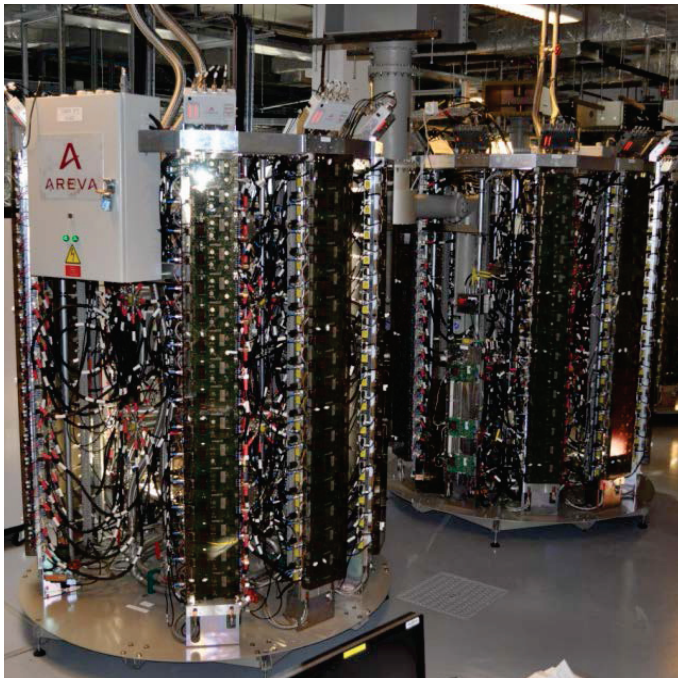

**ESRF 150 kW 352 MHz SSPA from ELTA/SOLEIL**  
2 towers of 75 kW ↔ 260 RF modules of 700 W

**BO : 4 x 150 kW SSPA's in use since January 2012**

2 trips in 5.5 years of operation → refill postponed

**SR : 3 x 150 kW SSPA's in use since October 2013**

2 trips in 3.5 years of operation → beam loss

Trips due to youth problems, which are now fixed

**BO + SR : ~ 1 820 transistors and not a single failure !**

**DC-to-RF efficiency of 58%, dc-dc converters included**  
*With new ac-dc converters →  $\eta$  (overall ac to RF) > 60%*



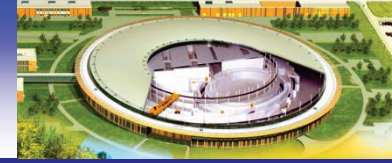

**Two SSPA's of 50 kW @ 476 MHz for LNLS (Brazilian LS) SR \*  
with components designed by SOLEIL (400 W modules with BLF574)**

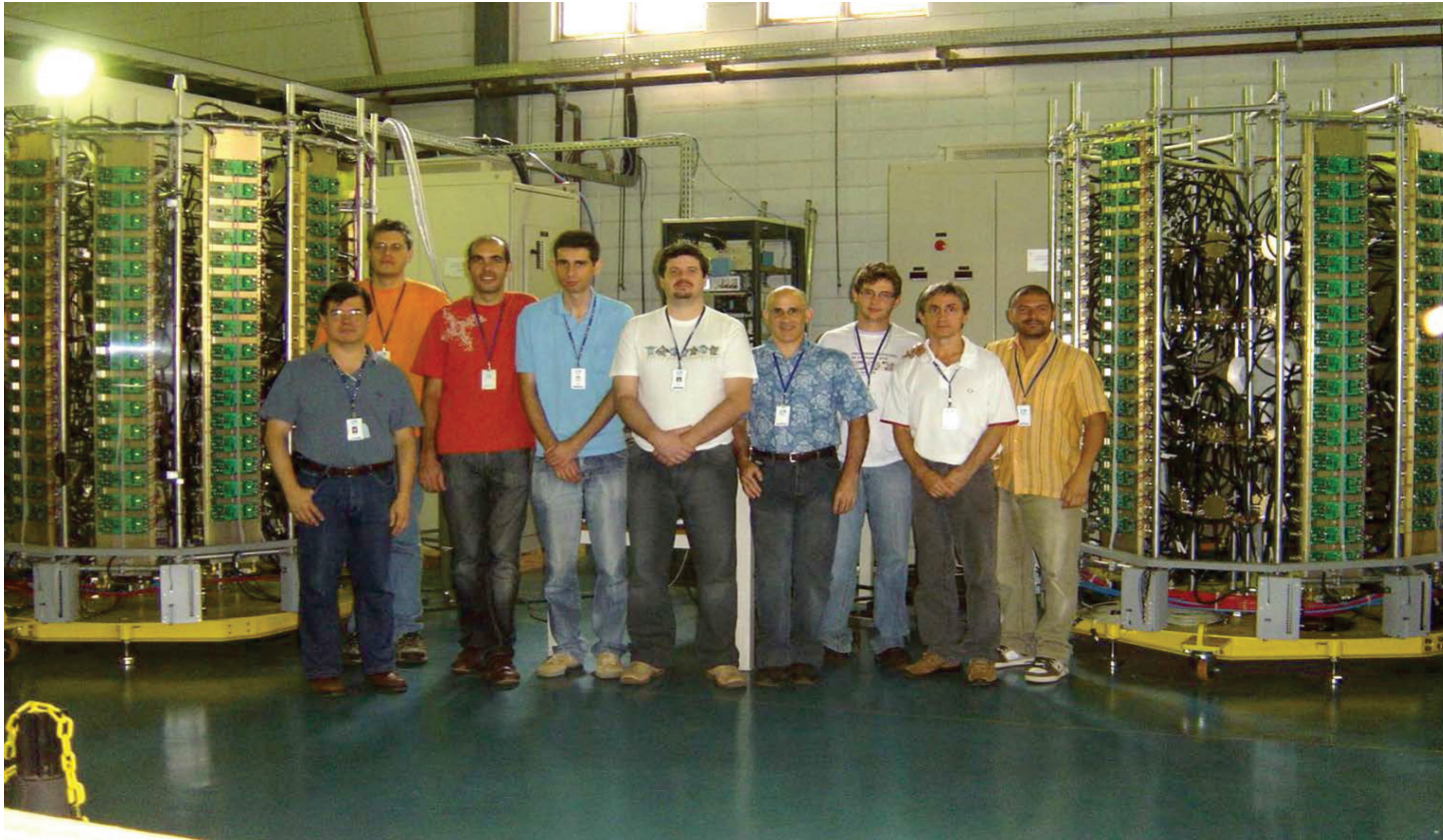

**April 2010 in Campinas-Brazil : the SOLEIL - LNLS team,  
after successful tests of the amplifiers**

*\* A 2.5 kW 476 MHz SSA had already been built for the LNLS Booster*



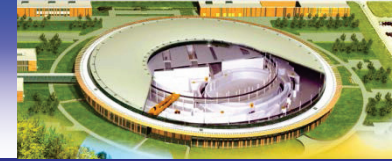

**The two 50 kW SSPA's of the LNLS SR have run satisfactorily for > 6 years  
→ Use of SSPA's @ 500 MHz in SIRIUS, the new LS under construction**



# 500 MHz SSPA for ThomX\* & SESAME†

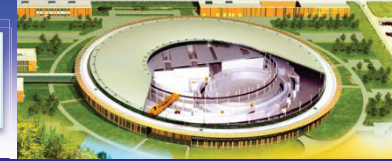

\* *ThomX* : Compton X-ray source under construction in Orsay, France

† *SESAME* : Synchrotron light source, which is being commissioned in Jordan



ThomX 50 kW SSPA (6 x 16 modules)

- Fully modular 50V power supplies  
230 V<sub>ac</sub> / 50 V<sub>dc</sub> converters, in 2 kW units, 96% efficiency, with voltage remote control  
→ optimized efficiency for any operating power :  
**56% (overall) @ P<sub>max</sub>**  
**~ 50% @ ½ P<sub>max</sub>**
- Change from the tower to cabinet assembly, better suited with the new power supplies.

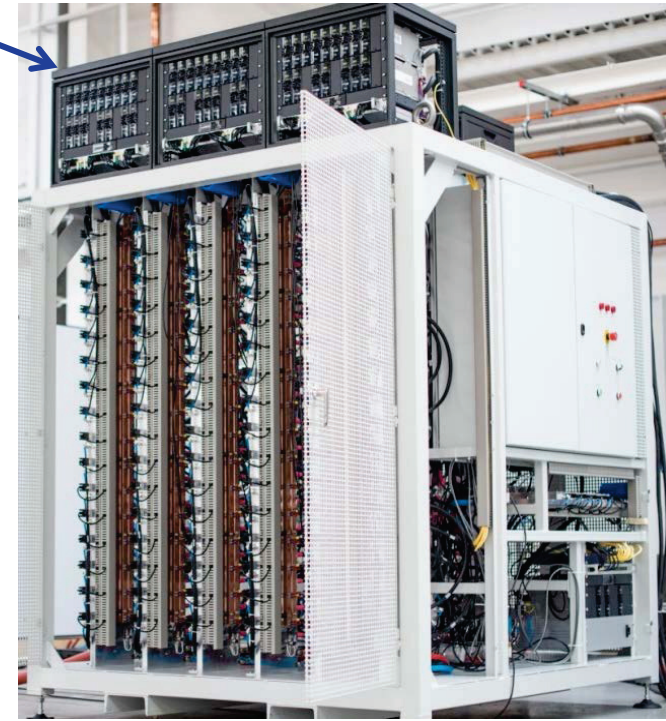

SESAME 80 kW SSPA (10 x 16 modules)

- ✓ **SESAME** needs 4 x 80 kW SSPA for its SR → 1<sup>st</sup> one built by SOLEIL as a demonstrator → 3 others on the same model by **SigmaPhi Electronics (SPE)**, SOLEIL licensee since 2014; two of them are operational in SESAME since end of last year and the second pair was successfully commissioned a few weeks ago.
- ✓ The ThomX 50 kW SSPA is also completed ; it shall be soon installed and commissioned on site.

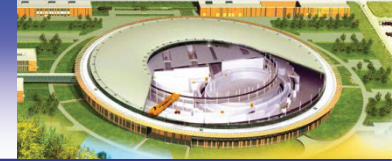

## **Non exhaustive review of used or planned SSPA's in other facilities, classified in 4 frequency ranges :**

- **UHF** {
  - **~ 350 & 500 MHz**
  - **L band (~ 1.3 GHz)**
  
- **VHF** {
  - **Radio FM (~ 100 MHz)**
  - **~ 200 MHz**



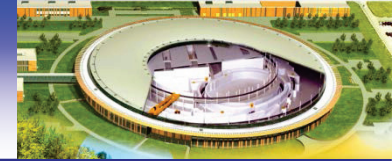

\* Swiss Light Source in Paul Scherrer Institut

Home made, following the SOLEIL design,  
except for its control system specificity

Commissioned in the SLS\* Booster a few months ago

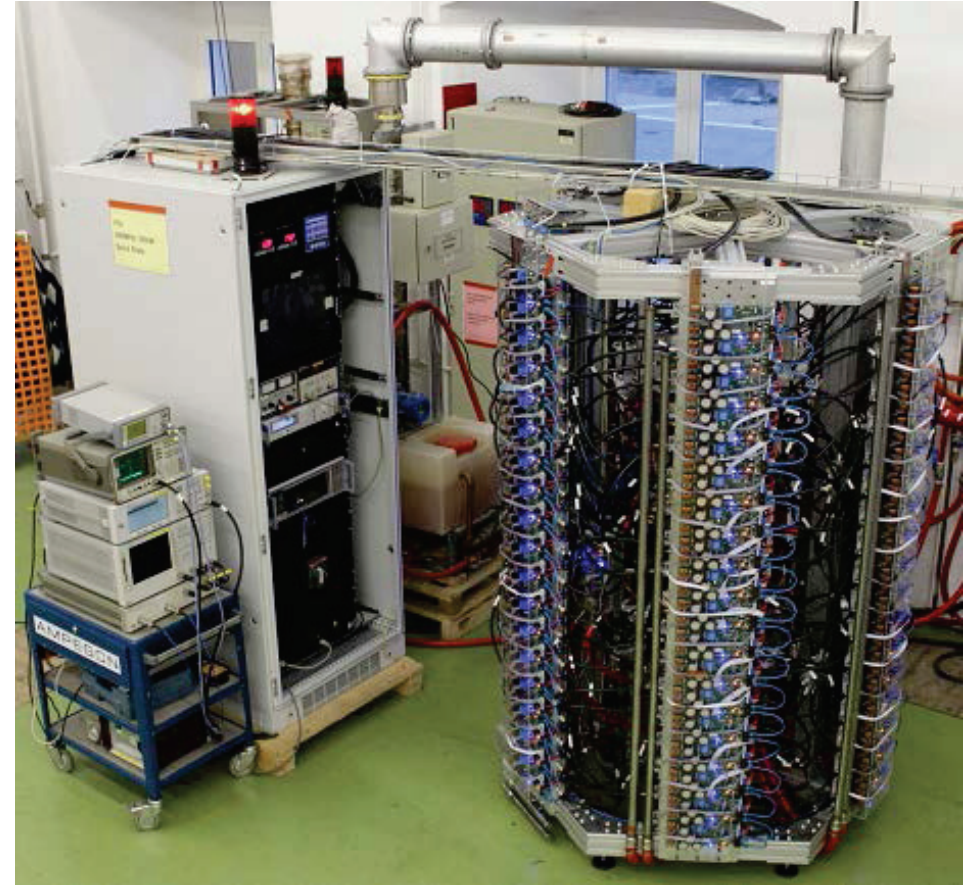
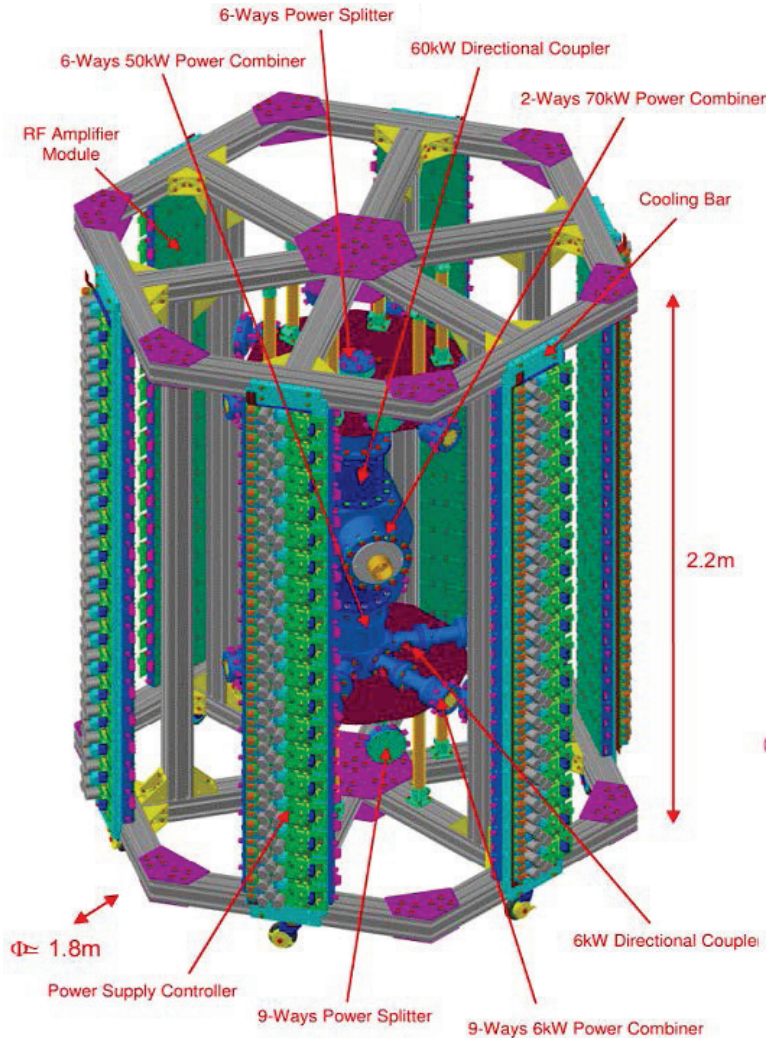

- ✓ 2.5 kW SSPA @ 352 MHz, built by LNL (Legnaro) → 10 kW for EURISOL
- ✓ 100 kW SSPA @ 508 MHz in Indus-2

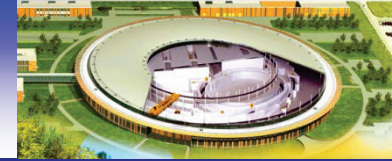

In BESSY II, all klystrons were recently replaced by 500 MHz SSPA's, 1 of 40 kW (Booster) + 4 of 75 kW (SR), supplied by Cryoelectra GmbH

10 dissipaters, each supporting  
13 modules of 600 W + 1 pre-A

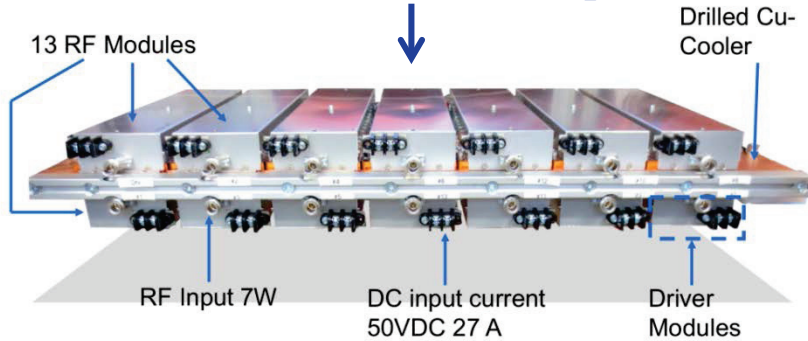

  
First stage :  
13 way coaxial  
combiner → 7.5 kW

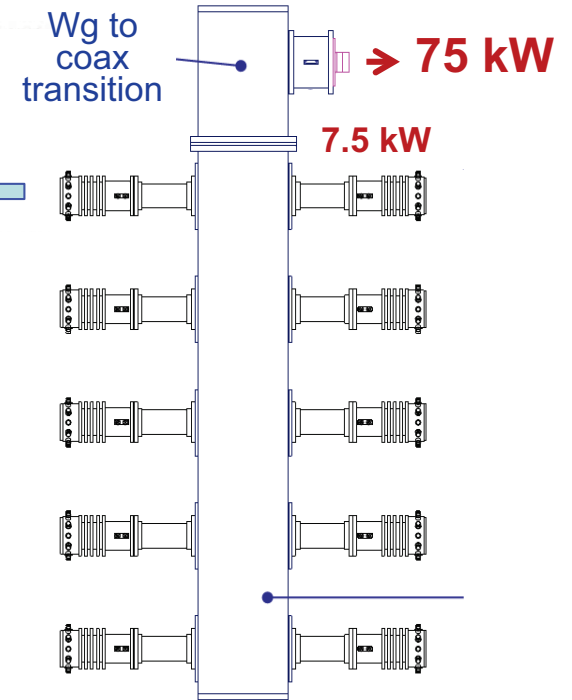

2<sup>nd</sup>e stage : 10 way coaxial  
to waveguide combiner



*One of the four 75 kW SR SSPA's in operation since end 2015 (efficiency ~ 50 %)*



# R&D with cavity combiner for 352 MHz SSPA's at ESRF

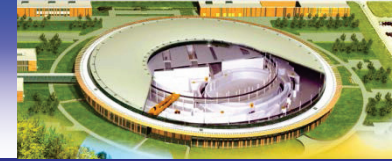

352 MHz 85 kW prototype

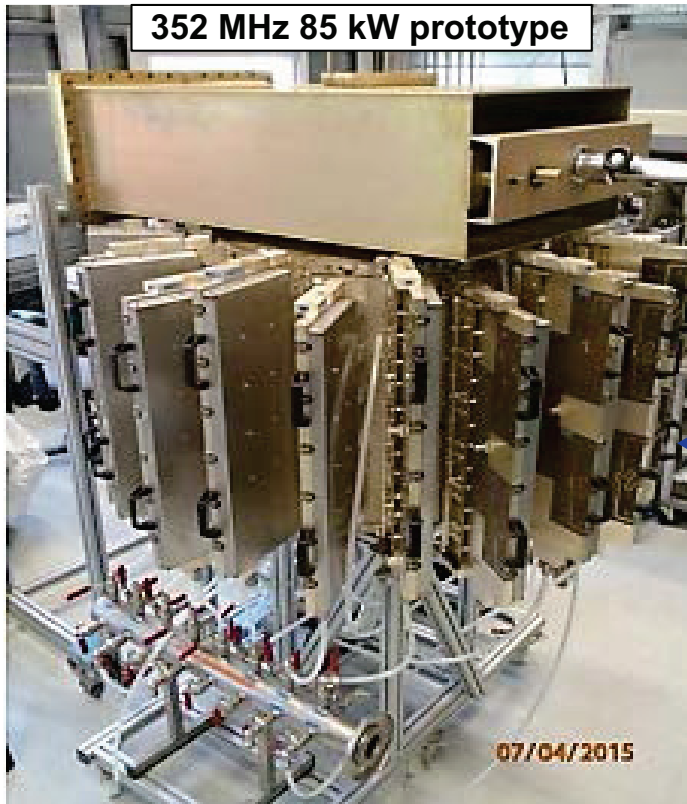

The cavity is made of 22 water cooled “wings”, on which are mounted 6 modules of  $\sim 700$  W, coupled to the cavity by means of loops, integral to the modules

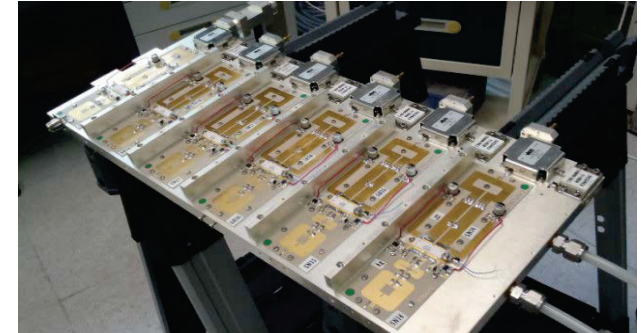

50 V PS (22 x 8 kW  $\leftrightarrow$  1/wing) hosted in a separate cabinet  
Prototype tested up to 85 kW with overall efficiency of  $\sim 56\%$

## PRO / CON

- (+) Eliminates RF power cables & quite compact
- (-) Coupling spread  $\rightarrow$  Individual sizing of the loops (position dependent)
- (-) It proved hard preventing the cavity from RF leakage
- (-) Tolerable VSWR lower than with a phase adjustable coaxial combiner



# R&D with cavity combiner for 200 kW 352 MHz SSPA's at APS

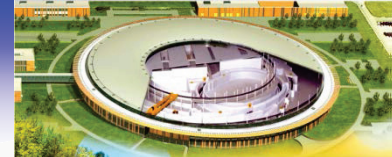

- Replace 1 MW - 352 MHz klystron amplifiers with 200 kW SSPA's
- **2 kW** LDMOS modules →
- 108 : 1 cavity combiner (18 wings of 6 modules)

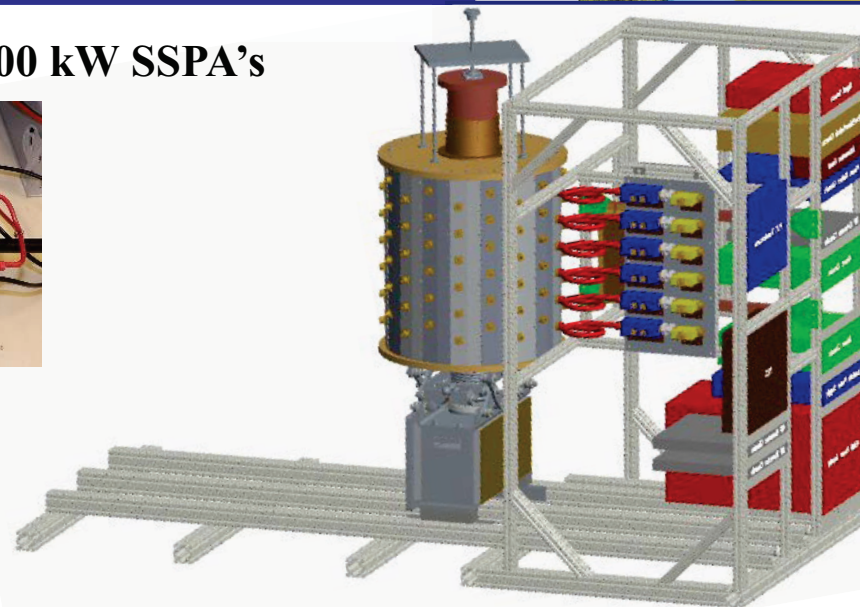
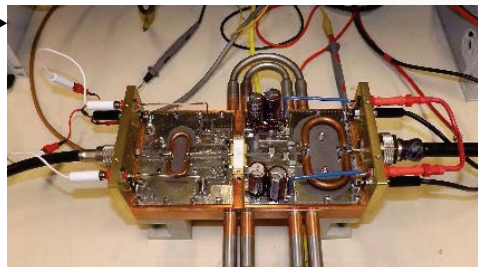

A demonstrator with the combining cavity and a single wing of 6 modules is under way

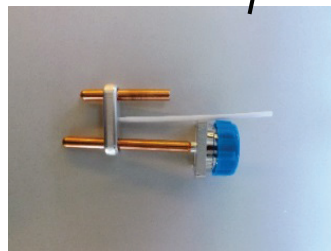
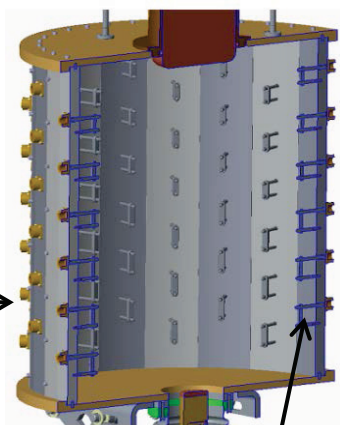
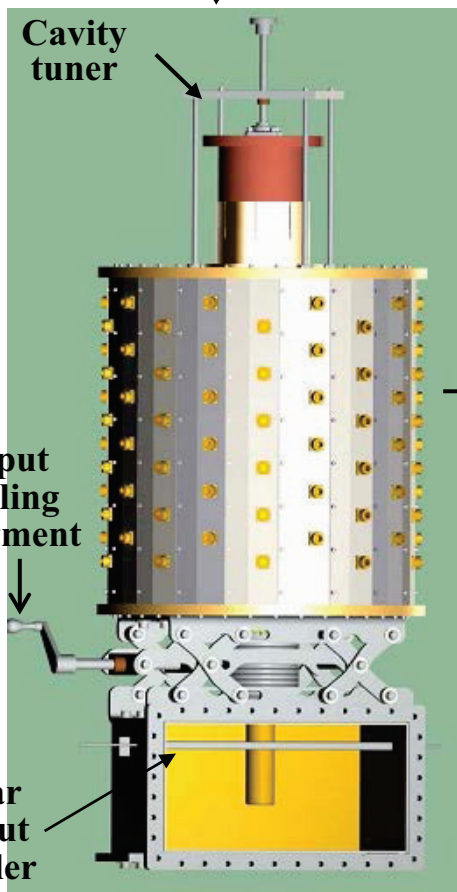

Input coupling loop, integral to the cavity & adjustable in area





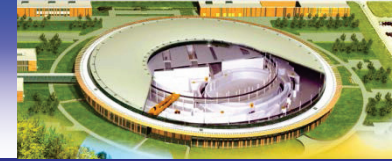

Future replacement of 1 MW - 509 MHz klystron amplifiers with 8 SSPA's of 110 kW (1/cavity)

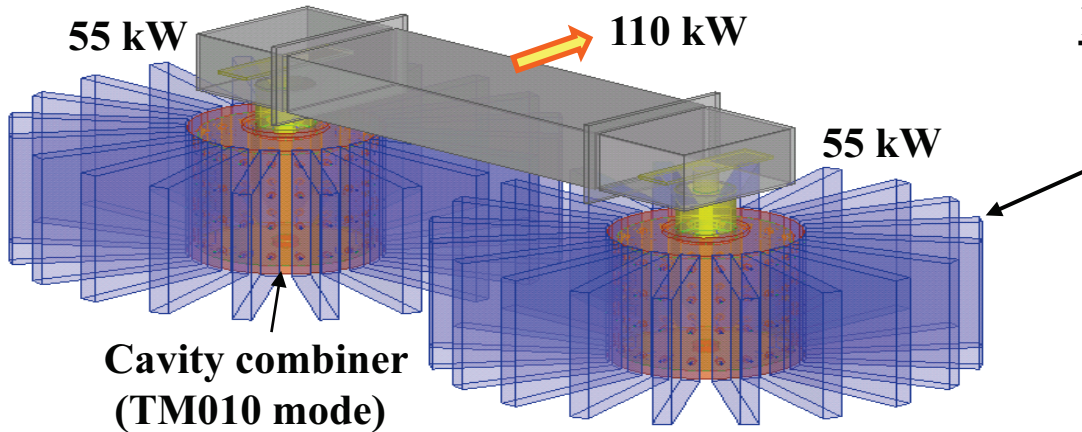

110 kW SSPA @ 509 MHz :

Combination of two 55 kW cavities  
20 «wings» are plugged on each cavity  
Each wing includes 4 modules of 600 W :

- 1 pre-amp
- 4 LDMOS
- 4 circulators

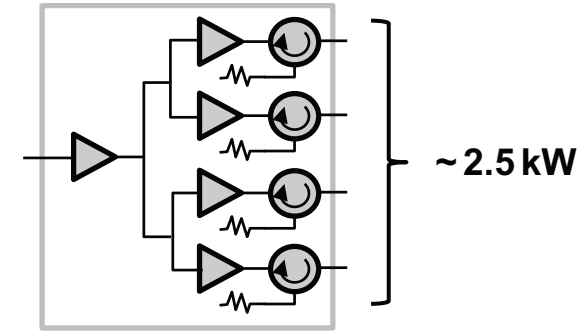

Prototype (single wing)  
was tested up to 1.7 kW

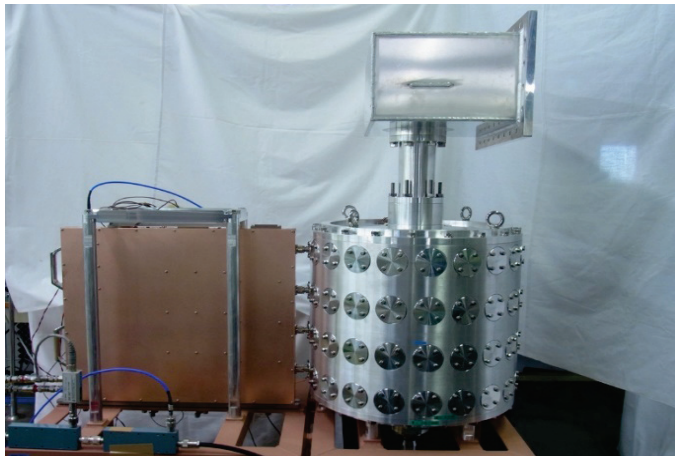

Coupling loops, integral to the cavity and adjustable in angle to limit the coupling dispersion

*Many other facilities are about to use 500 MHz SSPA, like CLS, DIAMOND, DELTA, ALBA, ELETTRA, SIRIUS and R&Ds in this domain are ongoing at other places, like ILSF (Iran), NSRRC (Taiwan), ...*

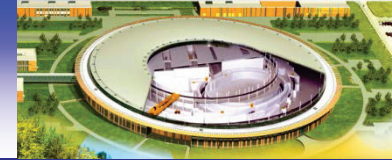

**Bruker, now SigmaPhi Electronics (SPE), has pioneered the extension of SSPA's to the L-Band in supplying 10 LDMOS-based SSPA's of 10 kW @ 1.3 GHz for ELBE in HZDR, where they perform very well since beginning of 2012**  
Efficiency ~ 47%

**Upgraded version of 16 kW, using new generation LDMOS, later supplied for the BerlinPro ERL (HZB); presently used in the HoBiCaT test bench**

**SPE is now producing 1.3 GHz SSPA, from 5 to 15 kW for TARLA, MESA and Cornell with RF modules of 500 W**

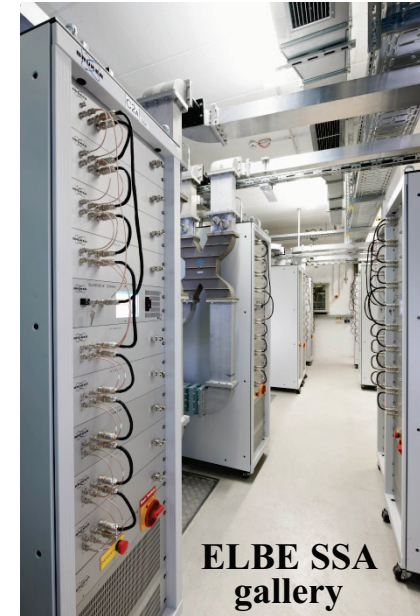
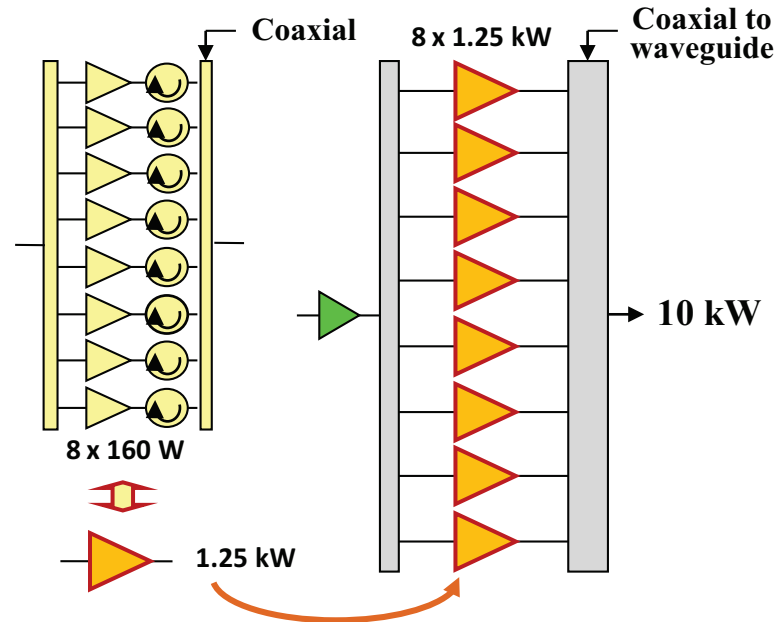

- Other 1.3 GHz SSPA applications**
- 284 SSA of 3.8 kW are under production for LCLS II in SLAC
  - 1 of 20 kW, built by BBEF, is used at the Beijing university
  - 1 of 20 kW, based on GaN, is developed by SOLEIL & SPE (LUCRECE)
- Above 1.3 GHz the LDMOS is supplanted by the GaN

**More generally, for UHF SSPA (L-band or 350-500 MHz), using a circulator per transistor is the key to success and that allows using any type of non-isolated combiners, coaxial, coax-to-waveguide or cavity. Large choice of commercial compact circulators in this frequency range and recent works, made by VALVO & SOLEIL, have led to the availability of such circulators down to 175 MHz.**



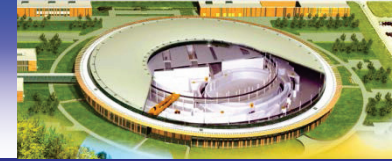

At GANIL, in SPIRAL2 sc LINAC, 4 types of 88 MHz SSPA :  
7 of 2.5 kW, 2 of 5 kW, 6 of 10 kW and 14 of 19 kW,  
supplied by BRUKER, now SigmaPhi Electronics (SPE)

They all combine 2.5 kW base units, which themselves are a combination of 4 LDMOS of 900 W with 3dB hybrid

At such a low frequency, it is hard building compact circulators, which could be integrated into the RF modules  
→ Use of a single power circulator at the amplifier output

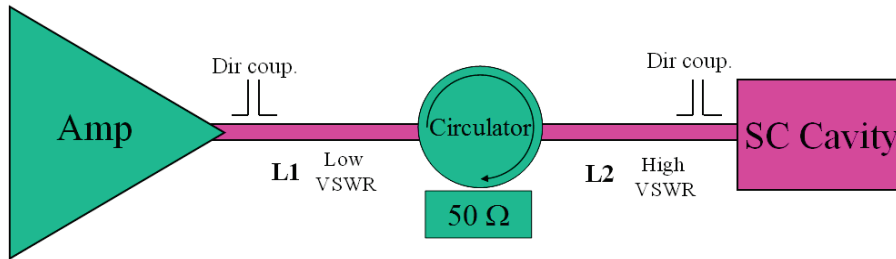

Isolation & impedance of the power circulator depends on the cavity operating conditions, with variable VSWR in L2  
→ Residual VSWR, induced through L1 on the SSPA is high enough to affect its performance

Indeed that required oversizing the SSPA & using phase shifters each side of the circulator to achieve the nominal power under any operating conditions

2.5 kW amplifier

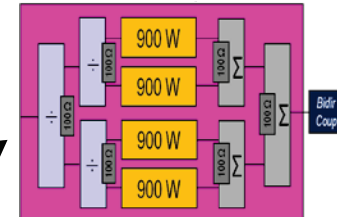

5 kW amplifier

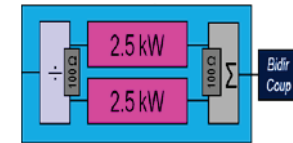

10 kW amplifier

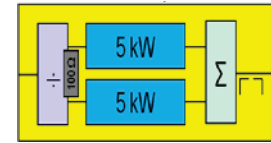

19 kW amplifier

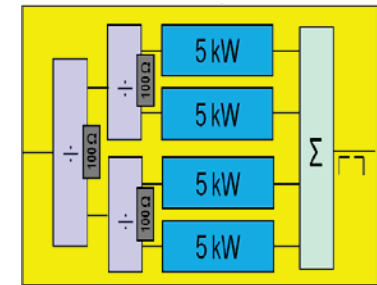

All amplifiers have passed the SAT and are being commissioned in SPIRAL2

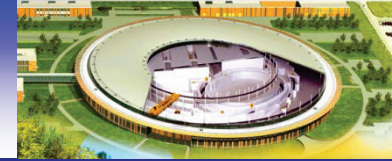

SSPA's of 60 kW @ 100 MHz from Rhode & Schwarz

1.5 GeV ring : 2 cavities, each powered with a 60 kW SSPA

3 GeV ring : 6 cavities, each powered with a 60 kW SSPA

Single high power circulator at the amplifier output

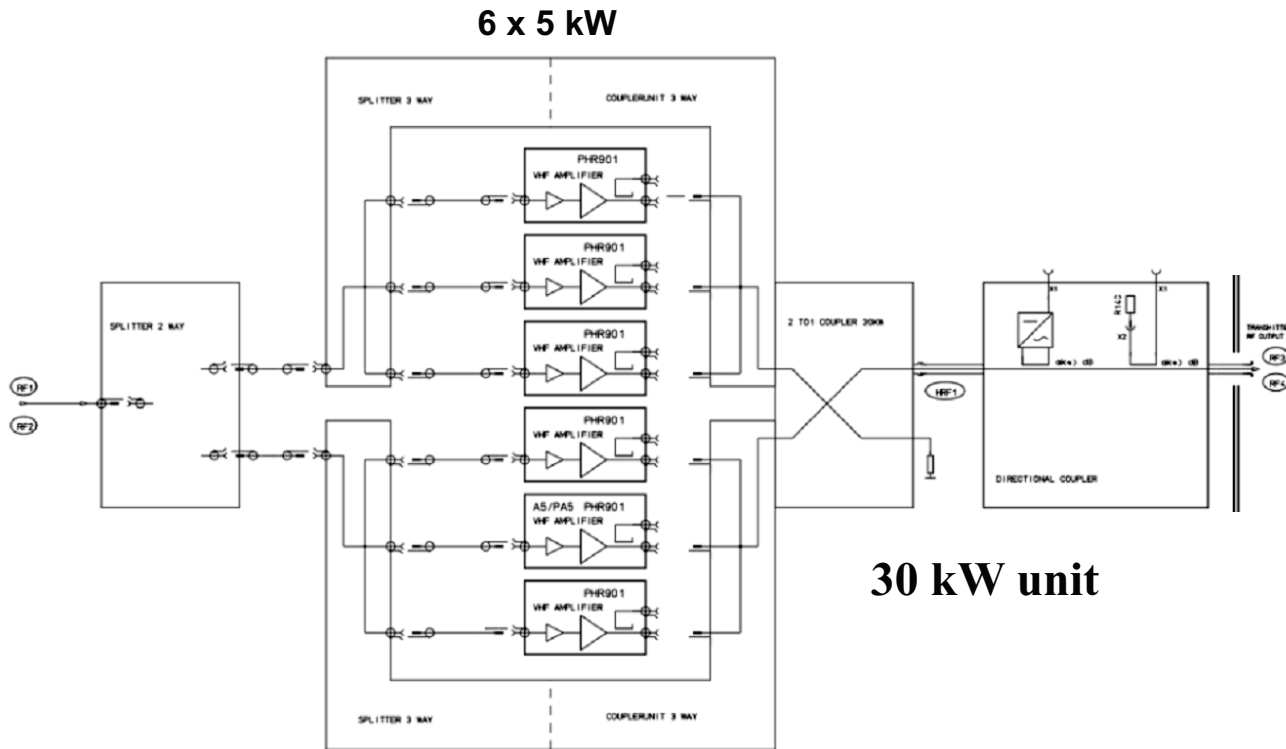

60 kW SSPA = 2 units of 30 kW  
combined with a 3 dB hybrid  
(efficiency ~ 66 %)

*Phase 2* : in the 3 GeV ring, 120 kW / cav from two 60 kW SSPA's, combined with 3 dB hybrid

*SOLARIS*, which is a replica of the MAX IV 1.5 GeV ring, is using the same 60 kW SSPA's



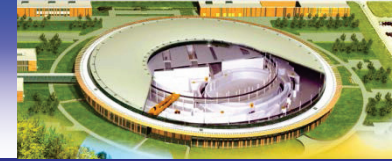

CERN has planned to replace its SPS 200 MHz tetrode transmitters by 2 SSPA of 2 MW peak (50% duty cycle)  
The world's largest SSPA's !

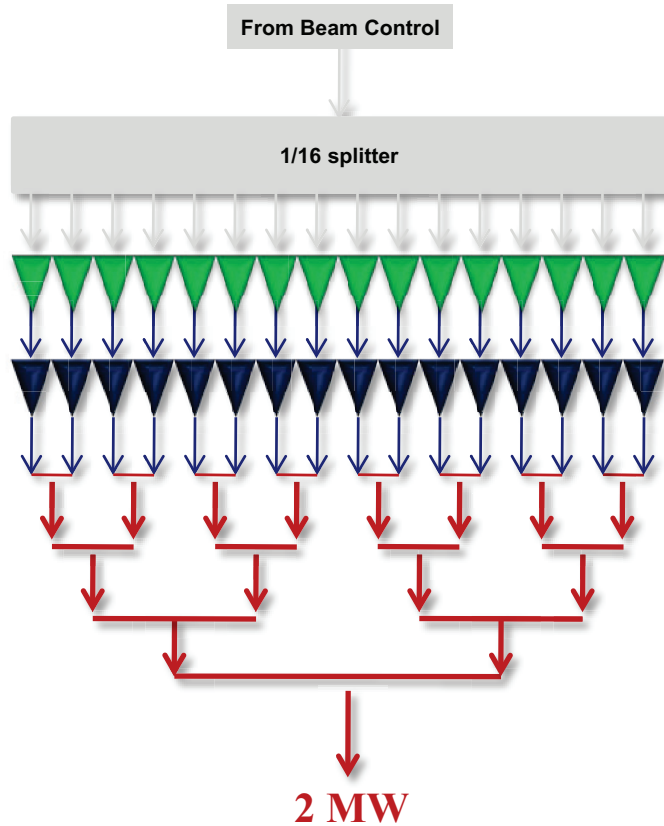

↑  
16 x 1.25 kW preamplifiers

16 x 140 kW amplifiers

4 stages of 3 dB hybrid coaxial combiners (as already existing)

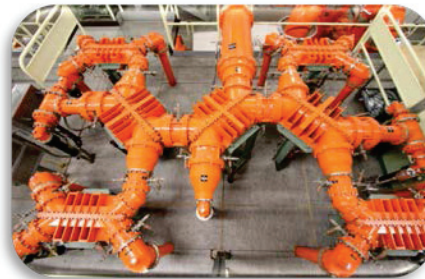

140 kW SSPA from THALES

- 2 kW RF modules
- 2 transistors / module
- 1 : 80 cavity combiner

A first demonstrator was recently tested ; a 2<sup>nd</sup> one, aimed at a long test run is under fabrication

- SOLEIL has built RF modules of 800 W at 176 MHz and 200 MHz with integrated circulators
- A 40 kW 204 MHz SSPA combining such modules is used in the SR of the Hefei light source in China
- A prototype of 160 kW 176 MHz SSPA is being produced by IBA for MYRRHA (research reactor in Belgium)
- For IFMIF, R&Ds with 175 MHz SSPA are ongoing in the frame of the LIPAc demonstrator

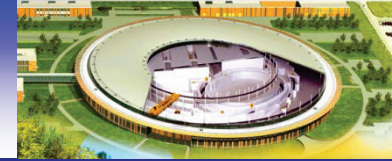

- ❑ **SOLEIL has run for ~ 11 years with 352 MHz SSPA's (35 kW in the BO, 4 x 180 kW in the SR); they have shown excellent operational availability, flexibility and MTBF. This experience has demonstrated that the SSPA can advantageously replace the vacuum tube in such CW application, thanks to its inherent modularity/redundancy, the absence of HV and its very low phase noise.**
- ❑ **R&D carried out at SOLEIL allowed improving the original design in compactness, reliability and efficiency along with the extension to other frequencies ; overall (plug to RF) efficiency ~ 65% are achieved at 352 MHz or lower frequencies, ~ 56% at 500 MHz and ~ 50% at 1.3 GHz.**
- ❑ **Following the success of the SOLEIL SSPA, several accelerator facilities expressed their intention of adopting this technology, which led SOLEIL to share its experience in this domain through scientific collaborations & technology transfers to the industry (ESRF, LNLS, ThomX, SESAME, LUCRECE, ...). Since 2014, SigmaPhi Electronics (SPE) is the unique SOLEIL licensee.**
- ❑ **SSPA technology has now reached maturity ; in addition to SOLEIL, SSPA's have run for more than 5 years in ESRF (352 MHz), LNLS (476 MHz), ELBE (1.3 GHz) and the operational experience feedbacks are excellent.**
- ❑ **It is being adopted by many other accelerator facilities and taken up by the industry for applications ranging from the FM to L band with power from a few 10 to few 100 kW.**
  - **In the upper frequency range, the key to success is the use of one circulator per transistor.**
  - **SOLEIL & Valvo have developed commercial compact circulators at frequency down to 175 MHz.**
  - **At lower frequency, the conventional Radio FM technique is applied, completed with a single power circulator at the SSPA output; this configuration remains very sensitive to residual VSWR.**
- ❑ **At frequencies above 1.3 GHz the GaN is supplanting the LDMOS transistor.**
- ❑ **R&D's are carried out with cavity combiners, which could be an alternative to coaxial combiners.**



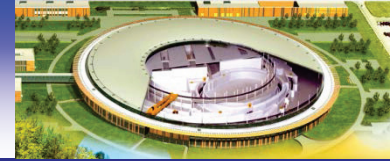

W. ANDERS (HZB)  
H. BÜTTIG (HZDR)  
D. HORAN (APS)  
M. GASPARI (PSI)  
T. INAGAKI (SPRING8)  
R.H. FARIAS (LNLS)  
M. LECHARTIER (GANIL)

J. JACOB, M. LANGLOIS, J.M. MERCIER (ESRF)  
L. MALMGREN (MAX IX)  
E. MONTESINOS (CERN)  
A.D. YEREMIAN (SLAC-LCLS II)  
N. PUPETER (CRYOELECTRA)  
C. SCHAN, D. LEOPOLDES (SigmaPhi Electronics)  
W. MATZIOL (VALVO Bauelemente)

## SOLEIL RF and LINAC group

R. CUOQ  
J.P. BAETE  
H. DIAS  
M. DIOP  
J. LABELLE  
R. LOPES  
M. LOUVET

P. MARCHAND  
C. MONNOT  
S. PETIT  
J.P. POLLINA  
F. RIBEIRO  
J. SALVIA  
R. SREEDHARAN

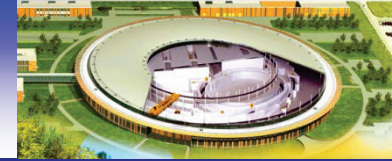

**Ti RUAN (1936 - 2014)**

He was **THE** pioneer in the domain of RF SSPA  
We are grateful for everything he brought to us