

OVERVIEW OF DRIVER TECHNOLOGIES FOR NANOSECOND TEM KICKERS*

A. Krasnykh, SLAC, Menlo Park, CA 94025, USA

Abstract

Overview of modern methods, circuits, and practical realizations for multi MW peak power pulsers are discussed. All used pulser components are manufactured by the US national industry and they are available for design and pulser fabrication. Two concepts will be discussed: (1) an approach is based on assistance of a nonlinear transmission line (NTL) with ferromagnetic media and (2) an approach is based on assistance of special diodes which are working in a specific mode of operation. In both approaches the nonlinear characteristic of switching media (ferromagnetic and solid state plasma) are employed in final stage of the pulser to form the multi MW level nanosecond pulses.

INTRODUCTION

Many accelerator projects employ a particle orbit control system for a bunch injection/extraction, for a “cleaning” of dark currents, for a distribution of bunch trains to the user beamlines or targets. The control system includes a pulser (or a driver) with an external trigger, a feeder, and an electrodynamic structure where the particle orbit control takes place. This overview will consider a conventional example i.e. with a 50 Ohm of the output driver and the feeder impedance accordingly and a multi MW peak output power. We also limit ourselves with a pulse width less than 50 nsec i.e. a case that a direct employment either fast thyratrons or solid state switches is challenge. For sure there are different engineering approaches to achieve above course spec: for instance, directly design a triggered spark gap etc. However sometime designers are looking for a cost effective way to solve a problem. Here author would like to share his experience with nanosecond driver technologies.

NTL WITH FERROMAGNETIC MEDIA

It is known that industrial powerful switches (such as gas filling tubes and IGBTs) possess the following feature. The current rise time through the switch is longer vs. higher switching current amplitude. It is not possible to get the rise time shorter than 40-50 nsec for multi MW peak at 50 Ohm resistive load via available components from the industry. Author contacted with the e2v thyatron experts to figure out whether or not the fast gas filing devices similar to the Russian pseudo spark switches [1]. It has been realized that there is not similar devices. Analysis of fastest thyatron specifications showed that the HY3189 thyatron available from industry and it would be a good candidate for a 10^{11} A/sec anode current rise rate. However this current rise rate was

confirmed neither in a ground cathode nor in ground grid mode of operation. Analysis of the Behlke high speed high voltage solid state switches [2] shows also a fact that the current rise rate is reduced vs. switching current amplitude.

It is known that the NTL behaves in an opposite way: a current rise rate is an inversely proportional of the acting current amplitude. The NTL can assist the industry available switches to get a high di/dt on a 50 Ohm load. Theory and engineering issues for a NTL design was developed in 60th [3, 4]. Below major features of this issues will be stressed. As follows from theory and experiments a structure of the initial wave (that propagates through the NTL) contains a regular and a shock electromagnetic part. The regular electromagnetic wave is a wave the shape/profile of which practically does not change while the wave propagates through a transmission line. The shock electromagnetic is a wave the shape/profile of which depends on levels of the current in the transmission line. A group velocity of the regular electromagnetic wave is $v_0 = \frac{c}{\sqrt{\epsilon_{eff}}}$, where c is speed of light and ϵ_{eff} is the effective dielectric constant. Spin reversal processes of the ferromagnetic media take place at the front of the wave only. A group velocity of the shock electromagnetic wave is $v_{sh} = \frac{c}{\sqrt{\epsilon_{eff}\mu_{sh}}} = \frac{v_0}{\sqrt{\mu_{sh}}}$, where μ_{sh} is the effective permeability of ferromagnetic media. A shock wave propagates in $\sqrt{\mu_{sh}}$ times slowly vs. the regular wave. The impedance on the front shock wave is higher in $\sqrt{\mu_{sh}}$ times vs. the impedance of the line where spin reversal processes are completed. The front of shock wave is in inverse variation vs. a magnetic field and a current accordingly. A difference in the velocities and impedances allows compressing of the electromagnetic power in the time while the wave propagates through the NTL. The compressing allows using the “slow” initial switch, i.e. assist a primary switch to get of a higher di/dt rate.

A simplified circuit topology shown in Figure 1 [5] was used to inject the nanosecond beam from linac into a circular orbit with a 35 cm equilibria radius.

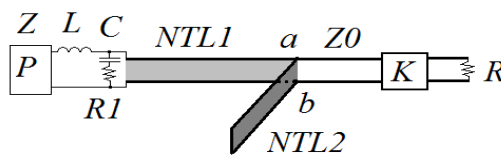

Figure 1: Driver with two NTLs where one NTL is shorted. Here P is initial pulser with Z output impedance, Z0 is a coax transmission line, K is TEM kicker, R is a matching resistive load.

*Work supported by US Department of Energy contract DE-AC02-76SF00515

A pulse generator P with the impedance Z forms an initial power step with a “slow” rise time and a “long” tail. This front propagates in the NTL1 and a shock wave is formed. A reflections from a slowly moving shock wave front are effectively dumped in the LCR1 components if $L/Z=R_1 \cdot C$. The wave is split on the a-b node. The wave in NTL2 reaches a shorted end and bounced to the a-b node. At this moment cores in both lines are saturated and the bounced wave starts to discharge all lines. The saturated impedance of the NTL2 line is equal to a parallel connection of the saturated NTL1 and Z0. There are no re-reflections between the a-b node and shorted end in the NTL2. The bounced wave in NTL2 will be split at the a-b node and will discharge the NTL1 and will form the tailing edge in the Z0 line. The shorted end mode on the NTL2 increases the amplitude of the reflection wave. A tailing edge of the reflected shock wave in NTL2 becomes shorter against the leading edge. The kicker driver can form 35 kV peak practically rectangular nanosecond pulses on the resistive loads.

A high power short nanosecond pulses was realized in the circuit layout that is shown in Figure 2.

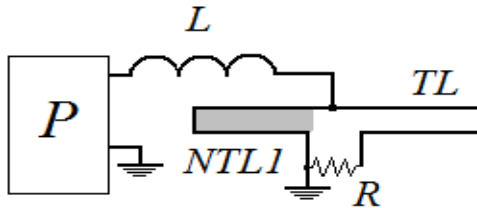

Figure 2: Driver with NTL and TL connected in the Blumlein manner [6].

A stored energy in P is discharged through the switch and L in a resonance manner. A shock wave is formed in NTL1. At a moment when the energy is delivered in NTL1 and TL, the shock wave reaches the shored end of the NTL1. Ferromagnetic cores in the NTL1 are saturated and a discharge process in both lines is started. A discharge circuit topology at this moment represents a classical Blumlein case. It should be noted a fact of a pre-pulse presence on output resistive load R (see Figure 3). This pre-pulse is formed during charging of NTL1 and TL. An output waveform from a driver topology shown in Figure 2 is illustrated in Figure 3.

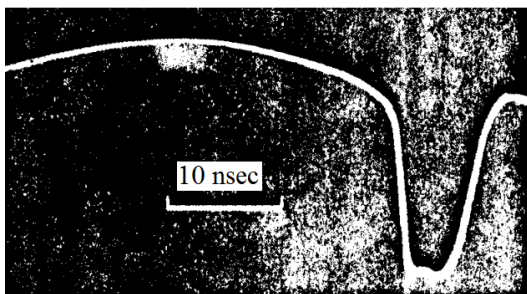

Figure 3: A 50 kV peak at 50 Ohm, 6 nsec FWHM pulse with a pre-pulse [7].

A circuit topology shown in Figure 4 was experimentally evaluated too.

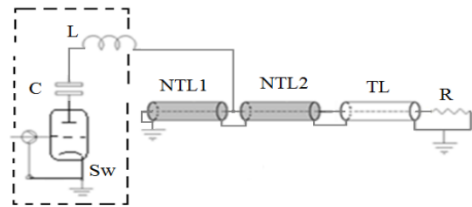

Figure 4: Driver with two series connected NTLs.

A basic idea was to evaluate whether or not this simple circuit is able to generate a 10 nsec pulse on a 50 Ohm load. A 15 nsec pulse at 50 Ohm load is shown in Figure 5.

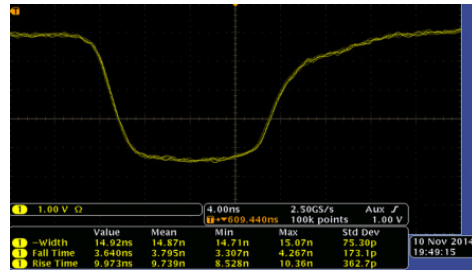

Figure 5: Waveform of a 15 nsec pulse.

Amplitude pulse is only 7 kV when the anode voltage at the switch is 20 kV. A low energy transferring efficiency from primary storage to the NTL1 and NTL2 is mainly limited by the switching losses in the HY3189 thyatron. The efficiency could be increased if (for example, magnetic switching cells are employed). However the circuit gets complicity.

A circuit for a generation of the pulse width less than 10 nsec is shown in Figure 6.

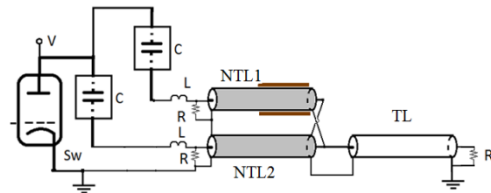

Figure 6: Driver with two NTLs connected inversely.

In this case there is a small delay in the propagation delay in NTLs. This delay was controlled by the reset core current.

DRIVER LAYOUTS BASED ON DSRD

The DSRD is a special switching two electrode device [8]. A nanosecond turn OFF mode allows assisting three electrode “slow” switches. Theory and engineering issues for a DSRD design was developed in 80th [9]. A technology of the DSRD fabrication was developed in the former USSR. A DSRD user community is not large and that is why there is not a western supplier of similar devices in the past. This statement is not accurate for a present-day, because the DSRD production capability has been transferred the USA in a period from 2006 to 2013 under the SBIR DoE Phase I and II grant.

DSRD is a two-terminal dynamic OFF switch. The DSRD impedance is controlled by the following condition

$$\int_0^{t1} I_{FWD}(t)dt = \int_{t1}^{t2} I_{RE}(t)dt$$

where I_{FWD} and $0-t_1$ are a current and a time interval in a forward diode direction. I_{RE} and $t_2 - t_1$ are a current and an interval in a reverse direction. Simplified circuit layouts for the DSRD mode operation is shown in Figure 7.

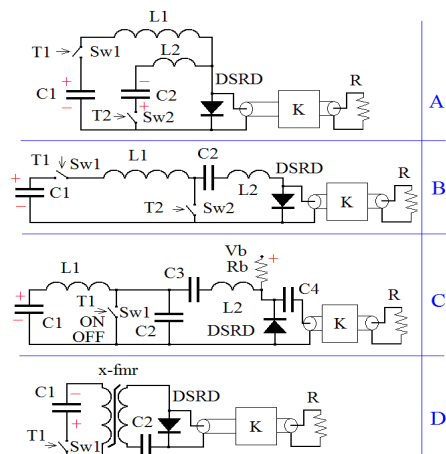

Figure 7: Simplified circuit layouts with the DSRD assistance.

The “A” and “B” drivers required two ON-type switches (Sw1 and Sw2) that are synchronized independently via T1 and T2. Amplitudes I_{FWD} and I_{RE} depend upon charging voltages, and parameters of L1, C1, L2, and C2. The “C” and “D” topologies employ only one primary switch (Sw1). However the “C” driver uses the ON/OFF switch. A fast MOSFET array is typically used to pump the DSRD stack in this case. The “C” topology is used to generate a waveform with a 0.7/0.8 nsec of rise/fall times (see Figure 8). In this case a single DSRD tiny crystal was used.

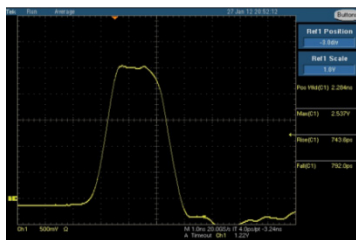

Figure 8 Waveform via a single DSRD crystal.

Figure 9 shows a 9 nsec FWHM, 5 kV peak pulse (fall/rise times are 1.6/5.2 nsec accordingly). In this case the driver was built according to the “D” circuit layout. 16 ea. diodes were assembled in this DSRD package. A repletion rate in this circuit was limited by an allowed temperature rise in the magnetic cores of the saturated transformers.

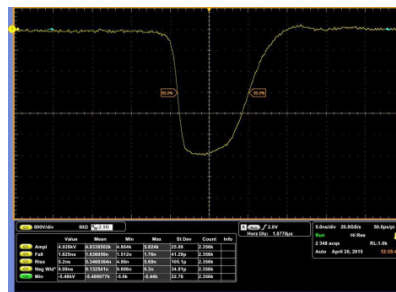

Figure 9: Waveform via a 16 ea. of single DSRDs.

The “B” driver was used for a generation of a 3 nsec, 4.4 kV pulse with a 3 MHz repetition rate [10]. A detail analysis of how the “B” driver works the reader can find in [10] too.

CONCLUSION

A brief overview of multi MW nanosecond range driver technologies is discussed. All circuit components are available from industry for obtaining nanosecond, kilovolt pulses. DSRD-based approach are preferable because, (1) only a low voltage power supply is required to produce a multi-MW nanosecond pulses, and, (2) since the DSRD switch is normally closed, voltage stress is limited by a nanosecond period, hence the susceptibility to hostile environment conditions such as ionizing radiation, mismatch, strong electromagnetic noise levels, etc. is expected to be minimal.

REFERENCES

- [1] V.D. Bochkov, *et al.*, “SN-series Pseudospark Switches, ACTA PHYSICA POLONICA A, v 115, p. 980 (2009).
- [2] <http://www.behlke.com>
- [3] I.G. Kataev, “Electromagnetic Shock Waves”, 1963.
- [4] A.V Gaponov, *et al.*, “Electromagnetic Shock Waves”, Izvestia Vuz., Radiofizika, vol. 10, p. 1376 (1967).
- [5] G.V. Dolbilov, *et al.*, “Injection System”, II Symposium on Collective Methods of Acceleration, Dubna (1976).
- [6] G. Dolbilov, A. Krasnykh and V. Razuvakin, “An Employment of Magnetic Switching Cells and Nonlinear Lines in the Induction Linac Modulators”, Prib. Tech. Eksp., v. 4, p. 26 (1984).
- [7] A.N. Meshkov, *et al.* “Generators of Nanosecond Pulses Based on Magnetic Switching Cells”, Ibid. v.1 p. 24 (1990).
- [8] I.V. Grekhov *et al.*, ”High-power Sub nanosecond Switch”, Electronics Letters, v. 17, p. 422 (1981).
- [9] I.V. Grekhov and G.A. Mesyats, “Nanosecond semiconductor diodes for pulsed power switching”, Uspekhi Fizicheskikh Nauk v. 175, p. 735 (2005).
- [10] F. Arntz, A. Kardo-Sysoev, and A. Krasnykh, “SLIM, Short-pulse Technology for High Gradient Induction Accelerators”, SLAC-PUB-13477.