

DESIGN AND SIMULATIONS OF THE CAVITY BPM READOUT ELECTRONICS FOR THE ELI-NP GAMMA BEAM SYSTEM

M. Cargnelutti, B. Baričević, Instrumentation Technologies, Solkan, Slovenia
 A. Mostacci, Sapienza Università di Roma, Rome, Italy
 S. Pioli, A. Stella, A. Variola, M.Serio, INFN-LNF, Frascati, Italy

Abstract

The Extreme Light Infrastructure – Nuclear Physics (ELI-NP) facility will provide a high intensity laser and a very intense gamma beam which will be used in a broad range of experiments. The gamma beam is obtained through incoherent Compton back-scattering of a laser light off a high brightness electron beam provided by a 720MeV warm LINAC. Electrons are accelerated in trains with up to 32 bunches, each one separated by 16ns. In the laser-electron interaction region, every bunch needs to be monitored with a resolution below $1\mu\text{m}$ RMS.

To achieve this performance, a low-Q cavity beam position monitor will be used in combination with a dedicated data acquisition system able to perform bunch-by-bunch beam position measurements with sub- μm resolution. Using fast A/D converters and specific digital filtering, the readout system proposes an alternative measurement concept. The requirements of the system, its design and the results from the simulations will be presented.

INTRODUCTION

The relativistic electron beam required to generate the ELI-NP high-intensity gamma beam will be provided by a warm LINAC. The accelerator consists of an S-band photo-injector followed by C-band accelerating structures, combining a conservative injector design with compact accelerating structures [1]. At every injection up to 32 electron bunches are accelerated and delivered to two interaction points (IPs) with energies of 280MeV and 720MeV. The parameters describing the electron beam characteristics are listed in Table 1.

Table 1: ELI-NP LINAC Beam Parameters

Parameter	Value	Unit
Beam Energy	80-720	MeV
Bunch charge	25-400	pC
Bunch separation	16.1	ns
Bunches per pulse	≤ 32	units
Bunch energy spread	0.04-0.1	%
Focal spot size	> 10	μm
Pulse repetition rate	100	Hz

In order to align the beam at the IP, the position of the electrons in the range of $\pm 1\text{mm}$ has to be measured for each bunch with sub- μm resolution.

THE BPM16 CAVITY BPM

To achieve the required high-resolution position measurement, four low-Q cavity beam position monitors (BPMs) are used. The cavity pick-up is the BPM16 model which is also used in the SwissFEL facility [2], consisting of one reference cavity and two position cavities. Its main parameters are presented in Table 2.

Table 2: Parameters of the BPM16 Cavity

Parameter	Reference Cavity	Position Cavity
Material	Stainless Steel	Stainless Steel
Resonant mode	TM ₀₁₀	TM ₁₁₀
Resonant frequency	3.284GHz	3.284GHz
Loaded Q	40	40
Bandwidth	82.1MHz	82.1MHz
Signal sensitivity	135V/nC	7.07V/mm/nC
Inner aperture	16mm	16mm

The cavity perfectly fits in the ELI-NP accelerator layout since its aperture is the same and the low quality factor enables the independent measure of each bunch: the signal excited by one bunch will decay fast enough to not interfere with the signal coming from the next bunch (will reach 10% of its initial value in 8.92ns).

Figure 1 shows a simulation of the signal shapes expected from the pick-up when a bunch train passes through it, where the third bunch is missing on purpose. The amplitude is equalized for both cavities using some attenuators before inputting the signal into the electronics.

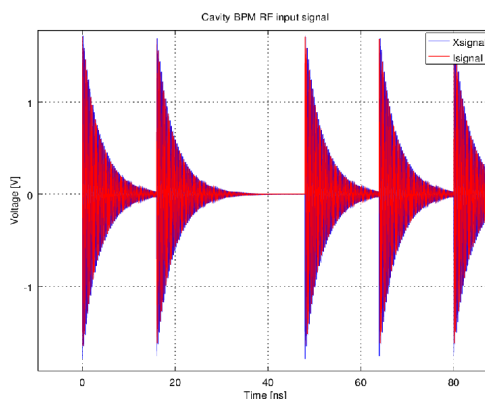

Figure 1: BPM16 expected output signal.

DESIGN OF THE ELECTRONICS

Different processing techniques have been proposed to handle the cavity BPM signals [2-6]: the approach depends on the cavity parameters and machine operation mode. The RF front-end typically includes filters to remove the unwanted frequency components from the signal, variable attenuators to optimize the signal level depending on the beam conditions (e.g. charge, position) and mixers to down-convert the cavity signal to a lower intermediate frequency (IF) which is easier to digitize.

RF Front-end and A/D Conversion

The proposed solution uses the same approach: a simplified block diagram of the RF front-end for only one input channel is presented in Figure 2. A reference signal at the bunch repetition frequency (62.02MHz) is provided by the timing system to two Phase Locked Loops (PLLs) which generate the ADC sampling frequency and the down-conversion mixer components. The cavity input signal is adjusted with the attenuators and down-converted to 375MHz. Later on a filter with 116MHz bandwidth limits the signal harmonic content to the second Nyquist zone preparing it for the A/D conversion, done with 500MSps – 14bit ADC converters.

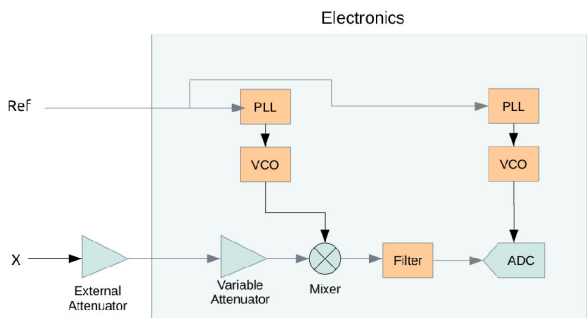

Figure 2: Block diagram of the electronics RF front-end.

In the case of bunches separated by only 16.1ns, this conversion provides 8 ADC samples per bunch from which the position is later extracted.

Bunch Decoupling and Deconvolution Filter

Once the signals are digitized, the samples belonging to different bunches have to be separated. This is done with a calibration procedure which associates 8 ADC samples to each bunch and assures that the center of mass of the bunches is centred in the vector of samples – see Figure 3.A where the red circles are the limits of each bunch.

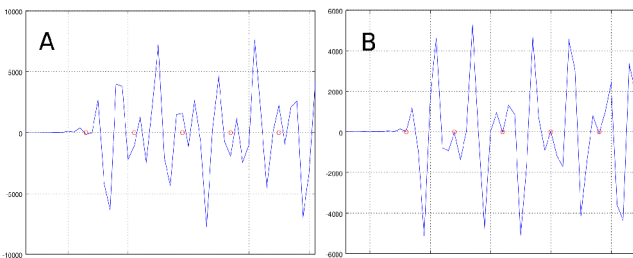

Figure 3: Digitized input signal after calibration (A) and deconvolution filter (B).

Later on a special deconvolution filter extracts from each bunch the expected signal response and compresses the signal towards the center in order not to have coupling between them. This is implemented with a FIR filter with 100 taps – see its output in Figure 3.B.

Position Calculation

Once the data of each bunch is separated, it is possible to calculate the amplitude (V_x, V_y, V_r) associated to each cavity signal through a sum-of-squares formula and to calculate the absolute position value with the equations:

$$X = K_x \frac{V_x}{V_r} \quad Y = K_y \frac{V_y}{V_r}$$

where K_x, K_y are calibration constants which depend on the sensitivity of the cavities and on specific value of the variable attenuators. To resolve the sign of the position it is necessary to study the phase relation between the position and the reference cavity, and this is done in parallel through an I/Q demodulation.

PERFORMANCE SIMULATIONS

According with the expected input signals, the structure of the RF front-end and the discussed processing algorithms it is possible to simulate the performance of the system in different conditions like single-bunch and bunch-train operating modes.

Simulations in Single-bunch Mode

As a first measurement, a single-bunch with 900µm offset from the beam pipe center is considered. Several measurements are simulated and the position resolution is estimated as their standard deviation. Figure 4 presents how the position resolution depends on the bunch charge and the variable attenuator setting: sub-µm resolution can be achieved for every charge level.

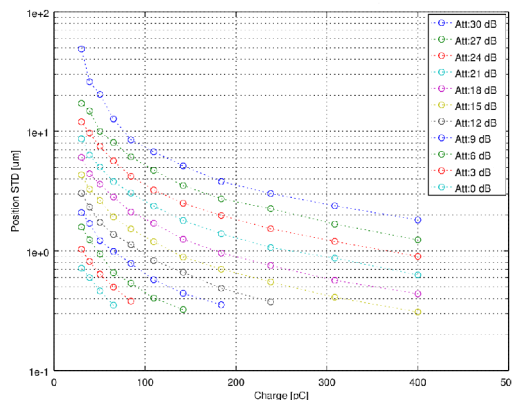

Figure 4: Position resolution in single-bunch mode.

Depending on the beam charge and position also the position measurement range changes. This dependence is shown in Figure 5, again parametrized depending on the variable attenuator setting.

Finally if the beam is moved in a certain position range, the position measurement resolution remains relatively stable with the exception of the cavity center where the

dipole signal produced by the position cavity is weaker and dominated by the noise.

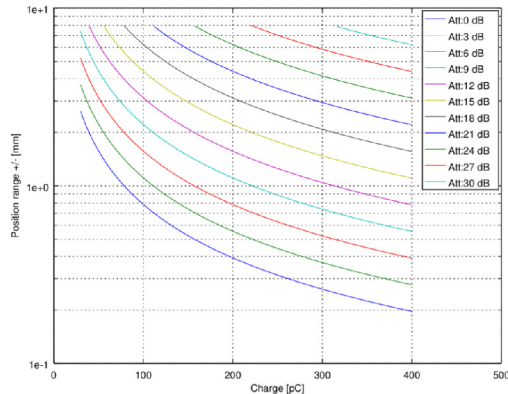

Figure 5: Position measurement range depending on bunch charge and attenuators setting.

Simulations in Bunch Train Mode

The simulations in bunch train mode are carried out with the purpose to evaluate the capability of the system to measure each bunch position in the train, without coupling effects. For this reason a train of 32 bunches is simulated with 400pC bunch charge and an attenuation setting of 15dB. The position of each bunch along the train is modulated as a cosine signal in the range of $\pm 100\mu\text{m}$, see the blue circles in Figure 6.A. The result of the position calculation is represented with the green crosses in the same picture.

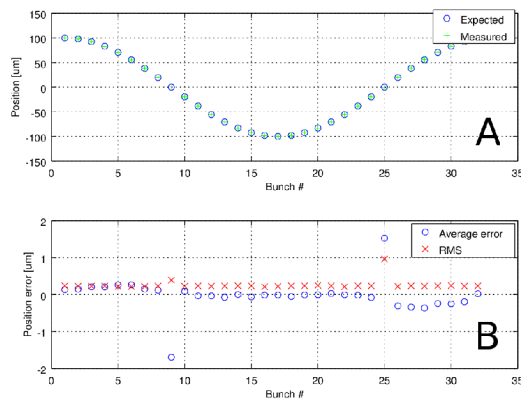

Figure 6: Position measurements in bunch train mode.

The red crosses in Figure 6.B represent the resolution of each bunch measurement, in line with what presented in Figure 4 ($\sim 300\mu\text{m}$). In the same figure the blue circles show the measurement accuracy, which proves to be lower only when the bunches cross the pipe center.

FIRST PROTOTYPE RESULTS

The development of the electronics for the ELI-NP project is carried on by Instrumentation Technologies and is organized in two phases. Purpose of the first phase is to prove the design and performance of the RF front-end the fast A/D conversion, while the second phase proves the digital signal processing and the final performance. The first development phase resulted in a first prototype

consisting of evaluation boards interconnected together: FPGA and ADC boards, two PLL boards and a prototype of the RF front-end – see Figure 7.

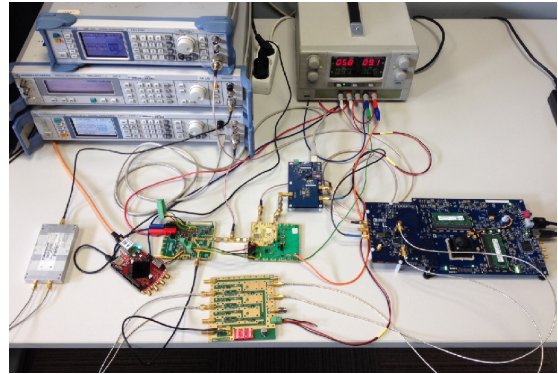

Figure 7: First development phase prototype.

Part of the tests carried out with the first prototype were functional, with the purpose to demonstrate that all the blocks can work together. Performance measurements were done on the acquired ADC signals to evaluate the noise contribution of the RF front-end, and proved to be in line with the expected results.

CONCLUSIONS

The electronics for the ELI-NP electron LINAC cavity BPM system are currently being developed. The system is required to measure the position of each electron bunch independently and with sub- μm resolution in the range of $\pm 1\text{mm}$ from the pipe center.

The proposed design consists of an RF front-end which down-converts the cavity input signal preserving each individual bunch contribution, fast A/D converters to extract enough information from the signal and custom FPGA algorithms to decouple the acquired bunch samples and compute the beam position.

The measurements done with the prototype developed during the first project phase confirmed the feasibility of the development and the performance of the RF front-end.

REFERENCES

- [1] L. Serafini et al., “Technical Design Report - EuroGammaS proposal for the ELI-NP Gamma beam System”, July 14th, 2014.
- [2] B. Keil et al., “Design of the SwissFEL BPM System”, IBIC2013, Oxford, UK.
- [3] D. Lipka, “Cavity BPM Designs, Related Electronics and Measured Performances”, DIPAC09, Basel, CH
- [4] A. Young et al., “Performance Measurements of the New X-Band Cavity BPM Receiver”, IBIC2013, Oxford, UK.
- [5] H. Maesaka et al., “Performance of the RF Cavity BPM at XFEL/SPRING-8 'SACLA'”, FEL2011, Shanghai, CN.
- [6] Y. I. Kim et al., “Cavity beam position monitor system for the Accelerator Test Facility 2 ”, Phys. Rev. ST Accel. Beams 15, 042801 (2012).