

BEAM DIAGNOSTICS OVERVIEW FOR COLLECTOR RING AT FAIR*

Yu. A. Rogovsky^{†1,2}, E.A. Bekhtenev¹, M.I. Bryzgunov, O.I. Meshkov¹, D.B. Shwartz^{1,2},
 Budker Institute of Nuclear Physics, SB RAS, Novosibirsk, Russia
¹Novosibirsk State University, Novosibirsk, Russia
²FSBI "SSC RF ITEP" of NRC "Kurchatov Institute", Moscow, Russia
 O. Chorniy, GSI Helmholtzzentrum für Schwerionenforschung, Darmstadt, Germany

Abstract

The Collector Ring (CR) [1] is an essential ring of the new international accelerator Facility of Antiproton and Ion Research (FAIR) [2] at Darmstadt, Germany. It will operate with antiproton energy of 3 GeV and has a complex operation scheme and several types of operational cycles. In this paper, we present an overview of all diagnostic systems, which are planned for commissioning and operations. Challenges and solutions for various diagnostic installations will be given.

INTRODUCTION

The main emphasis of the CR is laid on the effective stochastic precooling of intense Rare Isotope Beams (RIBs), secondary stable beams and/or antiproton as well. Special task – mass and half-life measurements of very short-lived nuclides (down to few tens μ s) will be performed in the CR operated in isochronous mode [3].

Table 1: Main Parameters of the CR

Parameter	Value		
Circumference	221.45 m		
B ρ	13 Tm		
Mode	p-bar	RIB	Isochronous
Max. intensity	10 ⁸	10 ⁹	1-10 ⁸
Particl. charge	1	40-100	40-100
Repetit. rate	1	1	—
Kinetic energy	3 GeV	740 MeV/u	400-790 MeV/u
Lorentz γ	4.20	1.79	1.43 – 1.84
Transition γ_{tr}	4.83	2.727	1.43 – 1.84
Slip factor $ \eta $	0.014	0.1776	0
Acceptance	240	200	100
RF freq., MHz	1.315	1.124	0.968-1.137
RF harmonic	1	1	—
Betatron tunes	4.39/3.42	3.40/3.44	2.21/4.27
Bunch length	50 ns	50 ns	—

There are several types of operational cycles with beams in CR starting from injection and finishing with extraction, and beam parameters change significantly during the cycles. The momentum spread is largest at injection, when very short bunches of several tens ns from the production targets (either RIBs or antiprotons) are injected. At this instant, the horizontal aperture of the ring is filled.

* The work is carried out with the financial support of FAIR-Russia Research Center

† rogovsky@inp.nsk.su

After a 1.5 ms bunch rotation and a 150 ms adiabatic debunching, the momentum spread is decreased, whereas this process leaves the transverse emittance unchanged in both directions. After these procedures the bunch fills all the perimeter of the CR. The reduced momentum spread is a necessary prerequisite for stochastic cooling. The cooling time for the antiprotons is 10 s and is estimated as 5 s after further CR upgrade. The cooling time for highly charged RIBs is much shorter (1.5 s). After the procedure of stochastic cooling, all phase subspaces are strongly reduced. The cooling is followed by the re-bunching procedure in 130 ms and further extraction of the beam.

Beam parameters changes significantly during the cycles as well as along the ring [4]. This demands an exceptional high dynamic range for the beam instrumentation and non-destructive methods are mandatory for high currents as well as for the low current secondary beams due to the low repetition rate. Precise measurements of all beam parameters and automatic steering with short response time are required due to the necessary exploitation of the full ring acceptances.

BEAM DIAGNOSTICS SUITE

The beam diagnostic systems are designed to provide a complete characterization of the beam properties including beam closed orbit, size, tune, circulating current, fill pattern, lifetime, chromaticity, beam loss pattern, beam density distribution, emittance, and bunch length. A large number of beam monitors and will be installed in the ring.

Table 2: List of Beam Diagnostics at CR

Beam Monitor	Amount
Position Pick-up	19
DC Current Transformer	1
Fast Current Transformer	1
Residual Gas Profile Monitor	2
Broadband Schottky Pick-up	1
Beam Stopper	2
Scintillating Screen	5
Beam Scrapper	20
Cryogenic Current Comparator	1
BTF Exciter	1

Electrostatic Pick-ups (18 combined and 1 vertical) measure the beam centre-of-charge transverse position in a non-interceptive way. In normal operation mode, the Pick-up signals are averaged for orbit corrections [5]. Alternatively a subset of the monitors can be read out turn-by-turn,

synchronized to the bunch passage for tune measurements, etc.

A Fast Current Transformer provides the longitudinal structure with turn-by-turn resolution during bunch rotation in longitudinal phase space. A DC Current provides the total number of ions circulating in the ring. Both Fast CT and DC Current Transformers will have calibration coils implemented. To determine the circulating current, one Cryogenic Current Comparator (CCC) will be installed with a detection limit of few nA, well below the threshold of regular transformers.

A combined Schottky Pick-up measure the relative momentum spread $\Delta p/p$, the non-integer part of the betatron tune Q , the tune spread and the transverse velocity spread. These monitors are of special interest as CR will have almost coasting beam during the cooling process.

An array of scintillating screens is deployed to provide transverse profiles at strategic locations throughout the ring.

A combined Residual Gas Monitors (RGM) measure transverse beam profile in a non-interceptive way, thus giving us an important tool for determination of the beam emittance and its evolution during the acceleration and cooling process.

Beam Position

The BPM system based on linear-cut type electrodes will measure the beam position as well as an approximate beam current. As far as possible, BPM sensors will be physically located near quadrupoles, since the goal of beam steering normally is to center the beam in the quadrupoles.

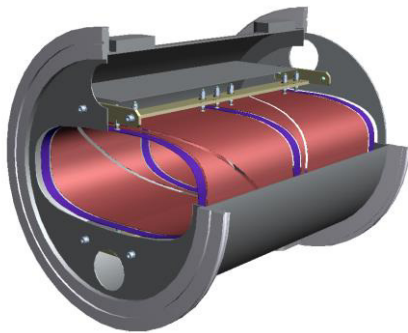

Figure 1: A large (400 mm) aperture, super-elliptical, split plate BPM design in dispersive section provides a larger linear response aperture.

The linear-cut electrodes geometry is designed to fit the beam without losses: in straight section beam has almost equal sizes less than 80 mm, but in arcs beam has horizontal size 360 mm, while vertical size less than 80 mm. Additional “groundings” electrodes introduced to vanish parasitic influence between pairs of electrodes. Polynomial correction removes geometric nonlinearities from the difference-over-sum algorithm, providing position error less than 100 μm over $\sim 90\%$ of the BPM aperture.

The CR has quite limited space for beam diagnostics installations. Despite this fact, the BPMs will be installed between the main magnetic elements but will be integrated with its vacuum chamber into vertical dipole corrector (see

left side in Figure 2) which can adopt quite huge aperture. There will be 4 “small” BPMs in the straight sections (shown on right side in Figure 2) and 6+7 “big” BPMs in arcs of the CR. Additional “big” BPM will be installed just after injection where TCR1 and CR vacuum chambers combines to measure the position during injection or during stable operations. One more “big” BPM will be installed just before extraction line where beam orbit will be shifted towards the extraction [6].

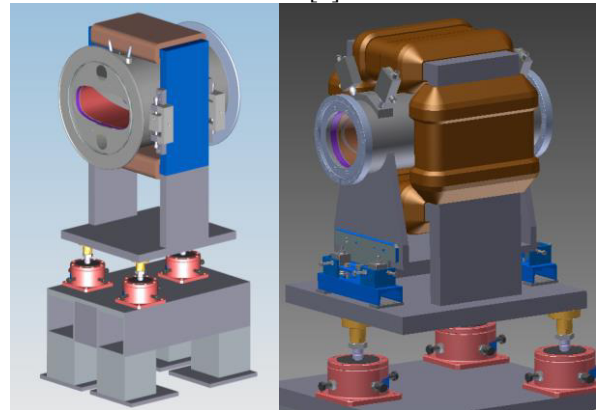

Figure 2: BPM installed in vertical (left) and combined (right) dipole corrector.

Beam Profile

An RGM principle of operation is based on measuring the profile of secondary ions appeared in the process of ionization of residual gas by the main beam. For the collection of secondary ions in the profile monitor a transverse electric field is applied, which sends positively charged ions to the detector. Uniformity of the electric field should be sufficient to provide the required spatial resolution of profile measurement. The position-sensitive optical particle detector measures density distribution of secondary particles, which is proportional to transverse beam profile in one direction.

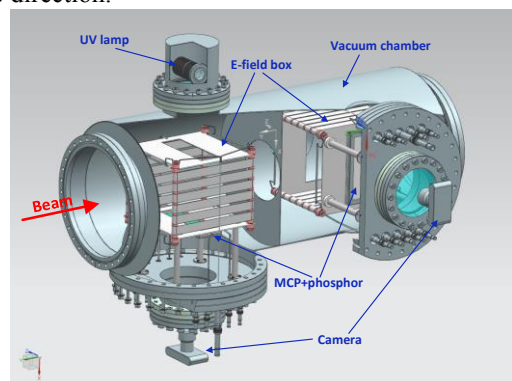

Figure 3: Combined RGM and its components.

This monitor is designed for high-current operation where conventional intercepting diagnostics will not withstand high-intensity ion beams.

The system in principle can operate with different detector where electrons, which appear at the exit of MCP, go directly to resistive plate, thus, locally charging it. Measuring the charge flows from both ends of the plate, you can determine where electronic avalanche hits the plate. The

advantage of this approach is a total elimination of the transformation of particle flux to light, which, due to the reflections can lead to spurious peaks in the measured profile.

For the same purpose of beam profile measurements, five scintillating screen monitors are installed in the injection/extraction area, downstream of the electrostatic injection septum and in arcs centres. One of the screens observes the beam directly after injection and after the first turn in the machine in principle.

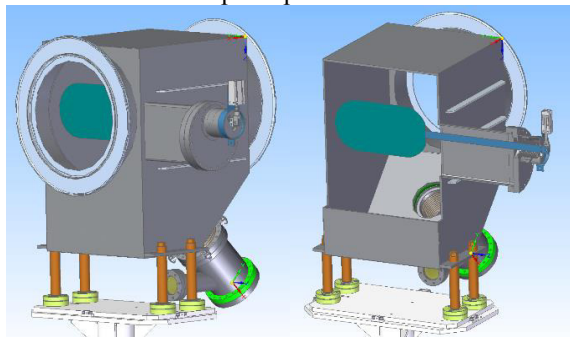

Figure 4: Scintillating screen and its cross section.

Beam Intensity

During the commissioning and tuning phase of the CR ring, insertable Faraday cups (or Beam Stoppers) will measure current, while isolating the downstream accelerator components from the beam.

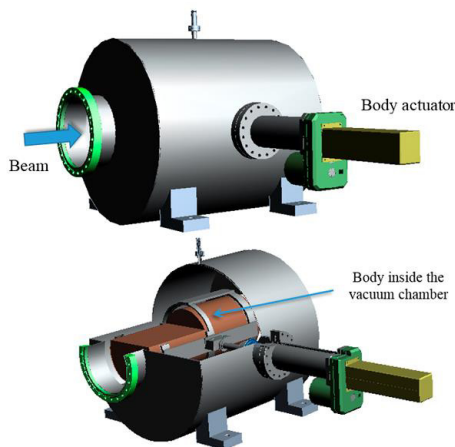

Figure 5: Faraday cup with longitudinally sectioned body.

The main requirements for this device in CR is to full stop of incoming ions and partial stop of antiprotons (with kinetic energy losses up to 10%). The body of FC will consist of two parts – relatively short part $\sim 1/3$ from Cu (for stopping ions and measuring intensity) and $\sim 2/3$ part from Pu (for stopping antiprotons). Preliminary simulations shows that ions are stopped at the first 2-3 cm of the stopper body ($Z=40$, $E=750$ MeV/nucleon), and 40 cm of Pb in length is excessive for reasonable design of the stopper.

Beam Tunes

Schottky Pick-up consists of four cylindrical stripline type electrodes connected to vacuum chamber and feed-through to provide signal for further processing. This as-

sembly is a part of beam line. These electrodes in combination with vacuum chamber are considered as transmission line. The pick-up geometry should be an object of optimization where two most important criteria are field homogeneity and matching of the signal path to 50 Ohm.

Beam Loss Detection

The beam loss monitoring (BLM) has the dual purpose of keeping the machine safe from beam - induced damage and avoiding excessive machine activation by providing critical input to the machine protection system. Thus, the system must be designed complete coverage of possible loss scenarios. In addition, as the BLM system will be a major tool for beam tune-up, it should also be designed in a way that enables it to pin-point the loss location as precisely as possible. The optimal location of detectors will be determined by simulations in nearest future.

Other Diagnostics

Five sets of scrapers with four blades in each planned, to provide several functions: 1) control the loss point for beam aborts or dumps, 2) limit the particles losses that create radiation on RF cavities with quite small cross section, and 3) for diagnostics and physics studies of the dynamic and momentum aperture of the ring.

Several other diagnostics systems are also in a mature stage but are not discussed here. These systems include CCC current measurement, BTF exciter, and 2-position scintillating screen, commercially available FCT and DCCT devices from Bergoz Instrumentation.

CONCLUSION

An overview of the proposed beam diagnostics concept for CR given in this paper. The results from ongoing research, developments and preliminary design work of BINP and GSI teams have been shown. The design level of subsystems is now mature and provides a firm basis to meet challenging requirements of diagnostics relating to the all requirements of CR.

REFERENCES

- [1] Yu. Rogovsky et al., "Storage ring CR of the FAIR facility, in Proc. RUPAC'14, Obninsk, Russia, Oct. 2014, paper FRCA01.
- [2] FAIR, <http://www.fair-center.eu>
- [3] A. Dolinskii et al., NIM A 574, 207-212 (2007).
- [4] D. Shwartz et al., "Beam dynamics at CR", in Proc. International Workshop on Antiproton Physics and Technology at FAIR (FAIR '15, fair15.inp.nsk.su), Novosibirsk, Russia, Nov. 2015.
- [5] O. Gorda et al., "Beam Dynamics and Closed Orbit Correction at the Collector Ring", presented at IPAC'16, Busan, Korea, May 2016, paper THPMB002, this conference.
- [6] P. Shatunov et al., "The Injection Septum Magnet for the Collector Ring", presented at IPAC'16, Busan, Korea, May 2016, paper TUPMB017, this conference.