



國家同步輻射研究中心
National Synchrotron Radiation Research Center

Fast Orbit Feedback Scheme and Implementation for TPS

Pei-Chen Chiu

May 14, 2013

National Synchrotron Radiation Research Center

Hsinchu, Taiwan

NSRRC

Outlines

1. FOFB infrastructure
2. BPM & FOFB computation module
3. Corrector power supply & CPSC interface
4. Simulation
5. Summary

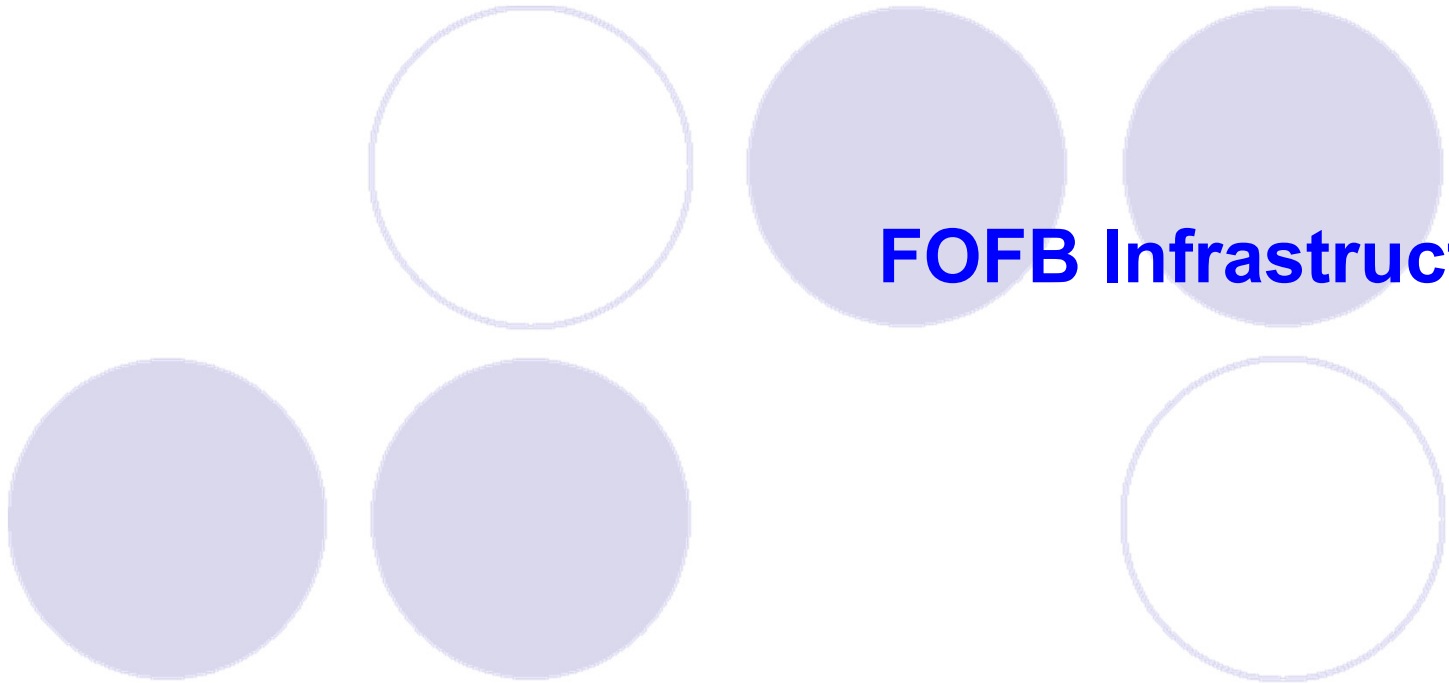

FOFB Infrastructure

Orbit Stability Requirements of the TPS

Beam size $\sigma_{x,y}$ and beam divergence $\sigma_{x',y'}$, for 1 % coupling, 24P79H2 configuration. Natural horizontal emittance is 1.6 nm-rad.

Source point	σ_x (μm)	$\sigma_{x'}$ (μrad)	σ_y (μm)	$\sigma_{y'}$ (μrad)
12 m straight center	165.10	12.49	9.85	1.63
7 m straight center	120.81	17.26	5.11	3.14
Dipole (1 degree source point)	39.73	76.11	15.81	1.11

Rules of thumbs for vertical orbit stability:

$\sigma_y/10$: $\sim 0.5 \mu\text{m}$ stability is required.

or further

$\sigma_y/20$: $\sim 0.25 \mu\text{m}$ stability is required.

Reference:

1. Paragraph of “Accelerator” in the TPS Design Handbook

Infrastructure for FOFB

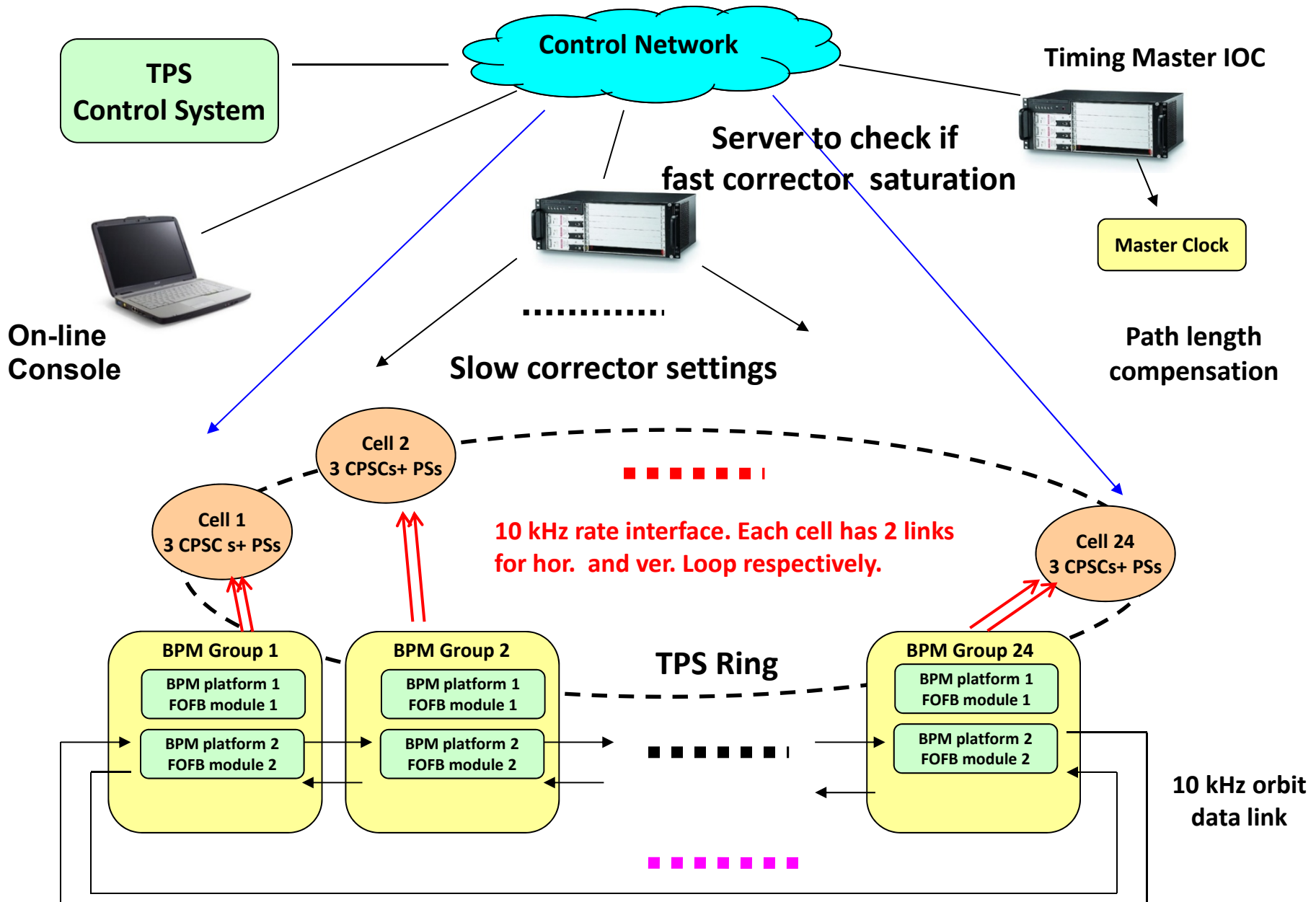

Major Components for FOFB in one cell



Fast Corrector (Installed at Bellows Site)

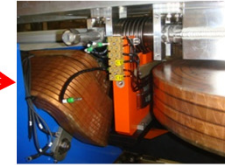

Fast Corrector Power Supply (Fast)

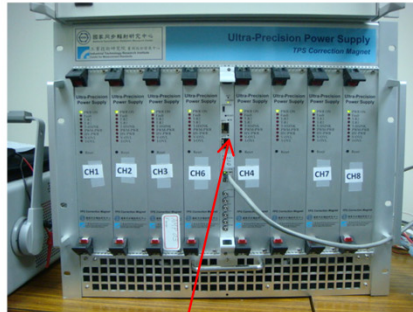

BPM Platform

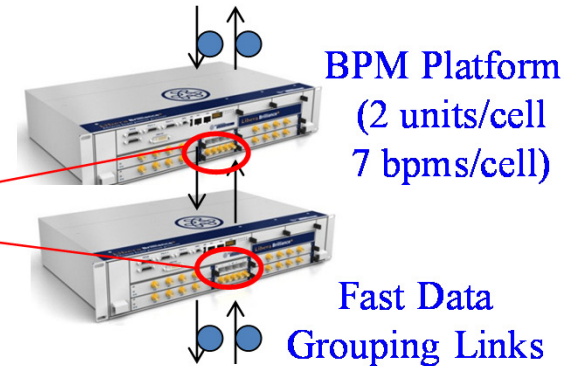

Correcor Power Supply Controller (EPICS IOC with Fast Setting FPGA Design)

Fiber Link

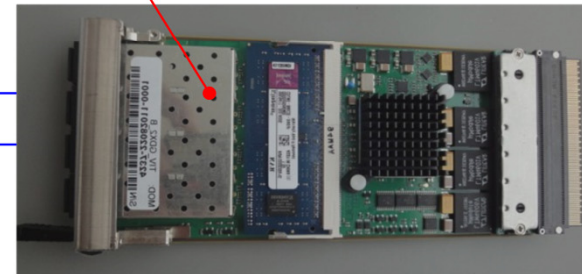

FOFB computation modules (also grouping data)



BPM & FOFB Computation Module

Beam Position Monitor

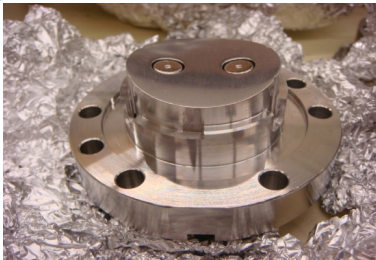
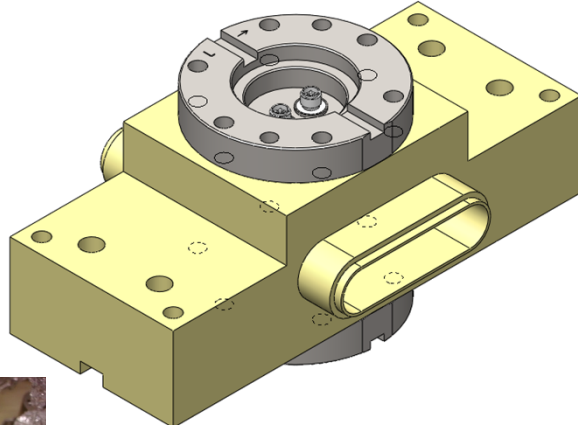
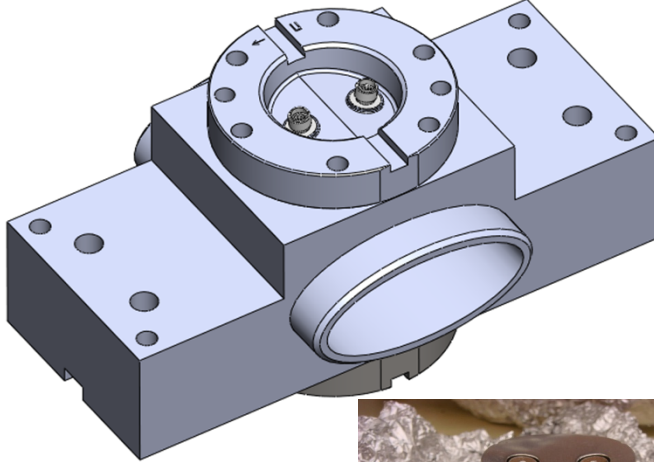
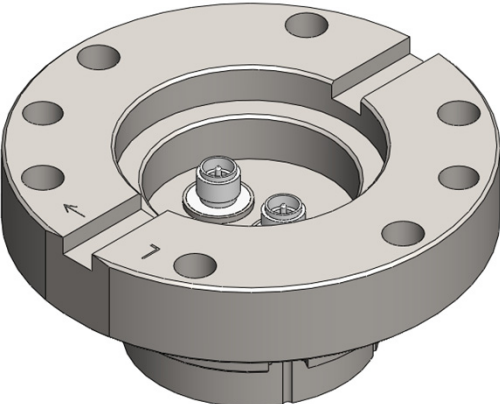

One cell

BPM*7
Fast corrector*4

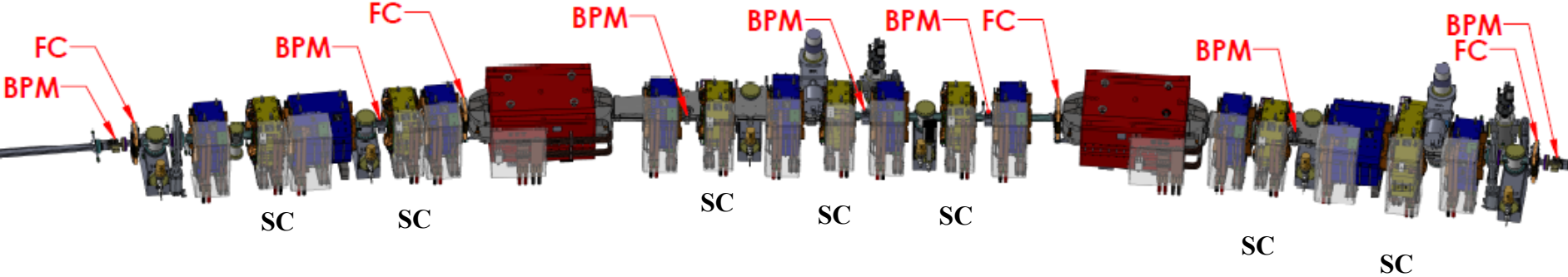

Slow corrector*7

BPM Electronics

- **Libera Brilliance Plus.**
- **76 units (60 booster & 168 SR BPM)**
- **ICB + BPM + Timing + GDX modules**
- **GDX support BPM grouping & FOFB functionality**

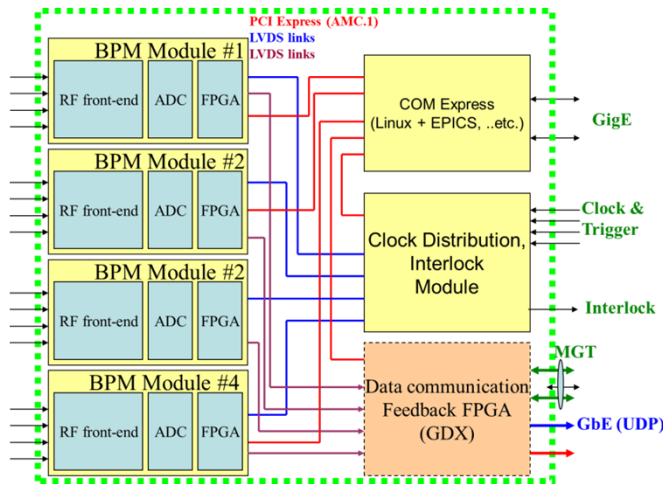

specification & measured performance

Parameters	Beam Charge/Current Range	Spec. (in rms)	Measured (in rms)
Single pass and sensitivity resolution	100 pC	< 1 mm	0.2 mm
Turn-by-turn resolution	0.5 mA	< 1 mm	0.15 mm
	10 mA	< 100 μ m	10 μm
	500 mA	\sim 1 μ m	1 μm
Resolution (10 Hz update rate)	0.5~10 mA	< 1000 nm	80 nm
	100~500 mA	< 100 nm	20 nm
Resolution (10 KHz update rate)	100~500 mA	< 200 nm	100 nm
Beam current dependence	100~500 mA	< 1000 nm	200 nm
Filling pattern dependence	100~500 mA	< 1000 nm	200 nm
Temperature dependence		<1000 nm/°C	\sim 100 nm/°C

One hour stability test

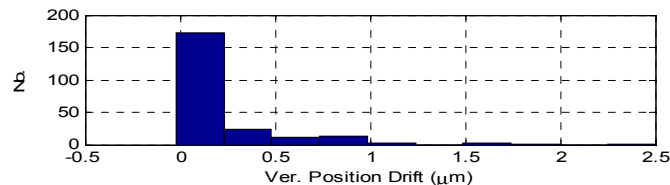
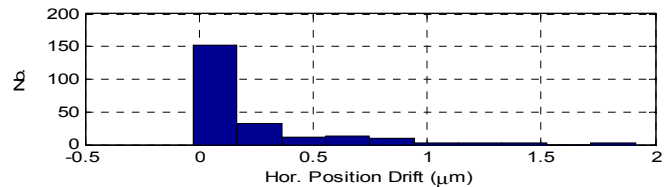

10 hz resolution

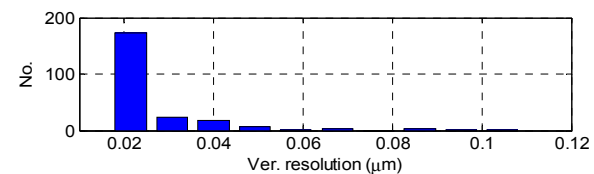
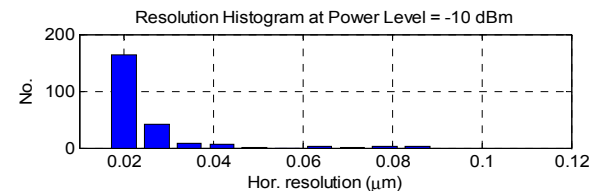

Block of FOFB computation modules

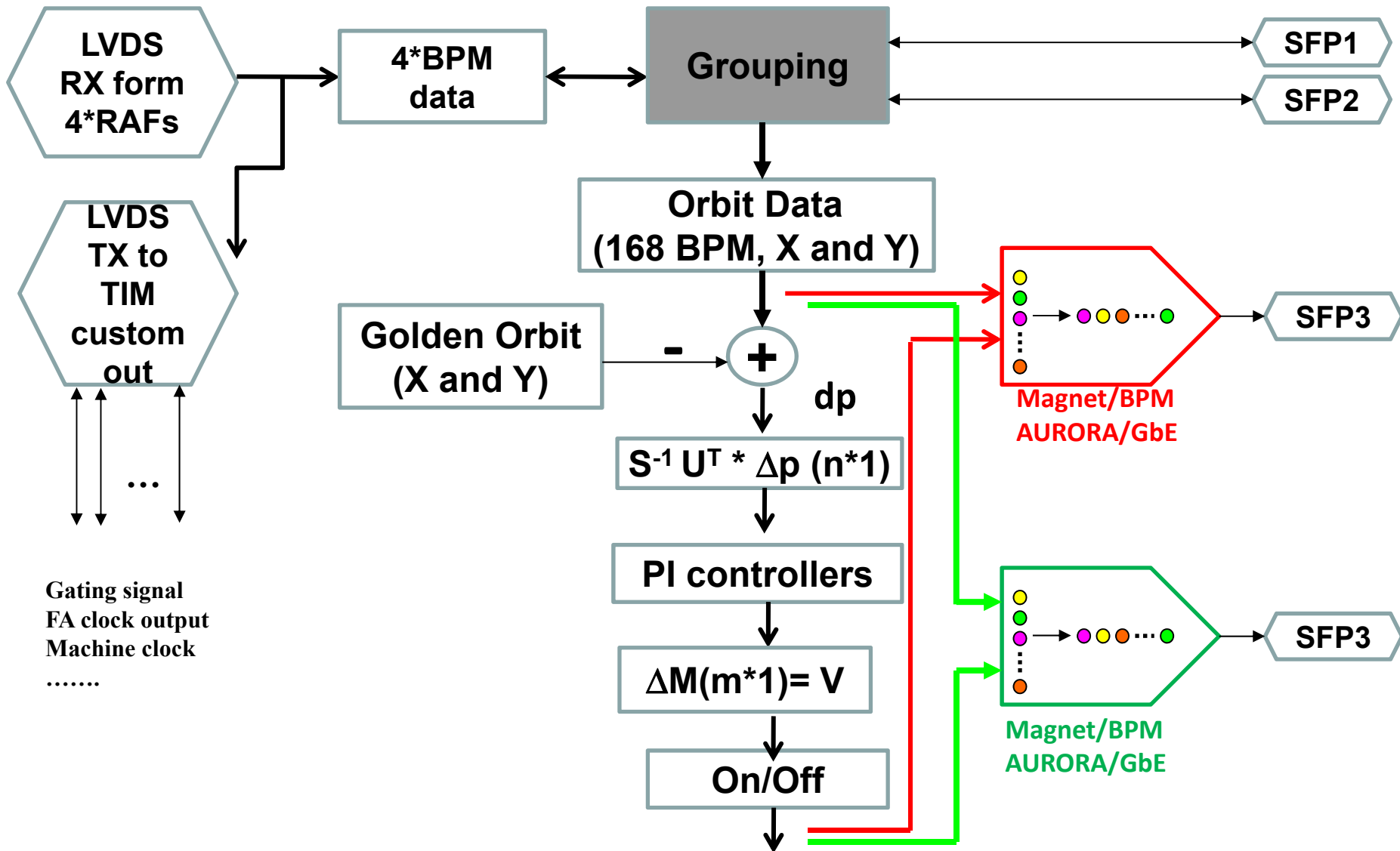



Corrector Power Supply & CPSC

Corrector Power Supply

- Switching power supply with analogue regulator. $\pm 10\text{A}/\pm 48\text{V}$
- Designed in- house.
- Used for both slow and fast correctors.
 - Slow correctors: control resolution & low noise level
 - Fast correctors: fast response.
- Two different controller and current sensors for slow (DCCT) and fast correctors (current sensing shunt resistor).
- Same control interface: CPSC(corrector power supply controller)



For slow corrector

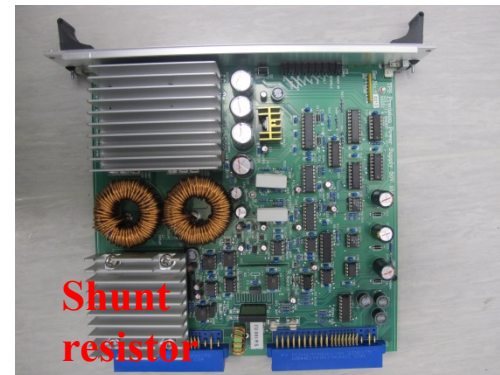

For fast corrector

Corrector Power Supply Controller (CPSC)

- The corrector power-supply controller (CPSC) :
 - (1) Computer
 - (2) Xilinx Spartan-6 FPGA
 - (3) ADC
 - (4) DAC
 - Slow access for the EPICS clients.
 - Fast settings from orbit feedback system or the feedforward application such as skew compensation through SFP port.
- Waveform reading & writing
- DI/DO for timing, fault detect, and so on.
- Contracted to D-TACQ.

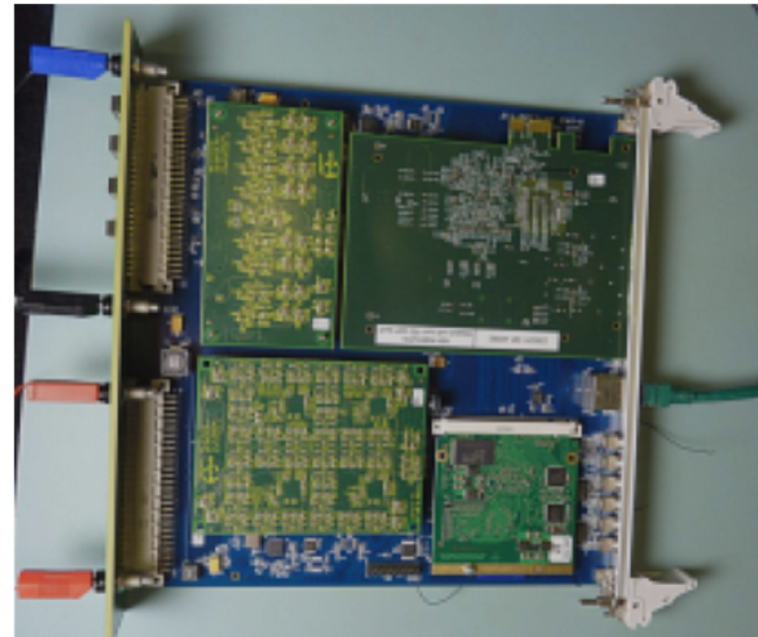
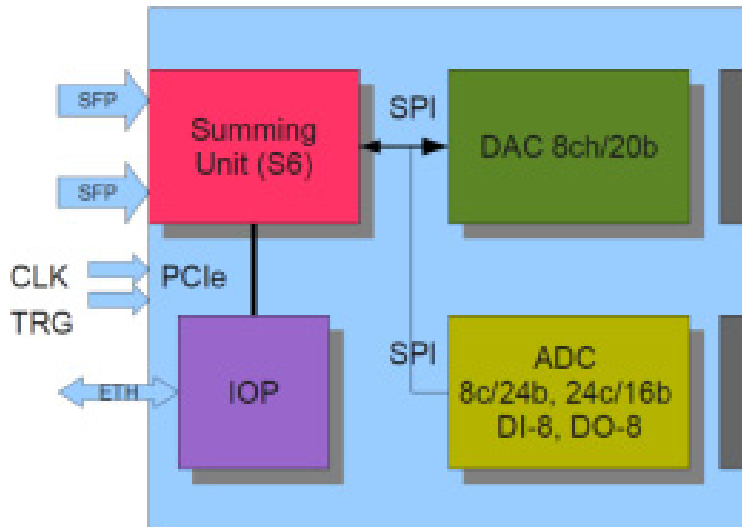

Power Supply Measurement

- 19 bit resolution achieve.
- Noise level is around -120 dB and would contribute <200 nm RMS orbit disturbances for total 168 slow correctors from DC~1kHz.
- Fast corrector ~ 1.3 kHz bandwidth.
- 10 hour stability rms ~ 5 uA.

1bit step change

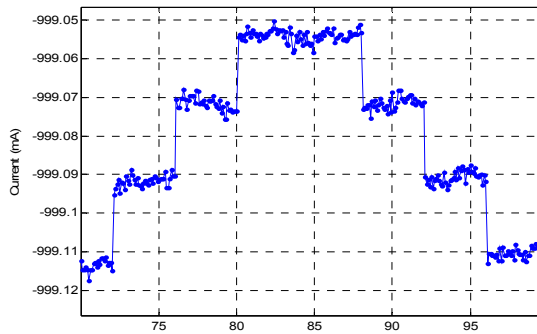

10 hour stability

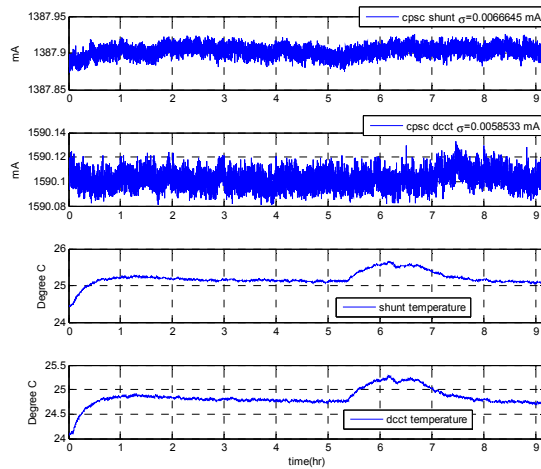

Noise level

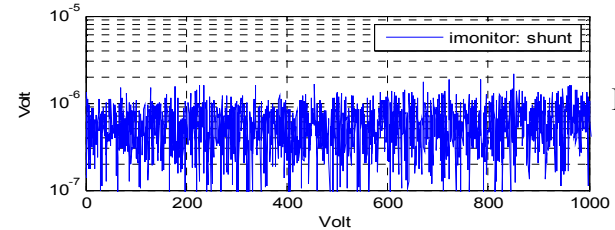

Fast corrector

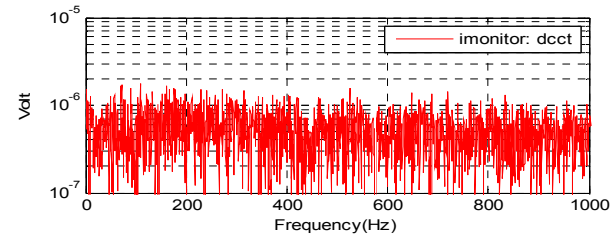

Slow corrector

Step response

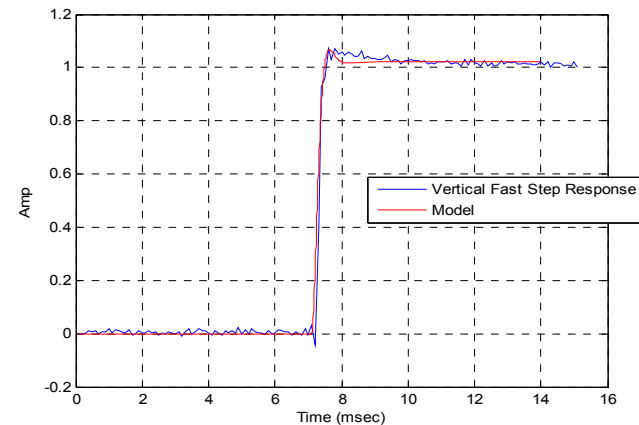

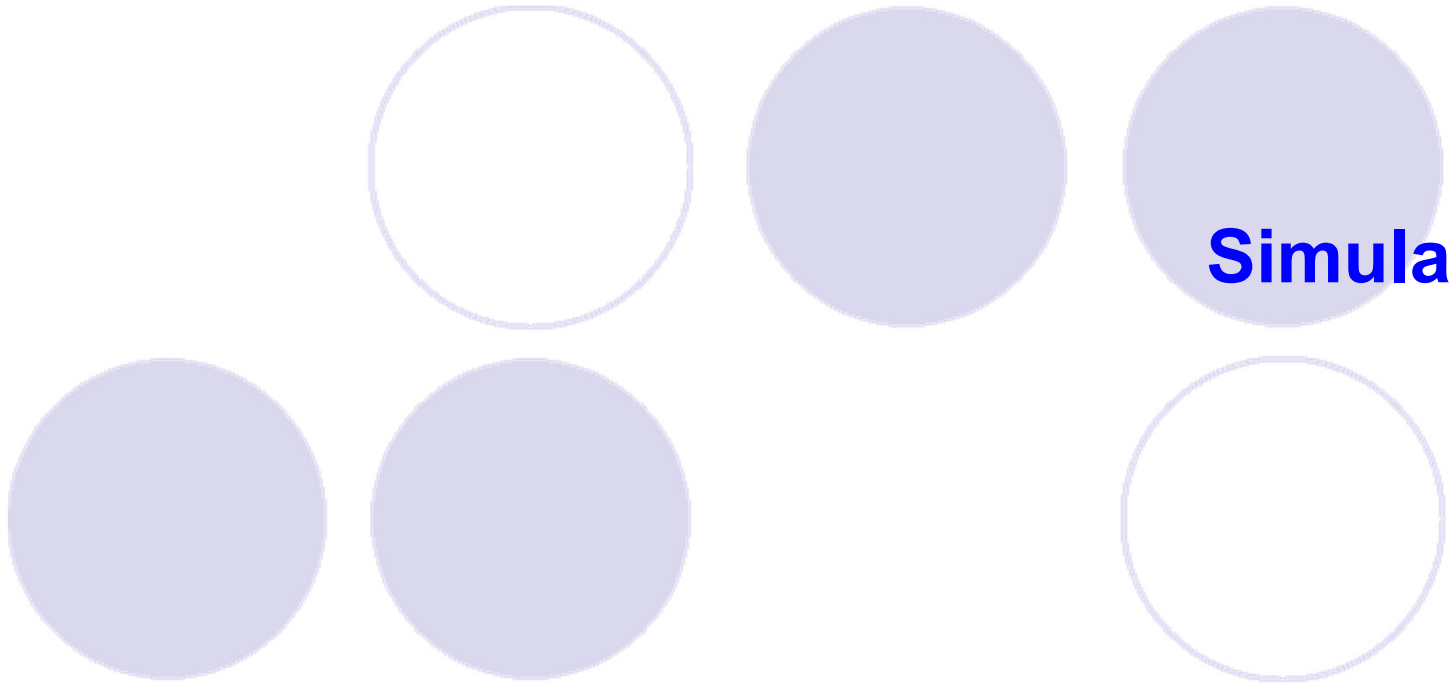

Simulation

Orbit Feedback Loop Simulation

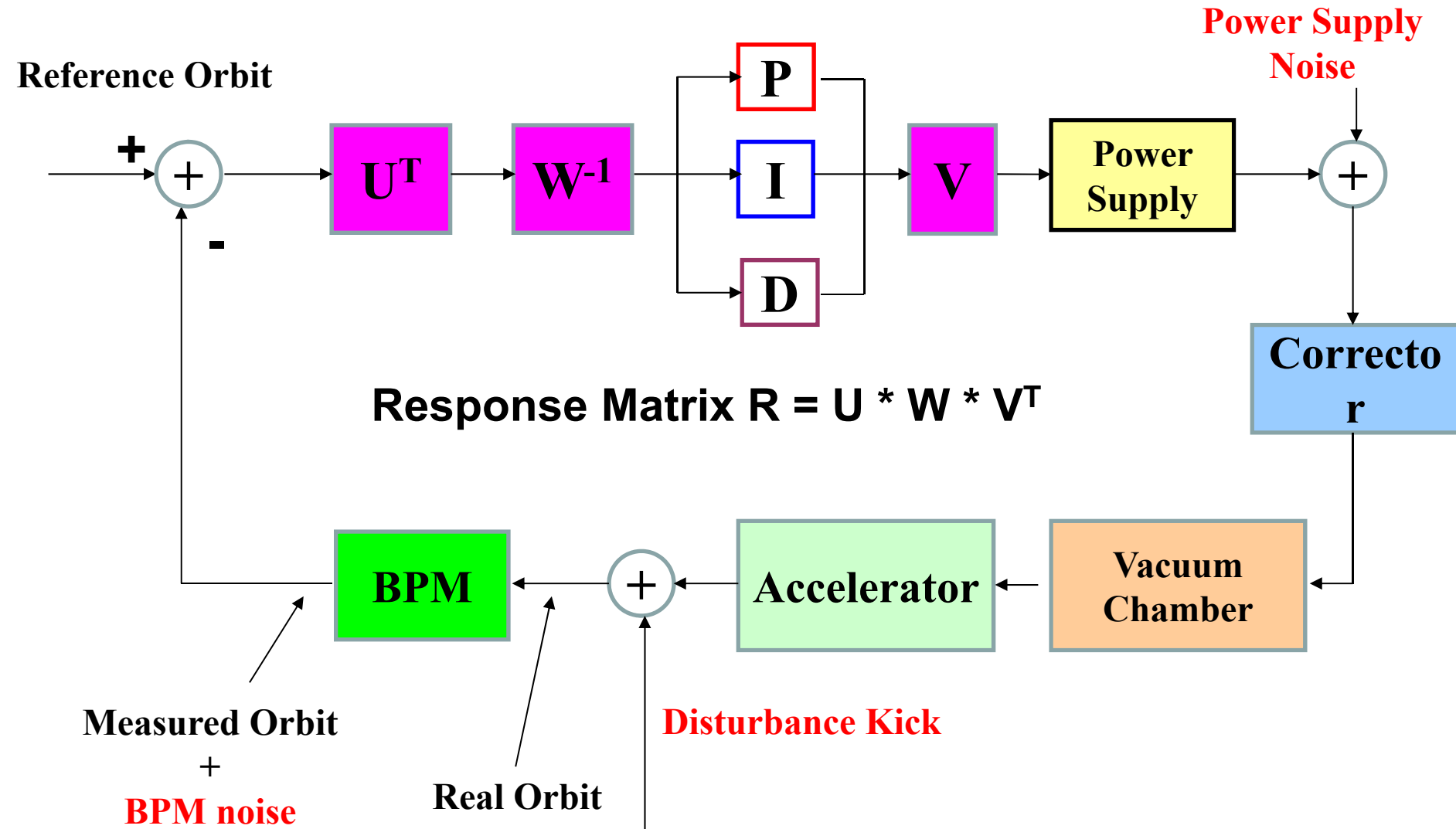

Static Simulation Results

Case 1: 7 bpms used for FOFB ~ 300 nm COD at straight line

~ 600 nm at bending section

Case 2: 5 bpms used for FOFB ~ 300 nm COD at straight line

~ 1000 nm at bending section

➤ **200 sets of random quadrupole displacements is taken.**

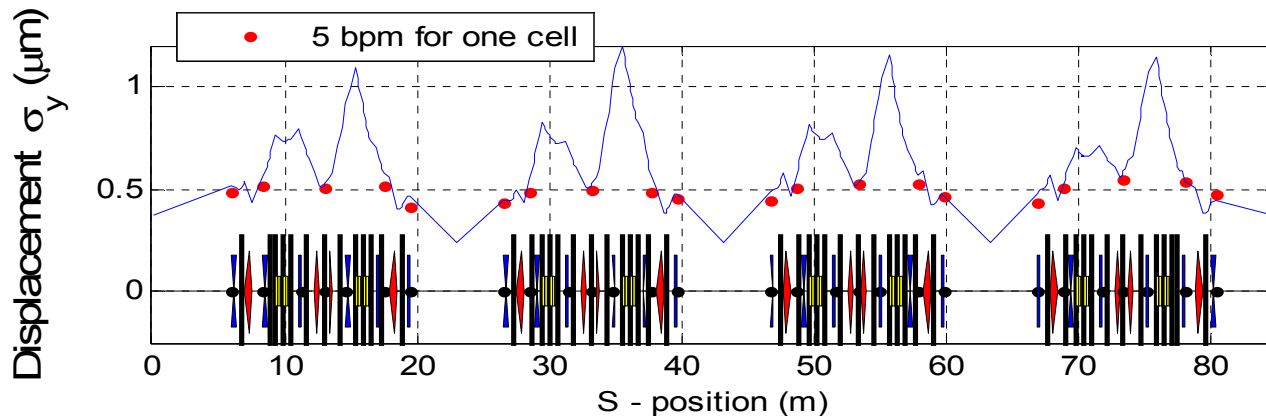
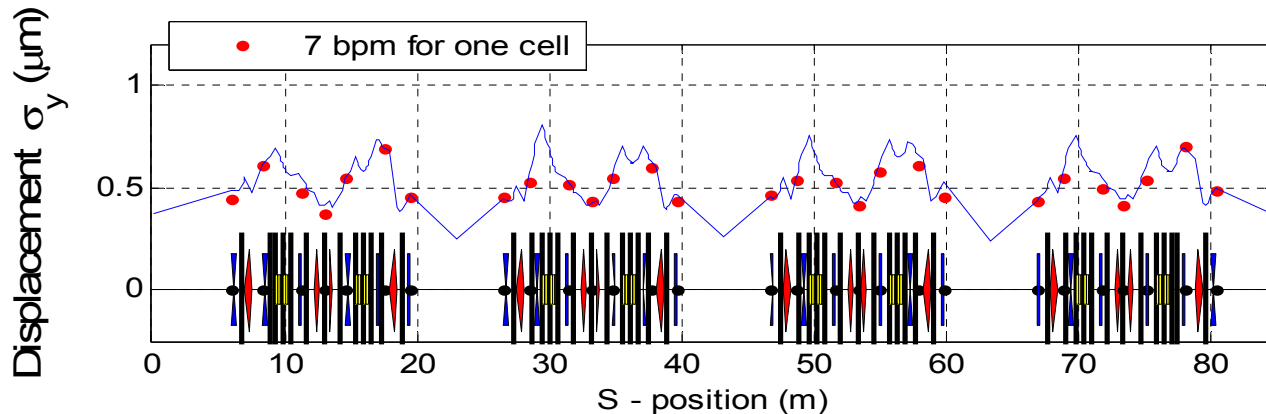

Noise Sensitivity Function

Sensitivity function = $|1/(1+ G_{\text{transfer function}})|$

- Corrector bandwidth = 300 Hz
- PS bandwidth = 1.3 kHz
- Vacuum Chamber bandwidth = 500 Hz
- Noise suppression bandwidth is around 300 Hz.

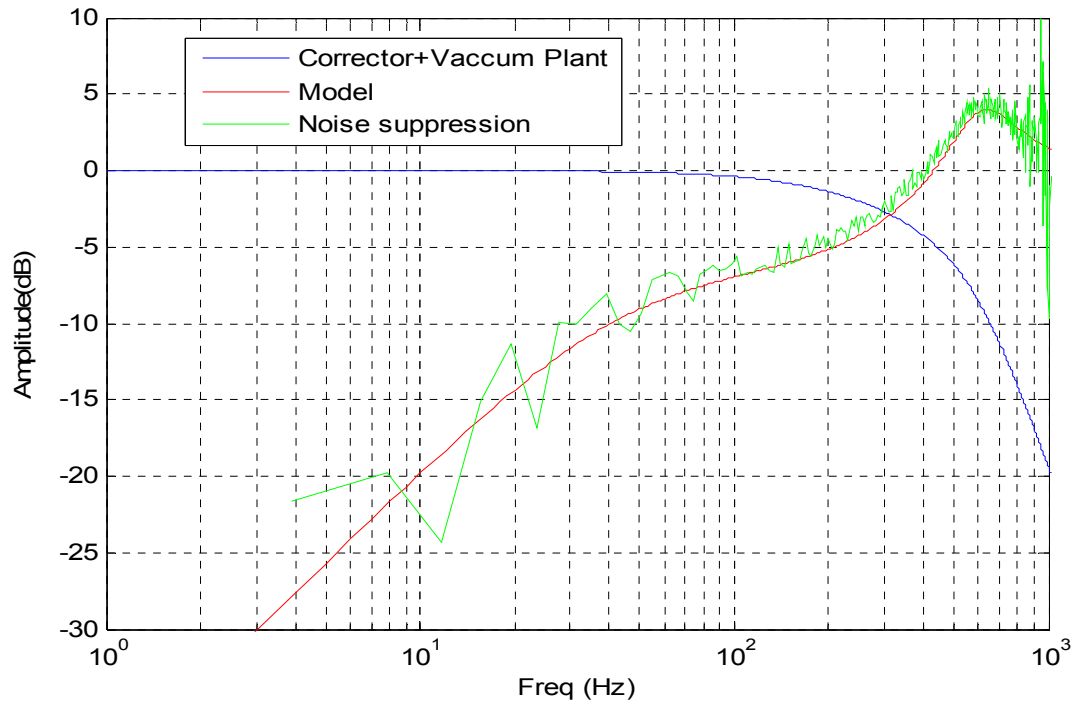

3dB B.W. ~ 300 Hz

Schemes to deal with slow & fast correctors

- SOFB at beginning, then FOFB later, running FOFB only!
- SOFB and FOFB running as two independent system. Some with frequency dead-band



- FOFB run from DC, a slow system receives the fast correctors from their DC part to prevent saturation.

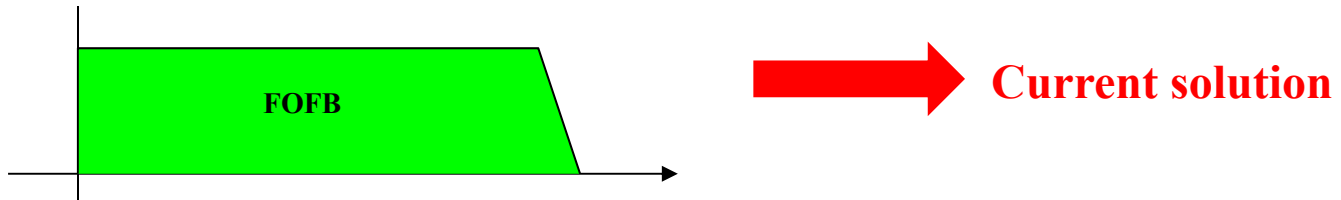

- Orbit feedback system with combined fast and slow correctors

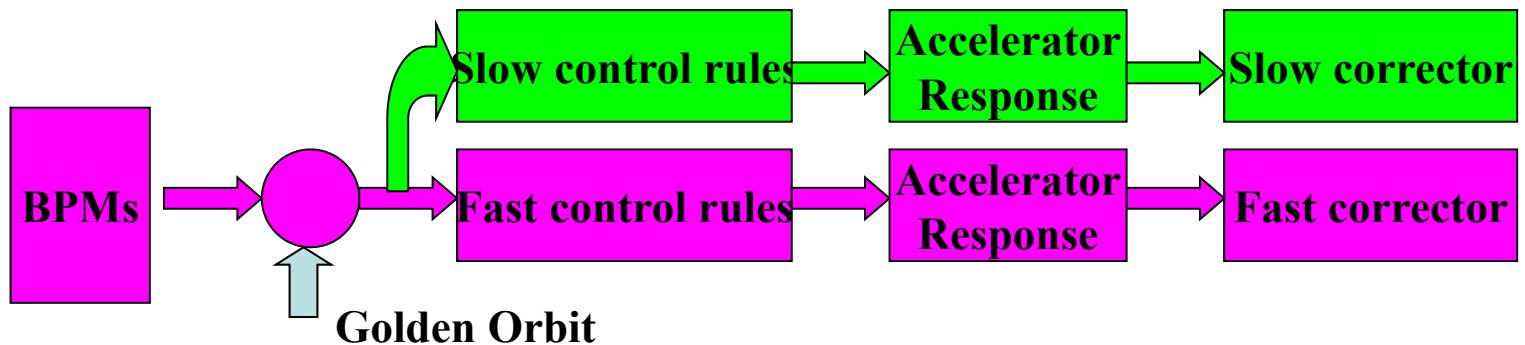

Orbit disturbance when correction transfer

- The transaction when DC part of fast corrector transfer to slow corrector.
- At 50 msec, a kick (~ 120 nrad) cause orbit excursion and soon FOFB suppress it in 10 msec and it results in one corrector (fast VC011) has 60 mA DC offset.
- At 100 msec, the nearby slow (slow VC011) take DC parts of the slow correctors and fast corrector decreasing to zeros.
- The transaction between slow and fast will only cause orbit disturbance less than 1 μm and vanish in 10 msec.

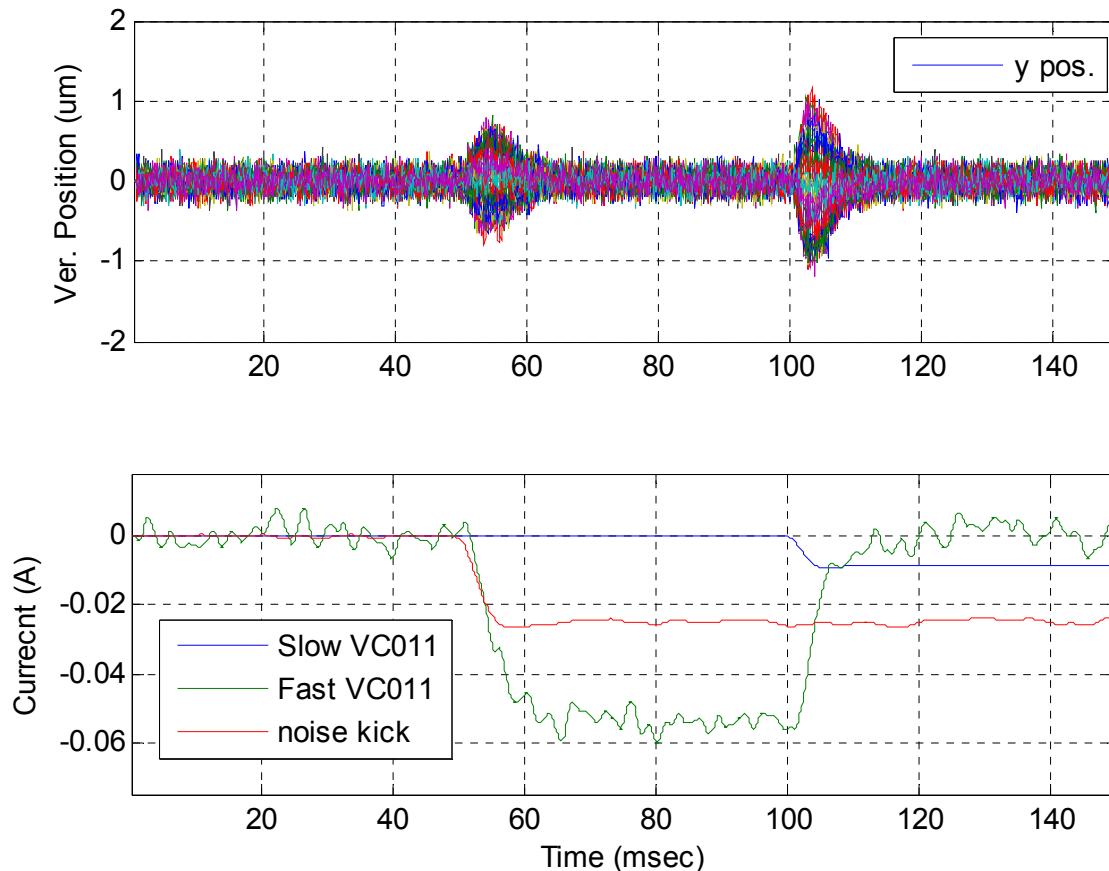

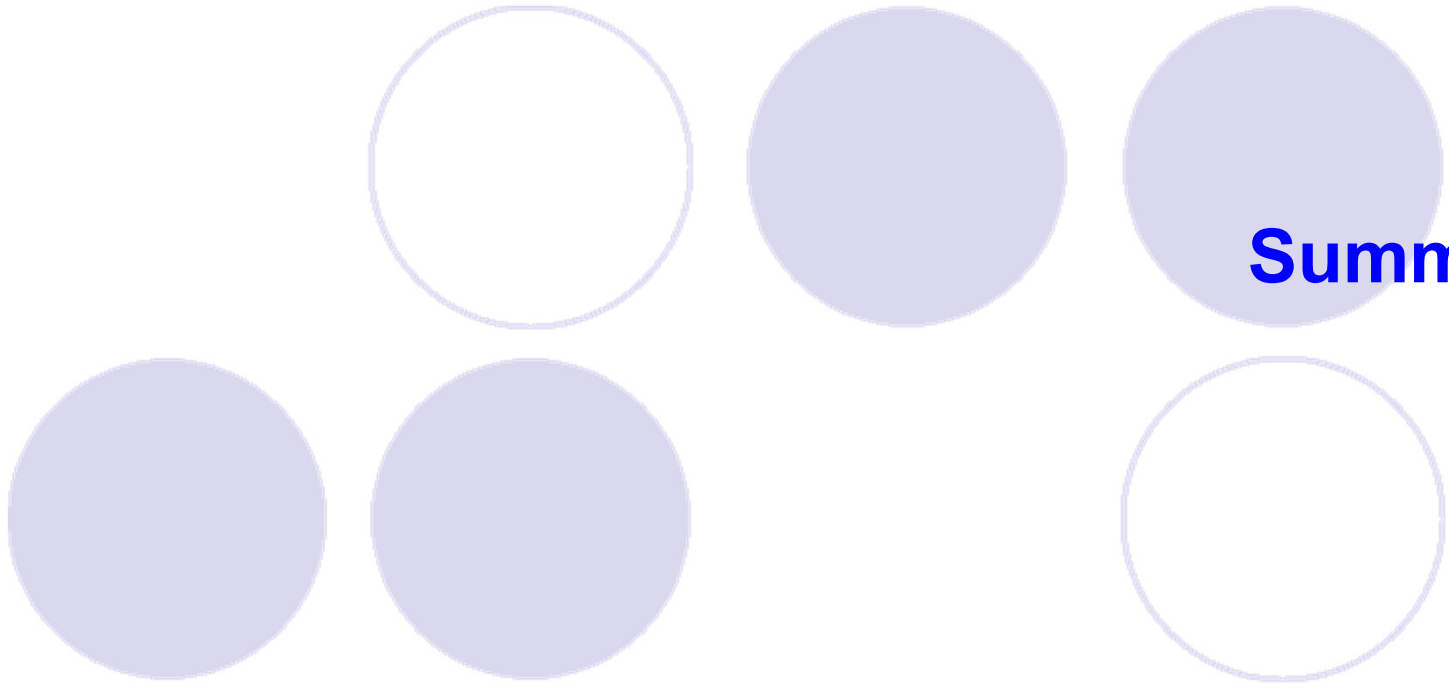

Summary

Summary

BPM

**New generation digital BPM electronics ready for install
20 nm resolution for 10 Hz; 100 nm resolution for 10 kHz**

Corrector power supply

Analogue switching power supply

~ -120 dB noise level

> 18 bit control resolution

~ sync by external trigger

fast setting from FOFB

slow setting for EPICS clients

FOFB scheme

Fast orbit feedback => 10 kHz update rate, 300 Hz bandwidth, run from DC

Latency: 10 usec (BPM) + 2 usec (computation) + 2 usec (fiber) ~15 usec

Slow corrector compensation

Thank You for Your Attention!