

100 MeV / 100kW Electron Linear Accelerator Driver of the NSC KIPT Neutron Source

Yunlong Chi, Andrey Yuriy Zelinsky, Shilun Pei
On Behalf of the KIPT Linac R&D Team
May 16, 2013 at IPAC'13, Shanghai



IPAC 上海 **13**
The 4th International Particle Accelerator Conference
第四届国际粒子加速器会议

Shanghai China
12-17 May 2013
Shanghai International Convention Center



Outline

- @ Introduction
- @ Beam Dynamics Study
- @ Injector Testing Facility
- @ Sub-systems and Main Components
- @ Summary

Introduction

- ② The 100MeV/100kW linac will be used as a driver of a neutron source based on a subcritical assembly. The main functions of the subcritical assembly are to support the nuclear industry and medical research. Reactor physics and material researches will be carried out.
- ② The neutron source is a joint project between KIPT (Kharkov Institute of Physics and Technology, Ukraine) and ANL (Argonne National Laboratory, USA), and the Linac including the beam transport line to the target is being constructed by IHEP (Institute of High Energy Physics, China).
- ② Due to the high average beam power, low beam losses along the entire Linac is demanded, thus construction of such an accelerator with high average beam power and low beam power losses is a technical challenging task, and all components of the machine have to be designed, fabricated, tested, assembled and commissioned elaborately.

Introduction

- ④ In 2012, the injector testing facility was pre-installed in the experimental hall #2 of IHEP, and the beam and key hardware are tested with satisfying results. In the meantime, the performance of some hardware was also improved by modifying the initial design.
- ④ Recently, the injector testing facility was disassembled and all of the components for the whole Linac have been shipped to KIPT from China by ocean shipping.
- ④ In early June, the machine will be assembled in KIPT by IHEP team collaborated with KIPT team, hopefully the accelerator conditioning and commissioning will be started soon.

Facility Conceptual Overview



Sub-critical Assembly and Transport Line

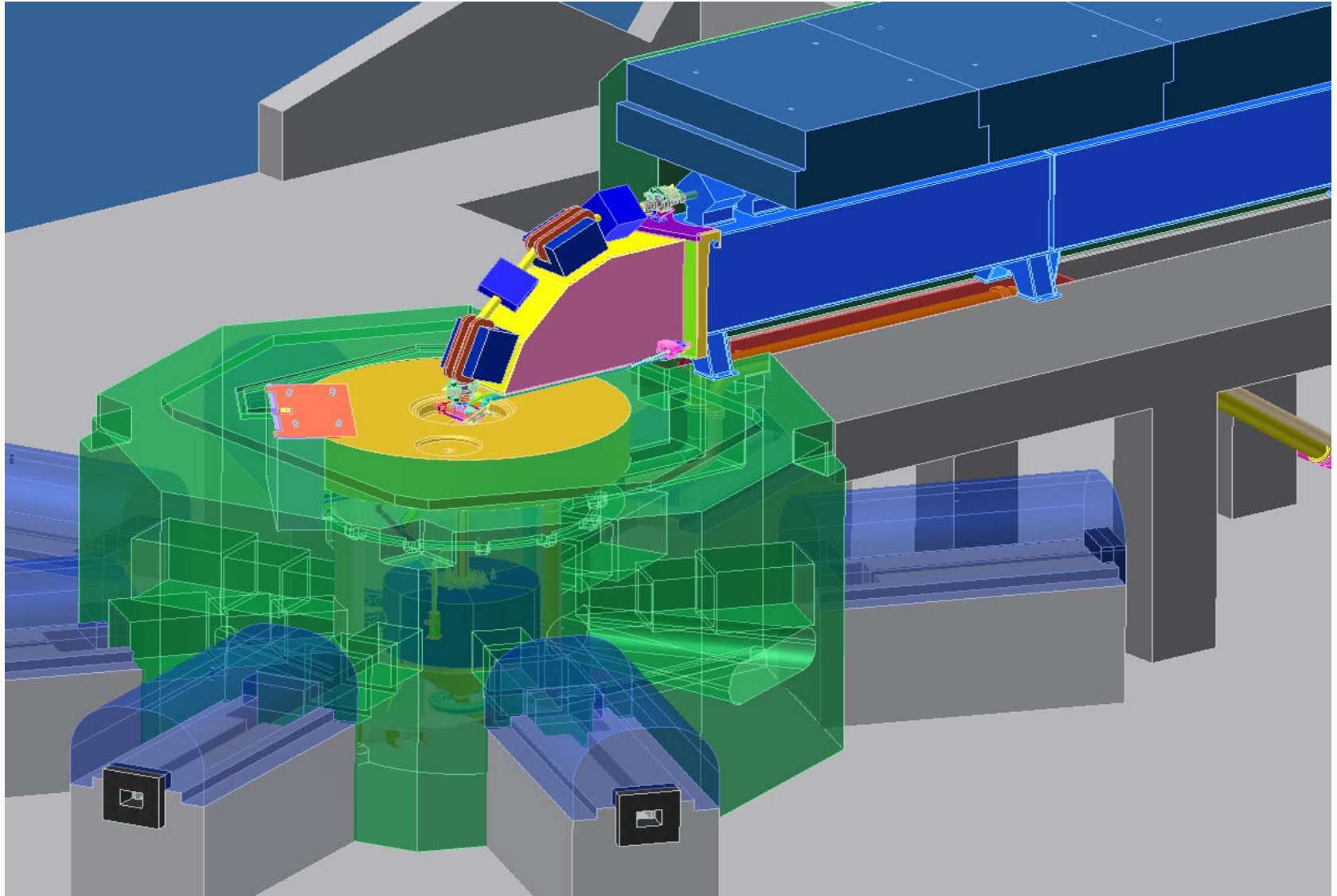

Linac Layout and Parameters

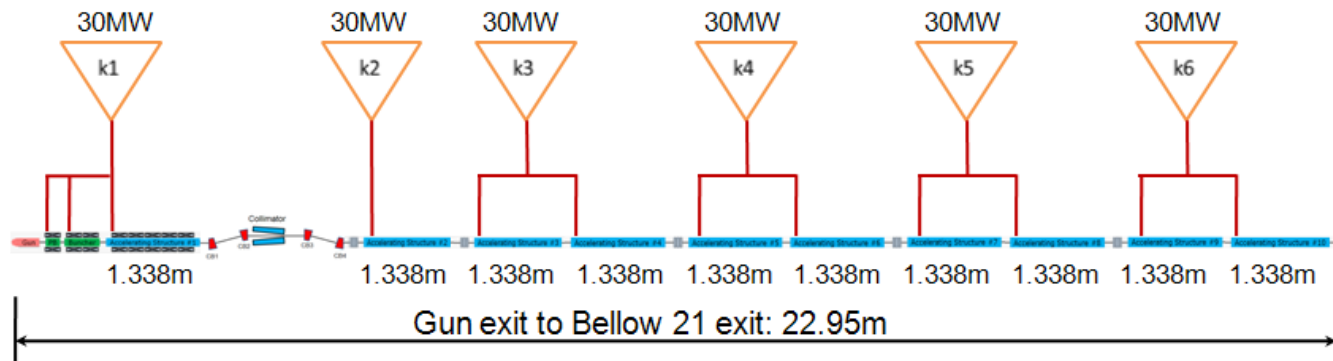

Parameters	Values	Units
RF frequency	2856	MHz
Beam energy / power	100 / 100	MeV / kW
Beam current (max.)	0.6	A
Energy spread (p-to-p)	± 4	%
Emittance	5×10^{-7}	m-rad
Beam pulse length	2.7	μ s
RF pulse length	3	μ s
Pulse rep. rate	625	Hz
Klystron	$6 \times 30\text{MW} / 50\text{kW}$	Units
Accelerating structures	$10 \times 1.336\text{m}$	Units
Gun high voltage	~ 120	kV
Nominal gun beam current	$\sim 1-1.2$	A

Chicane System

- ② To satisfy the peak-to-peak energy spread requirement at the linac exit, particles with large energy difference from the synchronous particle should be eliminated at the low energy stage to ease the design of the beam collimation system and the radiation shielding.
- ② A dispersion free chicane system with 4 bending magnets is introduced and located downstream the injector part but upstream the 2nd structure.

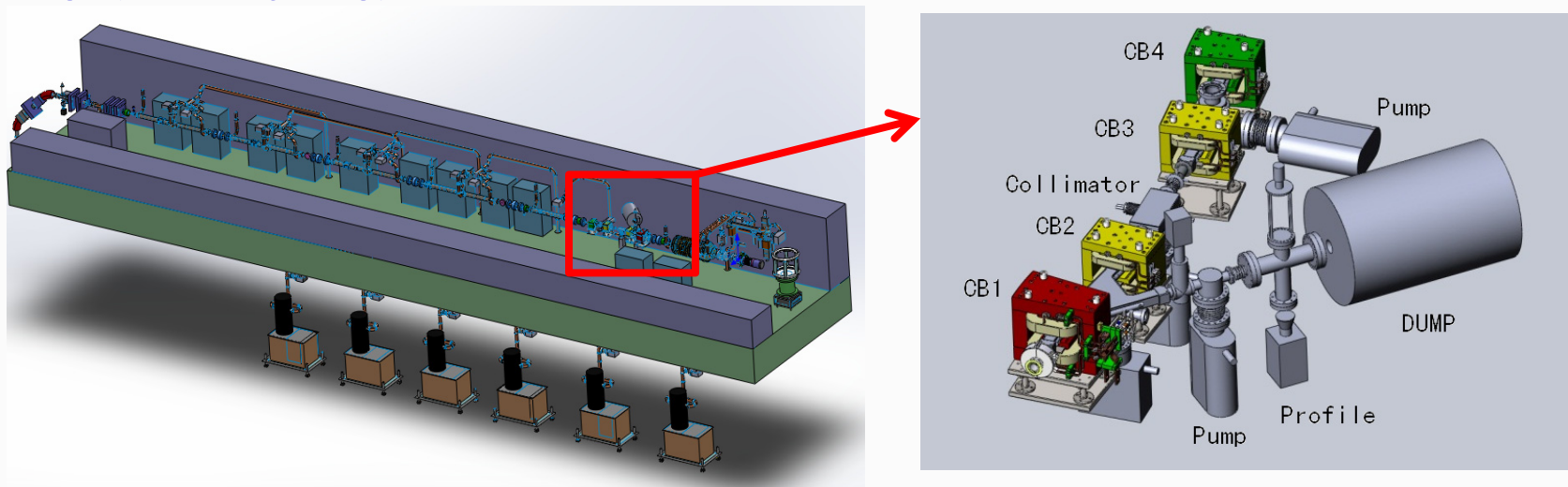

Mechanical layout of the whole linac including the beam transport line to the target and the Chicane system

Injector of the Linac

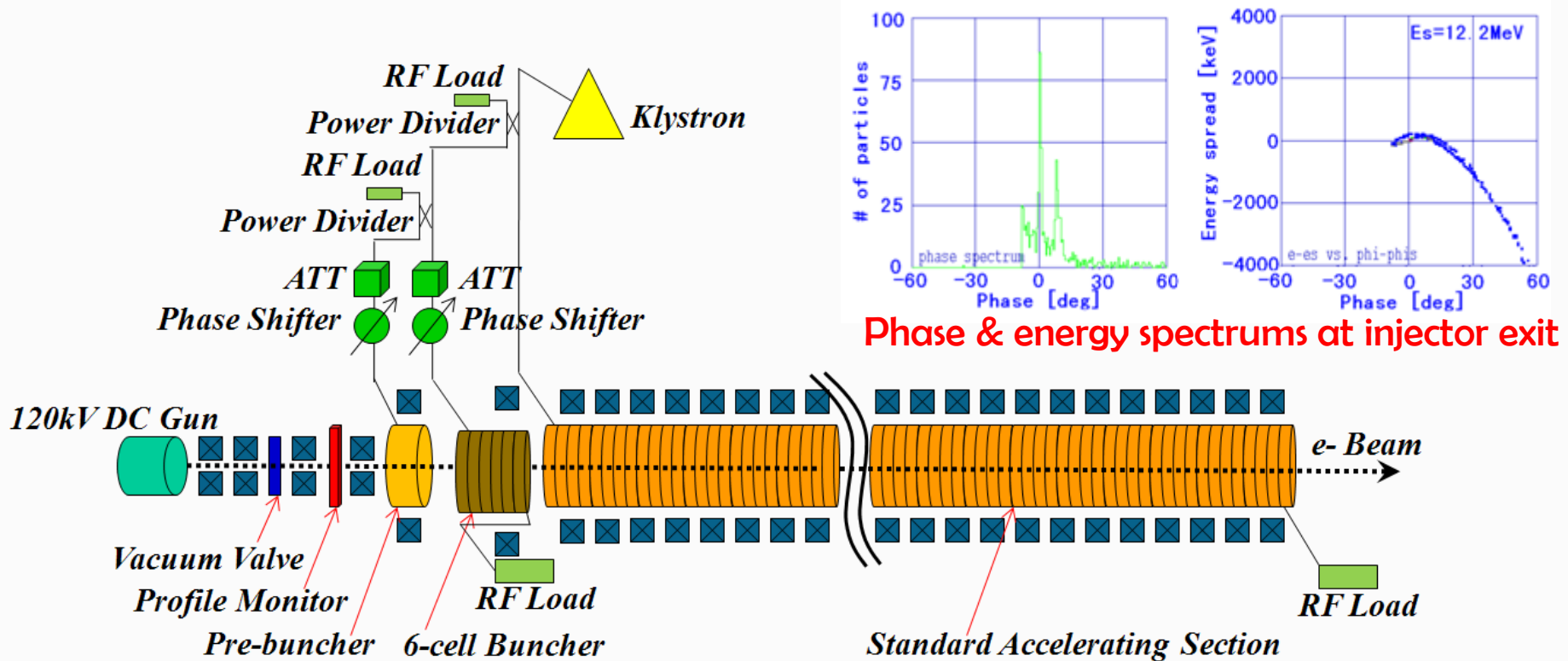

To get a clean bunch without any satellite electrons in each RF period downstream the chicane system, the phases of all the RF structures and the solenoid field along the injector are tuned to obtain the optimized phase and energy spectrums appropriate for the downstream beam collimation.

Error and Jitter Analysis

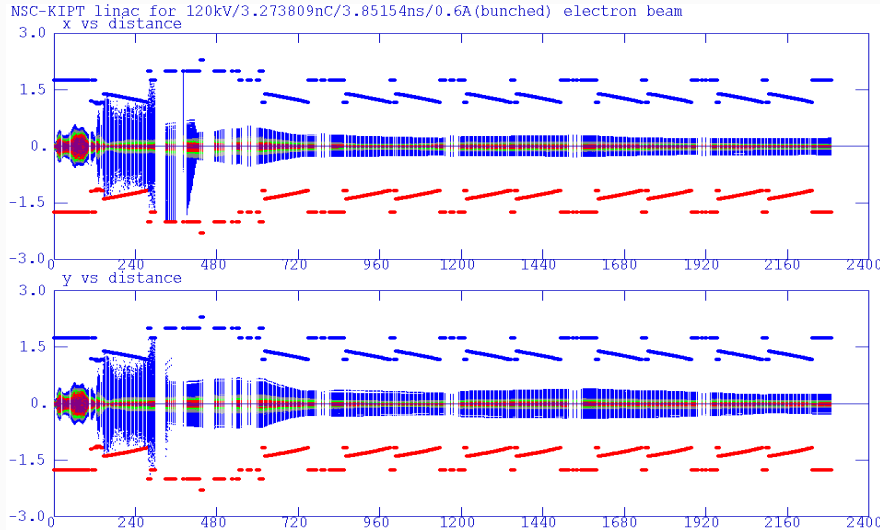

Beam envelope for ideal case

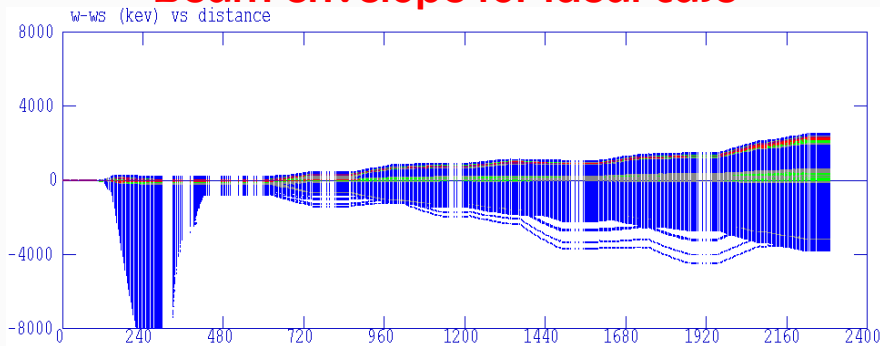

Energy spread for ideal case

For the nominal 100kW beam power, power loss along the transport line is ~700W with error and jitter effects.

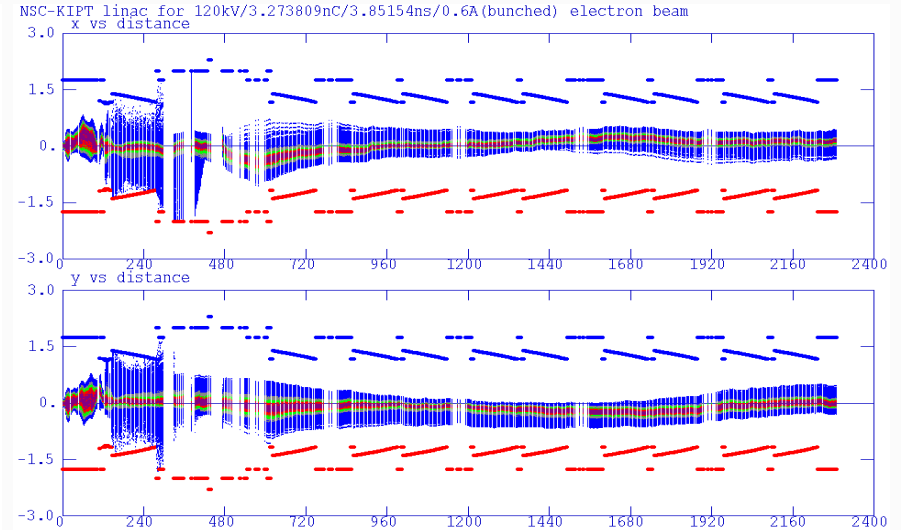

Beam envelope with error and jitter effects

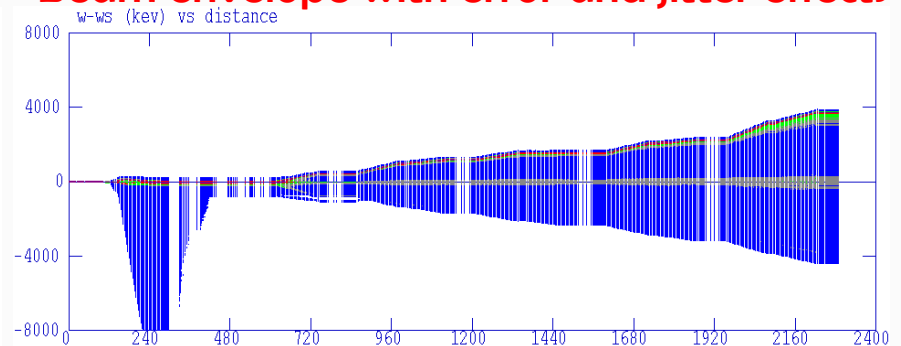

Energy spread with error and jitter effects

$\pm 0.2\text{mm}$ misalignment/ $\pm 2^\circ$ phasing error/ $\pm 0.15\%$ modulator voltage jitter/ 0.5% gun high voltage jitter/ $\pm 1\%$ RF flatness

BBU Effect Studies

- Because of the high beam pulse current (600mA) and long beam pulse length (2.7 μ s), BBU effect is very serious and need to be suppressed.

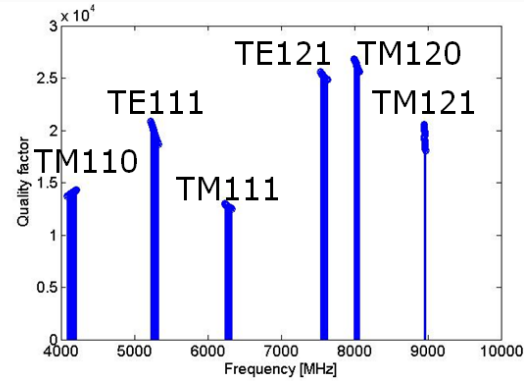
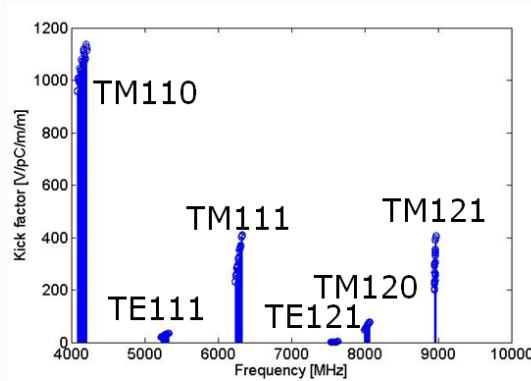

TM & TE Dipole modes' characteristics for the adopted accelerating structures

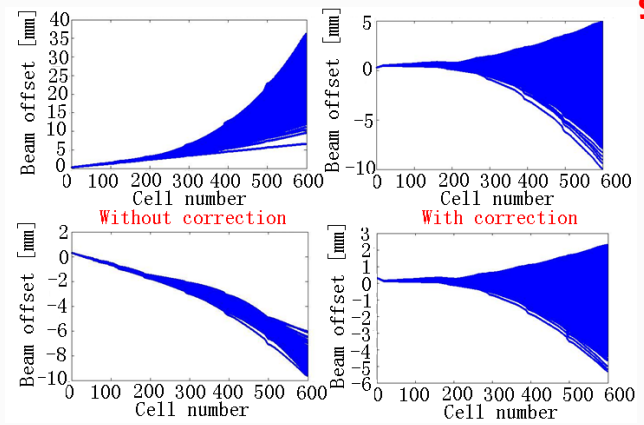

BBU calculation (300 μ m initial offset and 300 μ rad initial angle)

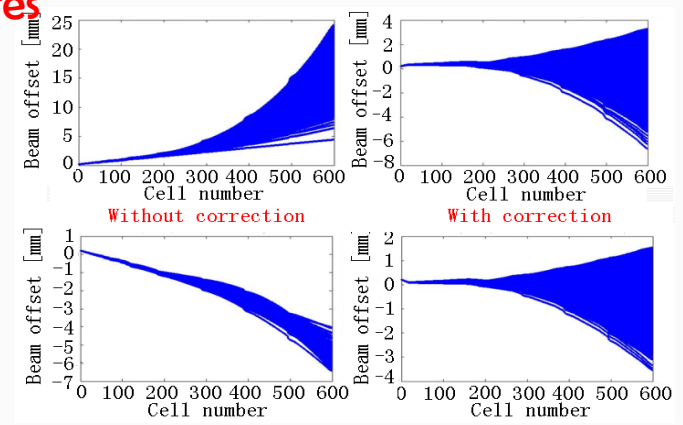

BBU calculation (200 μ m initial offset and 200 μ rad initial angle)

Beam Transport Line

- ② Two 45° vertical sector-type bending magnets B1 and B2 to bend the beam to the target. A quadrupole is placed at the middle point of the arc to cancel the dispersion.
- ② A triplet and another two quadrupoles are used to form the beam size on the target. The triplet is also used for emittance measurement together with PR3 by quadruple scanning method.
- ② Because of the uncertainty of the beam TWISS parameters at the linac exit, the triplet is also used for the emittance measurement together with the profile monitor PR3 by the quadruple scanning method.

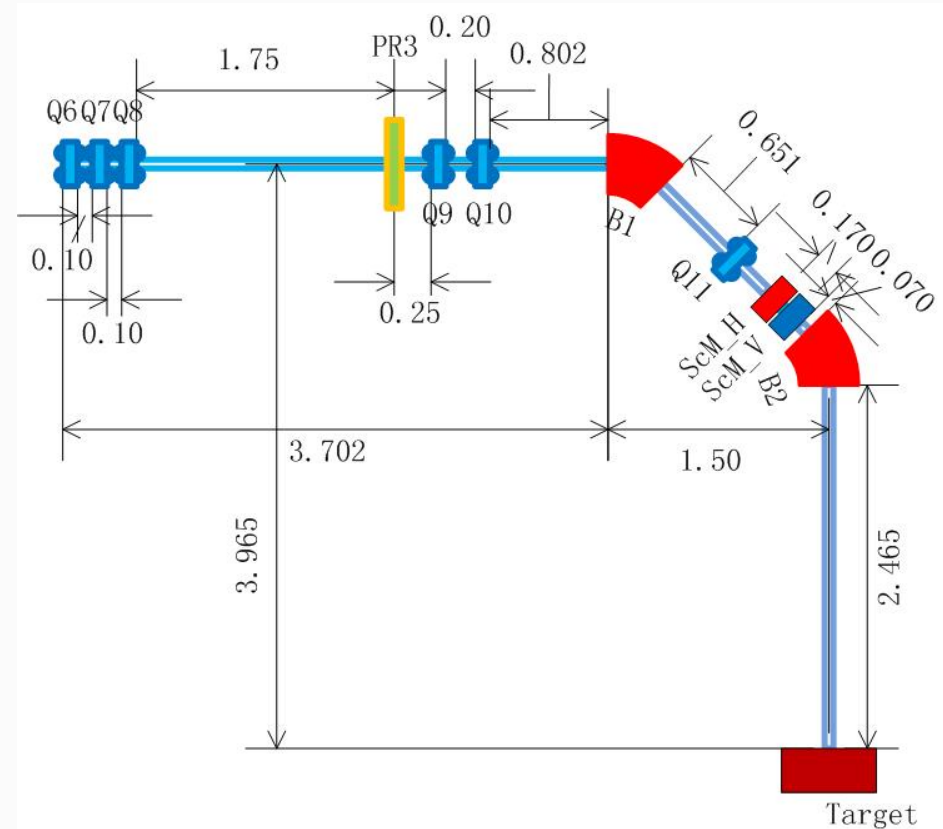

Beam Scanning System

- ④ The beam scanning system consists of two deflecting magnets.
- ④ The deflecting angles change from 0 to 35mrad to spread the beam pulses on the target evenly. The maximum repetition rate is 625Hz.
- ④ The scanning magnets deflect the beam pulses to 625 different places in 1 second, which means 25 horizontal and 25 vertical steps.
- ④ Because of the beam pulse time interval is very short (1.6 ms), the switching frequency of one magnet should be 12.5 Hz with saw tooth waveform (blue line in right figure). Another magnet strength switches with multi-step (red line in right figure), and the step is very steep (1.6 ms).
- ④ The beam density uniformity can reach ~5% at the target.

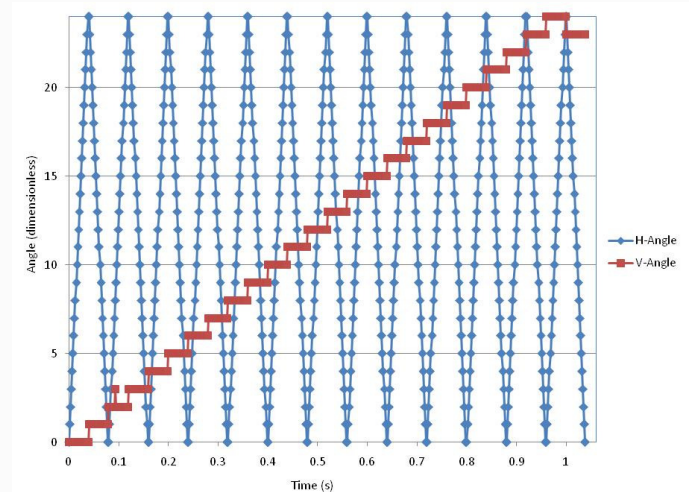
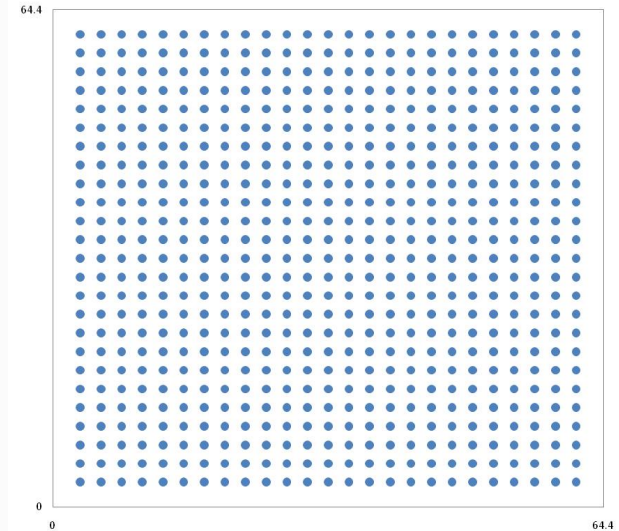

Injector Testing Facility



Tested in IHEP in 2012, disassembled recently.

Beam Testing Results

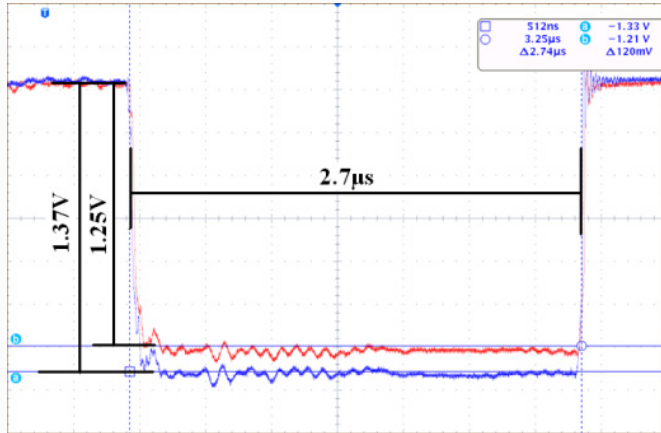

Beam pulse measurement by FCT

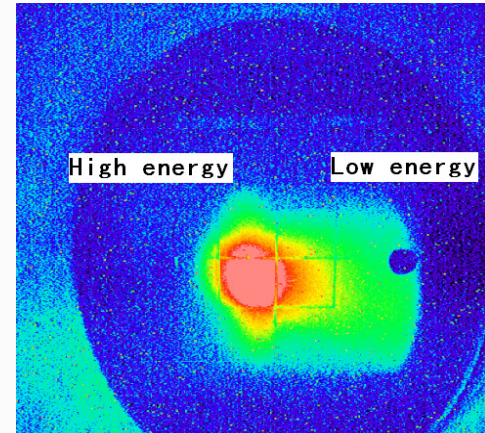

Profile at the energy measurement line

- ⊙ The maximum beam current obtained at the injector exit is ~2A with 2.7 μs pulse length, this is limited by the electron gun capability, no clear BBU effect observed for this scenario.
- ⊙ The measured energy spread is ~2% @ 1σ with ~90% transport efficiency at the nominal gun beam current of ~1.1A.
- ⊙ No clear high energy beam tails were found but only low energy tails, which means the electron beams provided by the injector are very appropriate for the downstream beam collimation.
- ⊙ It is believed that ~600mA beam can be successfully obtained at the main linac.

Electron Gun

Design Parameters

Parameters	Units	Value
Type	Triode	
Cathode (Dispenser)	EIMAC Y824	
Beam Current (Max)	A	2
Cathode Voltage	kV	-120
Filament Voltage	V	6.4
Filament Current	A	5.5
Grid Bias	V	50~400
Pulse Voltage	V	200~600
Pulse width (FWHM)	μ s	3.0

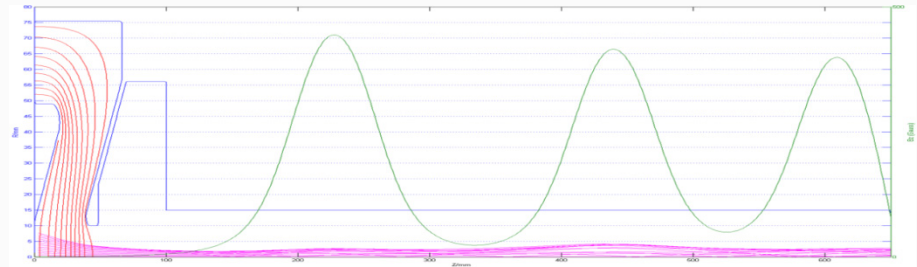

Beam optics

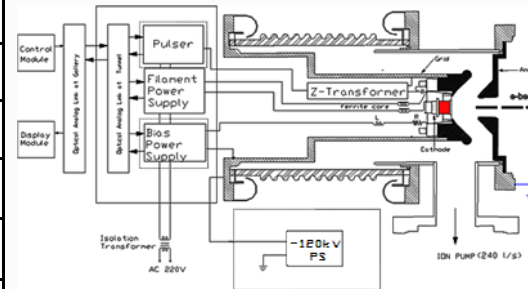

Circuit diagram

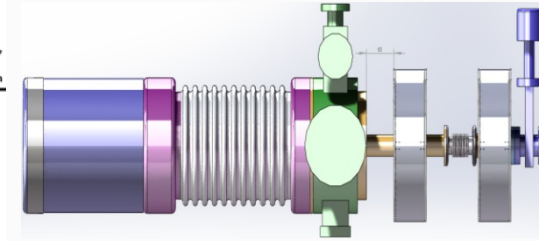

Gun & beam transport elements

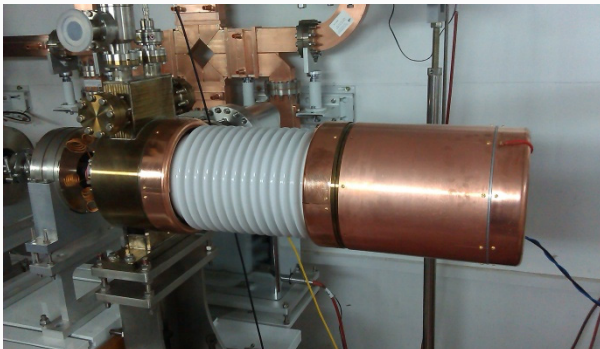

Gun @ IHEP tunnel



HV station (150kV Max)

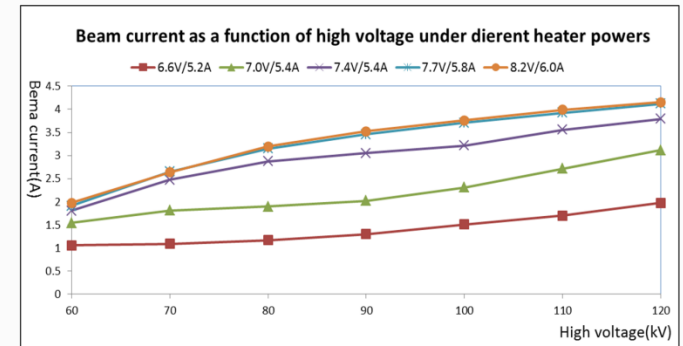

Testing results

RF Source

Klystron Parameters

Frequency	MHz	2856
Peak beam voltage	kV	258
Peak cathode current	A	271
Peak RF output power	MW	30
Average output power	kW	56
Efficiency	%	43
Gain	dB	53
Max. Pulse repetition rate	pps	625

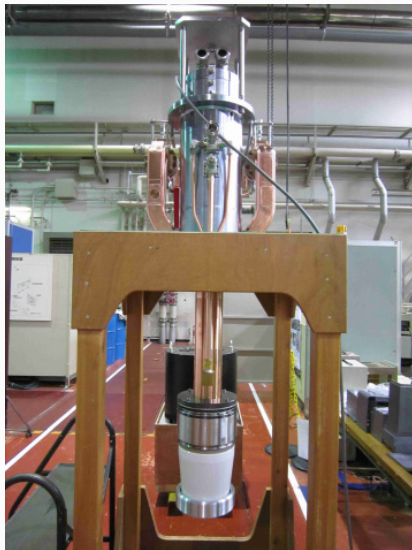

E37311 Klystron

Modulator Parameters

Peak Beam Voltage	kV	258
Peak Cathode Current	A	271
Max. Pulse repetition rate	pps	625
Flat-top length (at 100% amplitude)	μs	3.0
Beam voltage stability	%	± 0.15
Beam voltage ripple	%	± 0.15
Capacitive Voltage Divider		5000:1
Current transformer (50 Ω)	A/V	10
Pulse transformer turn ratio		1:12
PFN impedance	Ω	~ 6.5
PFN Charging Voltage	kV	~ 45
AC power frequency	Hz	50



Modulator @ IHEP

RF Source Testing

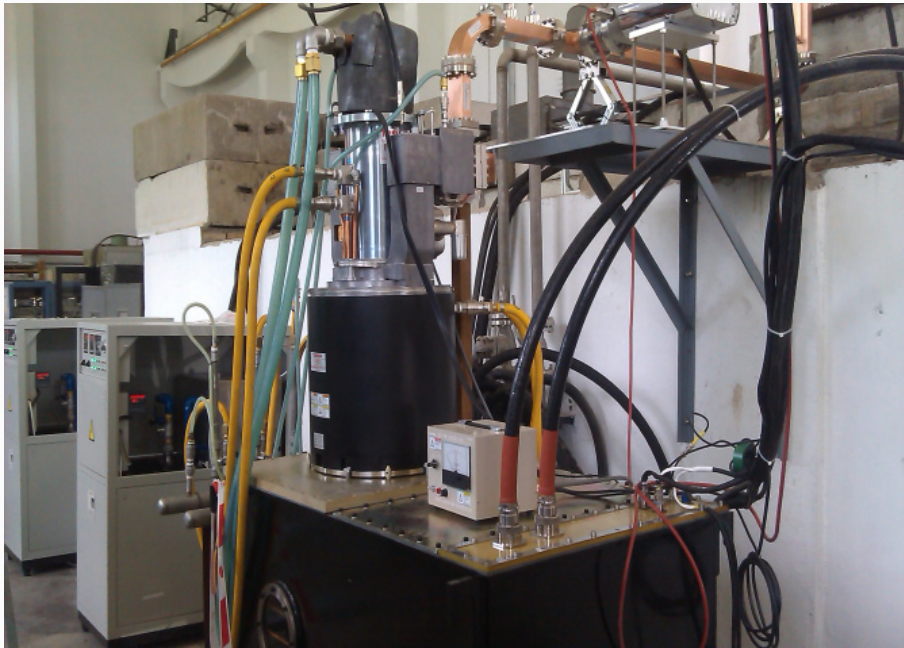

Klystron @ Test stand

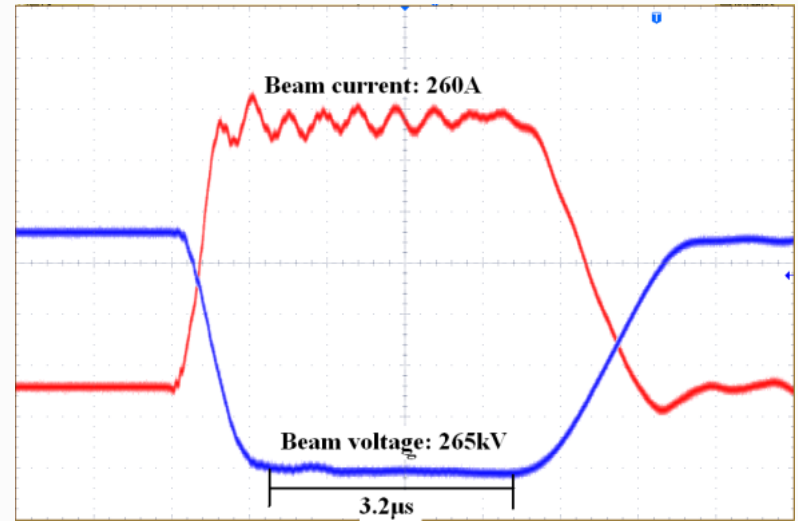

Klystron output @ 500Hz/27MW

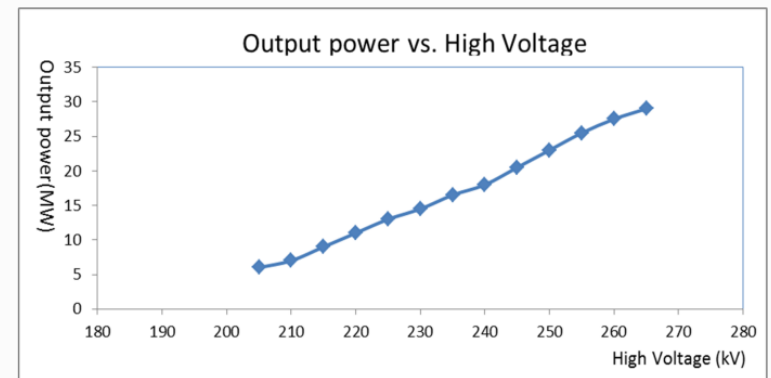

Klystron testing results

Pre-buncher and Buncher

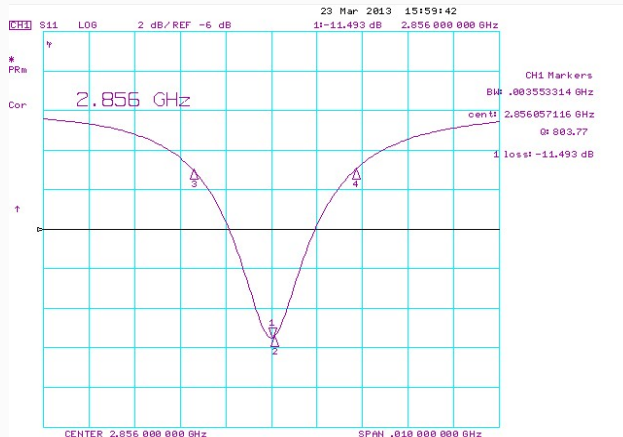
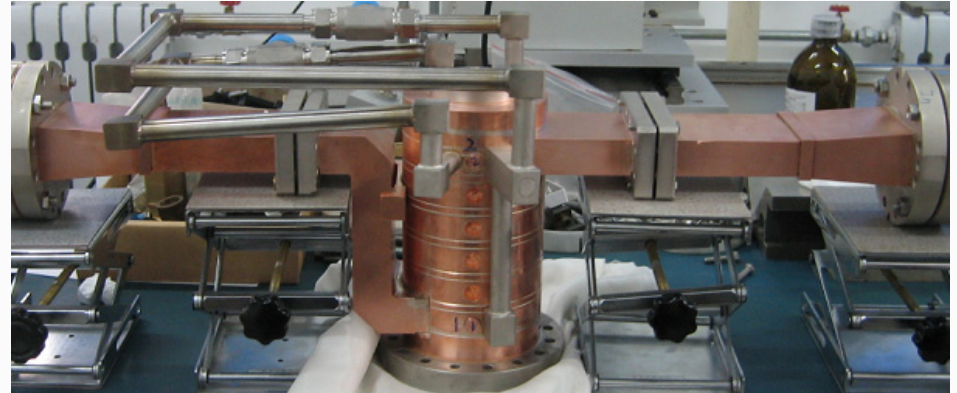
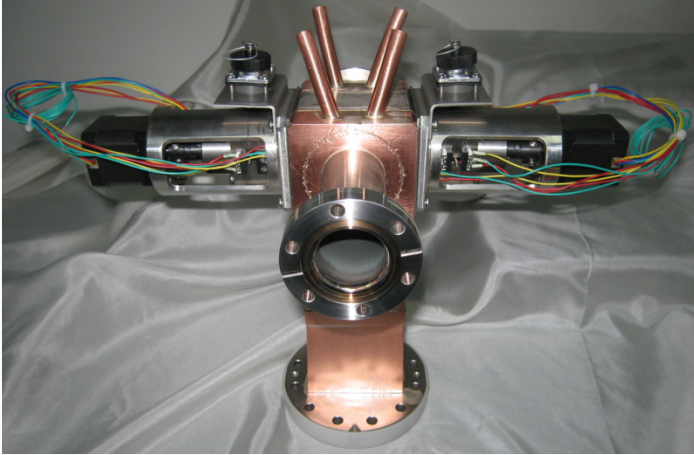

$f=2856 \pm 3.2\text{MHz}$
 $\beta \sim 1.73$
 $Q_0 \sim 2200$

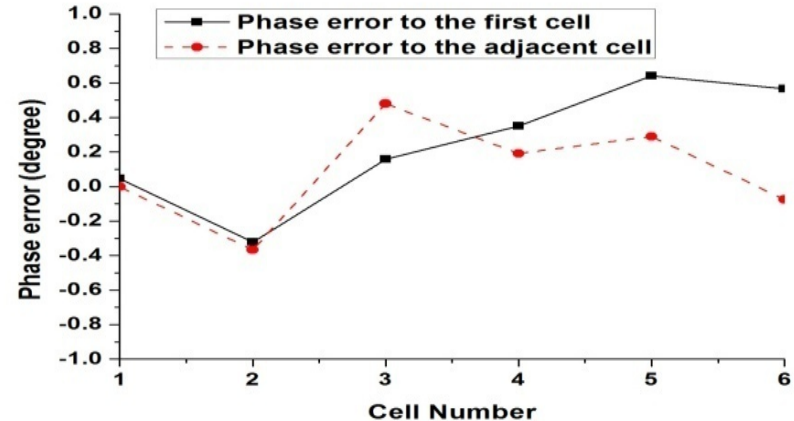

$VSWR @2856\text{MHz} \sim 1.02$
 $BW (VSWR < 1.20) \sim 5.5 \text{ MHz}$
 Attenuation factor $\sim 0.56 \text{ dB}$
 Filling time $\sim 50\text{ns}$

Accelerating Structure Design

- ③ To suppress the BBU (both regenerative and cumulative) effect, $\sim 1.3\text{m}$ long $2\pi/3$ mode quasi-constant gradient structure was adopted. The disk hole diameter decreases from 27.887mm to 23.726mm in a stepwise fashion along the structure (26.220mm to 19.093mm for BEPCII 3m long structure).
- ③ To detune the dipole mode, dipole mode frequency spread was increased by increasing the disk hole diameter step to $\sim 0.122\text{mm}$ ($\sim 0.085\text{mm}$ for the BEPCII 3m long structure).
- ③ 4 holes will be drilled at the 3rd to 6th disk of each structure. The HEM11 mode frequency will be increased to certain amount in these cells.

	NSC-KIPT	BEPCII	
Operation frequency	2856	2856	MHz
Operation temperature	40.0 ± 0.1	45.0 ± 0.1	$^{\circ}\text{C}$
Number of cells	34 regular cells/2 coupler cells	84 regular cells/2 coupler cells	
Section length	1338 (36 cells)	3050 (87 cells)	mm
Phase advance per cell	$2\pi/3$ - mode	$2\pi/3$ - mode	
Cell length	34.989783	34.989783	mm
Disk thickness (t)	5.84	5.84	mm
Iris diameter (2a)	27.887 - 23.726	26.220-19.093	mm
Cavity diameter (2b)	83.968 - 82.776	83.458-81.762	mm
Shunt impedance (r_0)	51.514 - 57.052	53.708-63.294	$\text{M}\Omega/\text{m}$
Q factor	13806 - 13753	13783-13711	
Group velocity (v_g/c)	0.02473 - 0.01415	0.02004-0.0063	
Filling time	215	823	ns
Attenuation parameter	0.1406	0.5383	Neper

Accelerating Structure

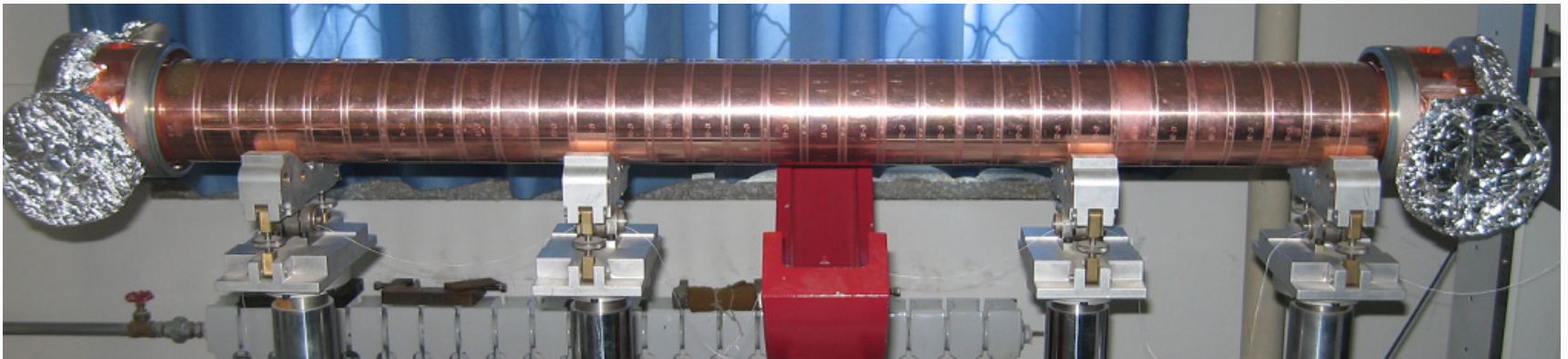
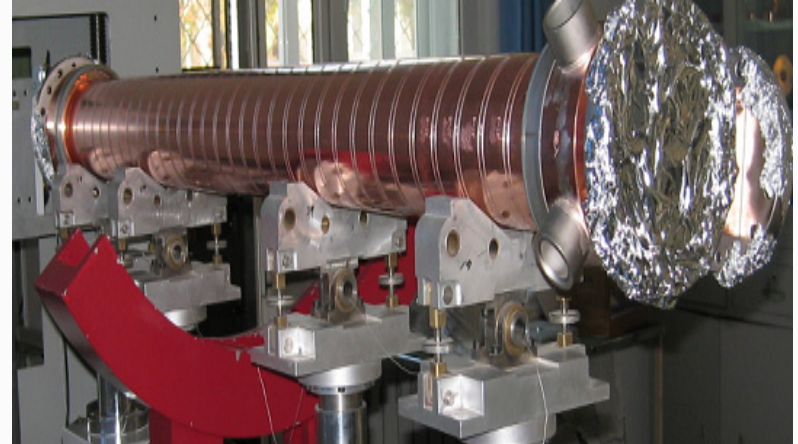
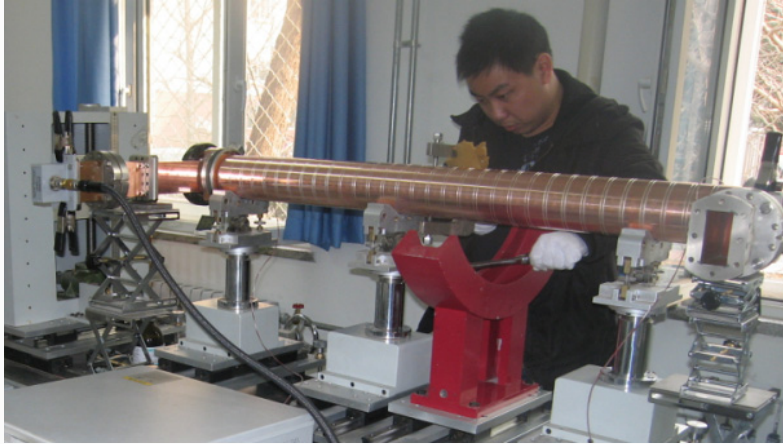

Measurement

VSWR @2856MHz= \sim 1.09
BW (VSWR<1.20) = \sim 5.2 MHz
Attenuation factor= \sim 1.38 dB
Filling time= \sim 222.4 ns

Simulation

VSWR @2856MHz= \sim 1.03
BW (VSWR<1.20) = \sim 5.4MHz
Attenuation factor= \sim 1.30dB
Filling time= \sim 215 ns

Beam Instrumentation

- ④ 8 button type BPMs and BLMs to measure the beam orbit and beam losses.
- ④ 3 PRs and 2 WSs to measure the beam profile.
- ④ 5 FCTs instead of BCTs and ACCTs to measure the beam current and pulse shape.
- ④ Two beam energy analyzing stations located at the exits of the injector and the Linac.
 - ④ The Strip Lame Screen (SLS, developed by KIPT) is used to measure the beam profile downstream the dipole analysing magnet at relatively higher beam power, by which the beam energy and energy spread can be determined.
- ④ Quadruple scanning method to measure the beam emittance and TWISS parameters at the linac exit.

BI Devices Distribution

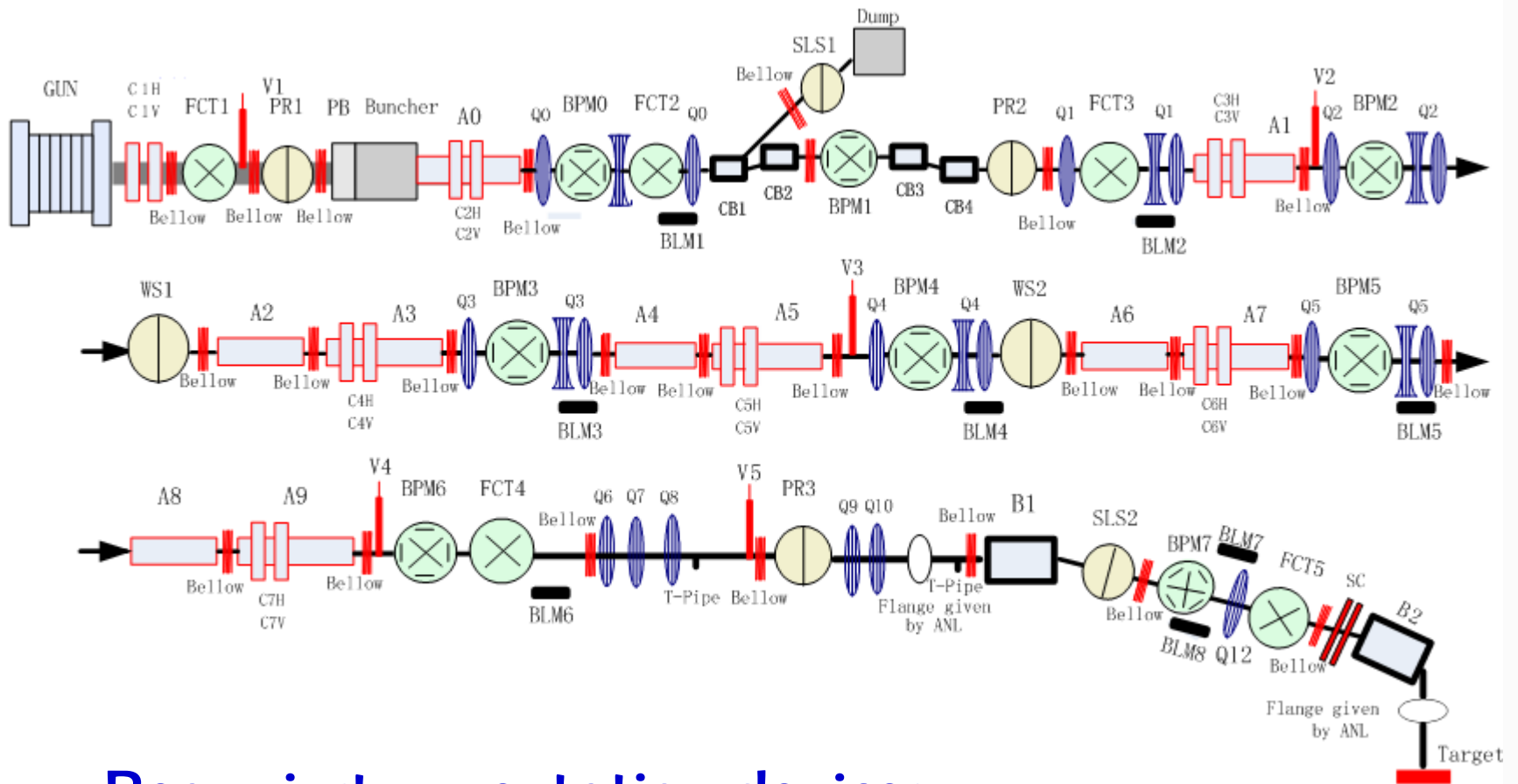

Beam instrumentation devices
distribution along the linac

BI Devices



Button type BPM

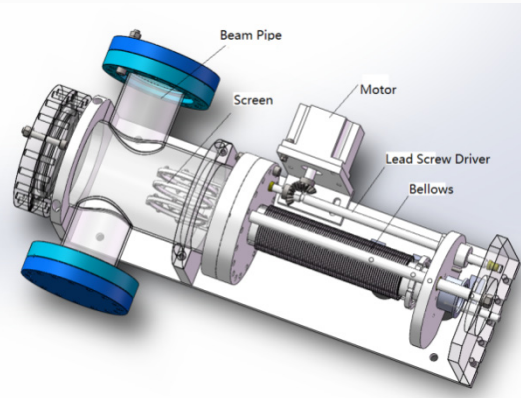

Strip lath assembly

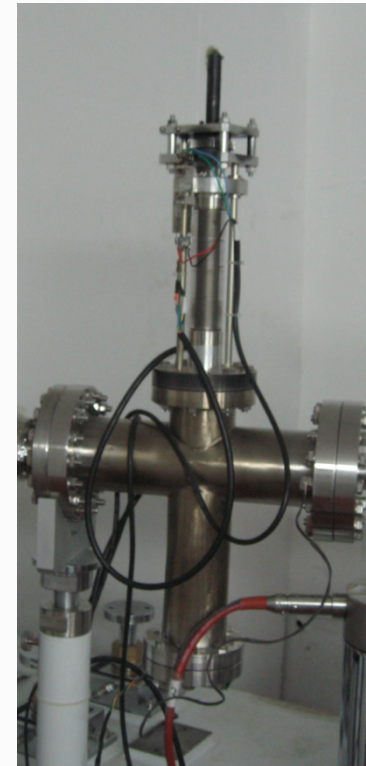

Beam Profile

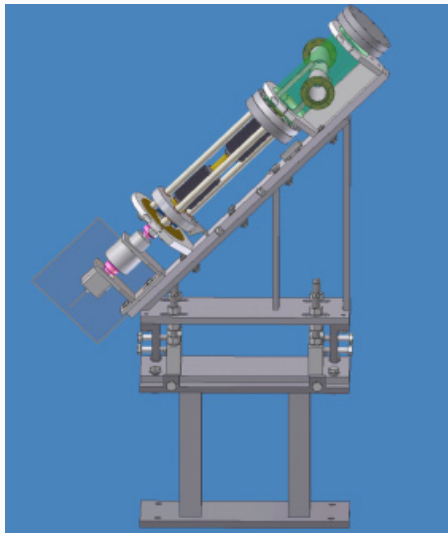

Wire scanner

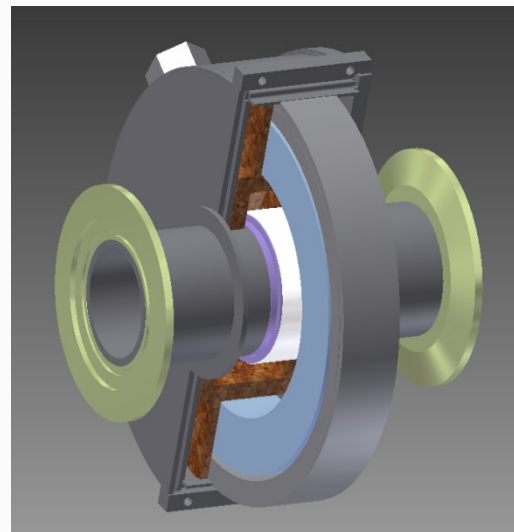

FCT

BI Electronics



Single pass librera for BPM



Strip lame assembly electronics and control unit

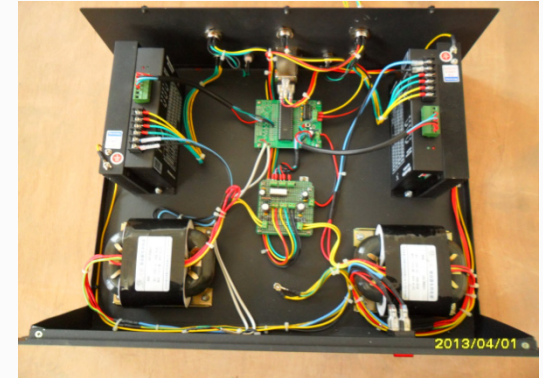

BLM electronics



PR electronics and control unit



Gated integrator of the WS and FCT

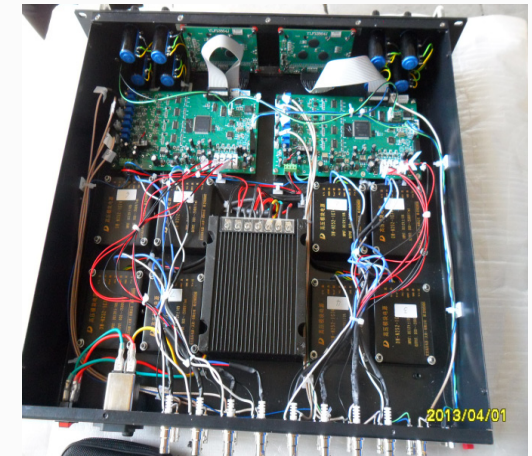

Magnets

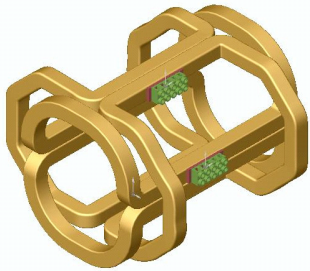

Saddle shape corrector

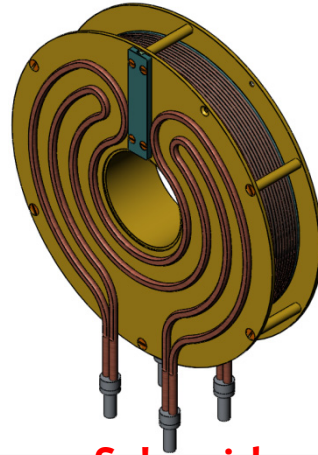

Solenoid



Triplet in field measurement

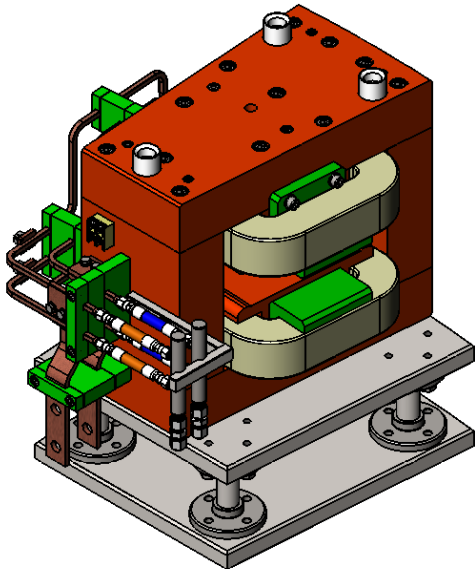

Chicane dipole CB1

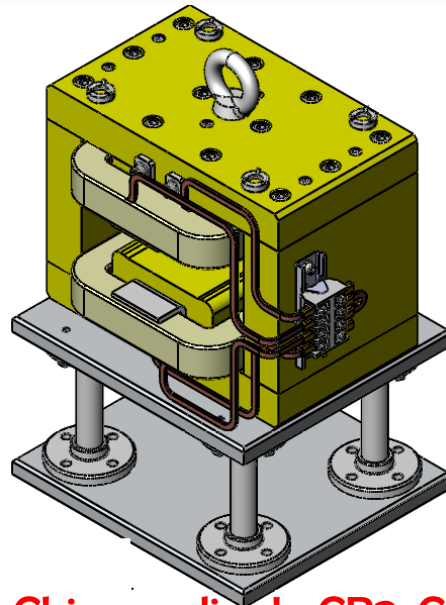

Chicane dipole CB2-CB3

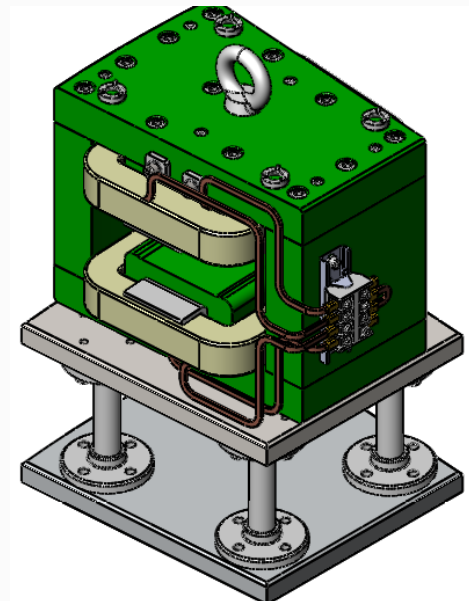

Chicane dipole CB4

Magnets



Transport line dipole

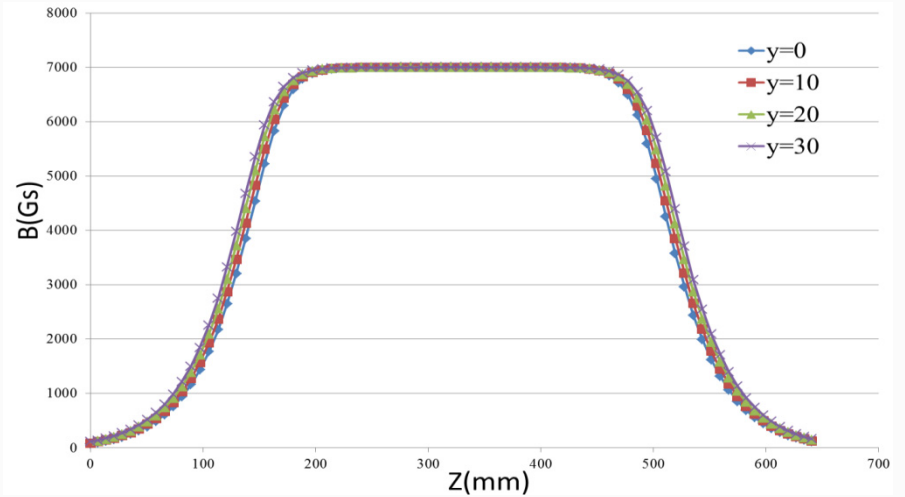

Transport line dipole field measurement

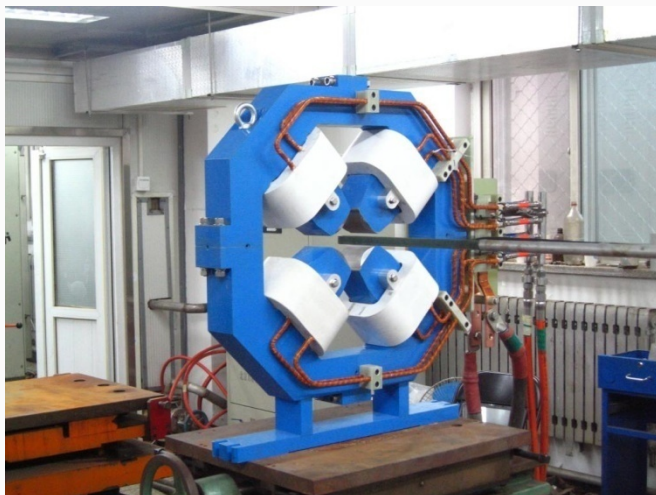

Transport line quadrupole

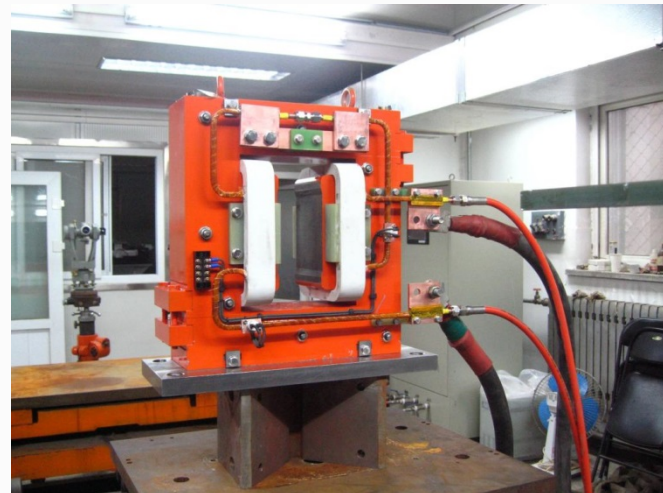

Scanning magnet

Vacuum System

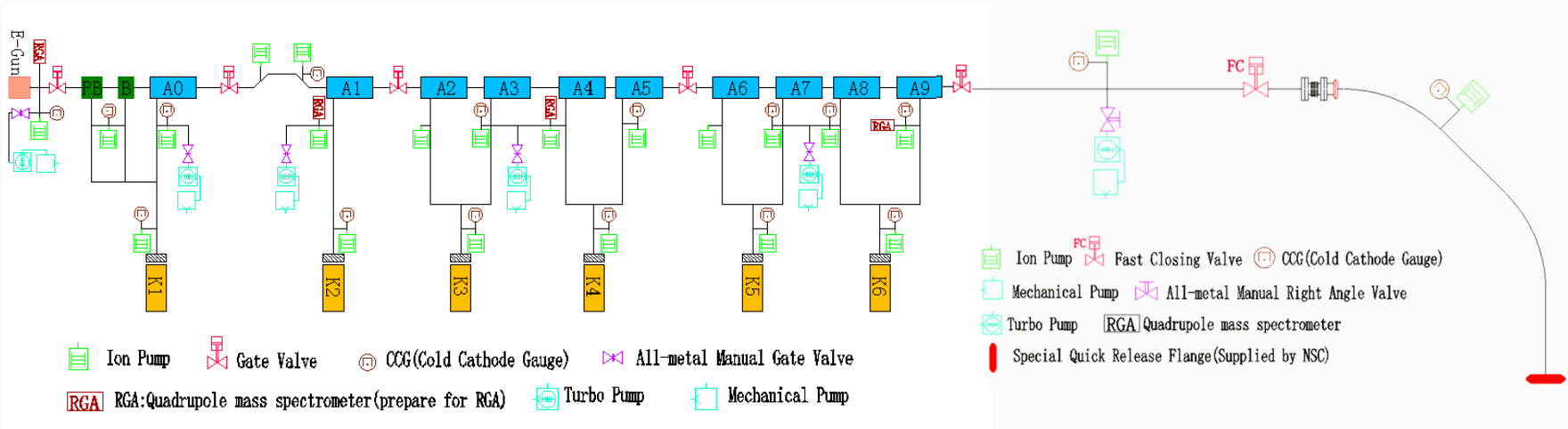

⑦ 7 sections by 6 gate valves.

⑦ The vacuum system assures the accelerator working at ultra high vacuum condition— 7.0×10^{-7} to 7.0×10^{-5} Pa.

⑦ Injector testing shows the vacuum system can meet the design requirement.

Vacuum System Devices



VAT manual angle valve (Switzerland)



Pfeiffer vacuum gauge (Germany)



VAT pneumatic gate valve (Switzerland)

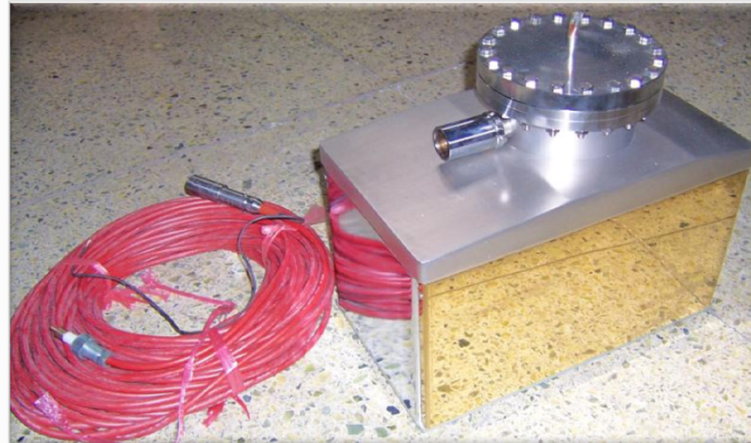

200L and 70L ion pump made in China (J)vac, Shanghai)



Vacuum System Devices



Ion pump testing system

LLRF System

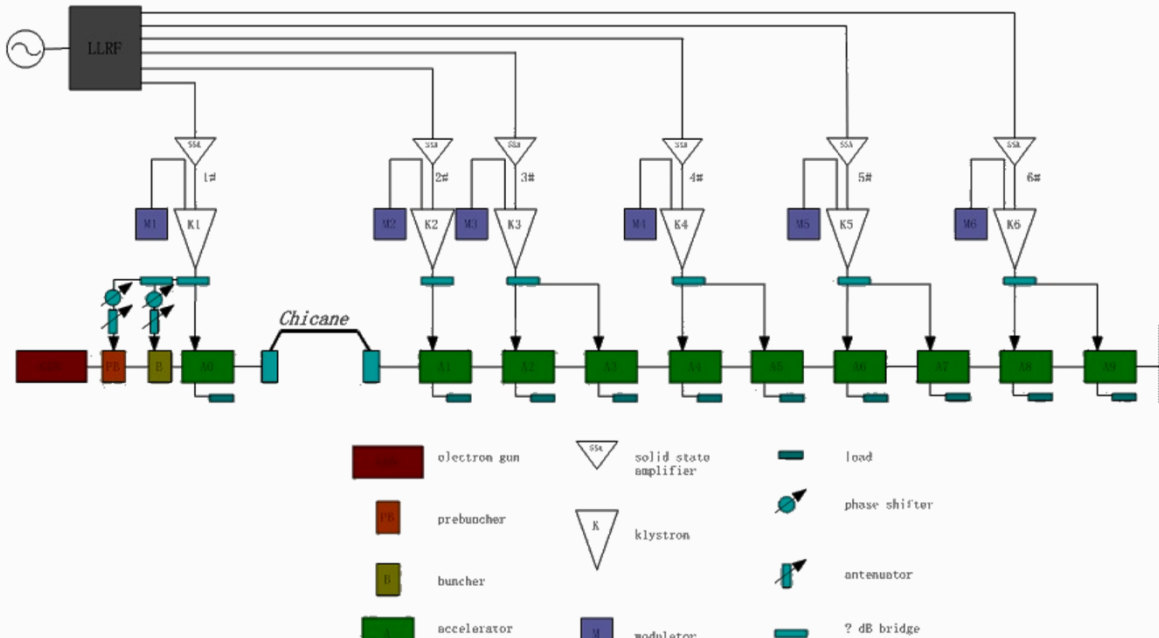

Control system diagram



One typical control unit

- @ Control and adjust RF field amplitude and phase
- @ Generate drive waveform for RF amplifier
- @ Beam loading compensation
- @ RF system monitoring and data analyzing

Control System

- @ EPICS based.
- @ Developed by CSS.
- @ Channel Access protocol.
- @ Online data storage and recovery realized by Channel Archiver.
- @ Most components have been tested in the injector testing facility.

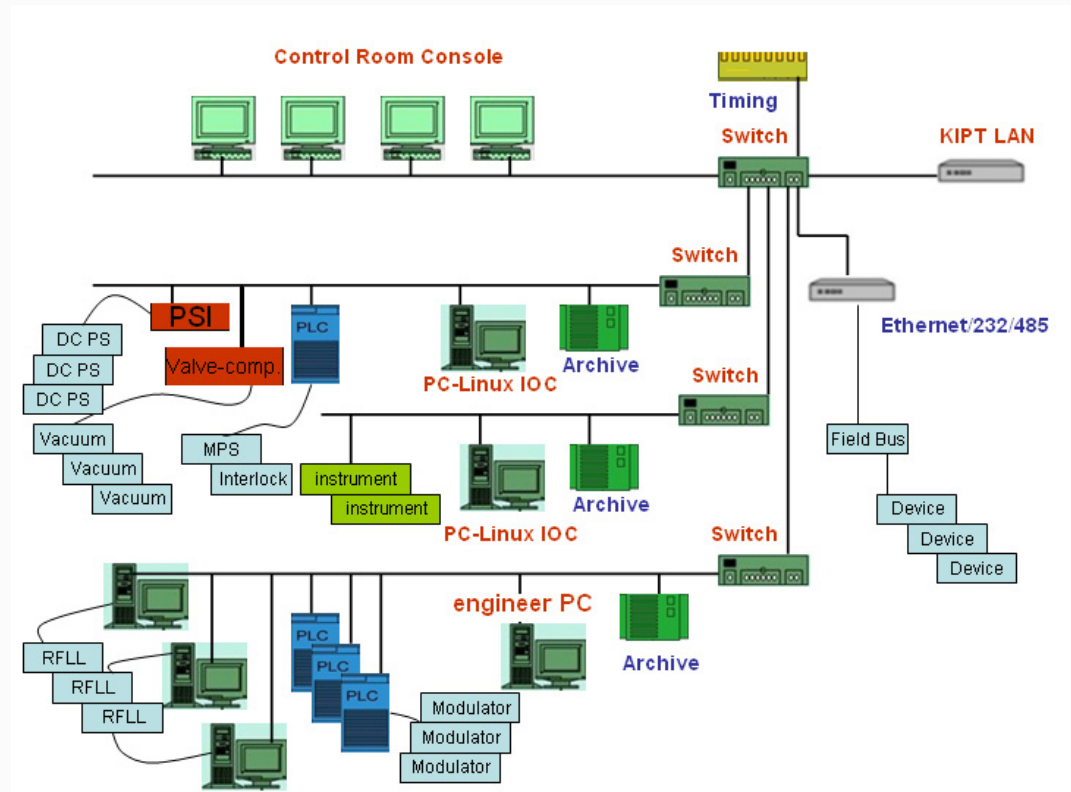

Summary

- ④ The construction of the 100MeV/100kW electron Linac by IHEP for the NSC KIPT neutron source is going on smoothly.
- ④ In 2012, the injector part of the Linac was pre-installed as a testing facility in the experimental hall #2 of IHEP. The testing results is satisfying.
- ④ The R&D of all the accelerator systems was completed in early March, 2013. Later, all the other auxiliary components are prepared and tested.
- ④ Recently, the injector testing facility was disassembled and all of the components for the whole Linac have been shipped to KIPT.
- ④ In early June, the machine will be assembled in KIPT by IHEP team collaborated with KIPT team, The water cooling system will be the 1st sub-system installed in the KIPT Linac, hopefully the accelerator conditioning and commissioning will be started soon.

Thanks for your attention !