

# LCLS-II ACCELERATOR CONTROL SYSTEM STATUS\*

D. Rogind, S. Kwon

SLAC National Accelerator Laboratory, Menlo Park, USA

## Abstract

The Linac Coherent Light Source complex at the SLAC National Accelerator Laboratory has been upgraded to add a new superconducting (SC) accelerator with beam rates up to 1 MHz. Though the majority of the more than twenty accelerator control systems are based on LCLS designs, to accommodate the increase in repetition rate from 120 Hz to 1 MHz, many of the diagnostics and global control systems were upgraded to high performance platforms with standalone CPUs running linuxRT to host the EPICS based controls. With installation and checkouts for control systems completing in 2022, the phased approach to integration and commissioning recently completed with demonstration of the threshold key performance parameters and first light occurring in the Summer of 2023. This paper provides an overview of the LCLS-II accelerator control system architecture, upgrades, the multi-year installation, checkout, integration, commissioning, and lessons learned.

## LCLS-II OVERVIEW

After close to a decade of work, the newly upgraded Linac Coherent Light Source (LCLS) X-ray free-electron laser (XFEL) at the Department of Energy's SLAC National Accelerator Laboratory (cartoon shown in Fig. 1) successfully produced its first X-rays this past summer of 2023. The brighter, more rapid bursts of X-rays will allow scientists to tackle challenges such as understanding how to adapt natural solutions for harvesting solar energy for a new generation of clean fuels, inventing sustainable manufacturing methods for industry, and designing a new generation of drugs based on the ability to create molecular movies of how our bodies respond to disease. LCLS-II delivers X-ray laser beams that are 10,000 times brighter than its predecessor [1]. Refer to Fig. 2, which graphs the

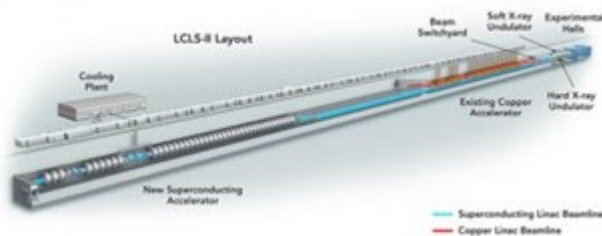

Figure 1: LCLS-II layout.

calculated spectral brightness from LCLS-II soft X-ray undulator (SXU) and hard X-ray undulator (HXU) at 4 GeV and high-repetition-rate operation.

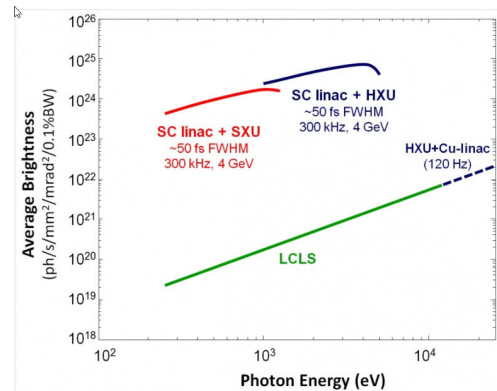

Figure 2: Calculated spectral brightness.

Staff from four national laboratories – Argonne, Berkeley Lab, Fermilab, and Jefferson Lab – along with Cornell University, worked together to build the facility's next-generation components. LCLS-II increases beam rate from LCLS-I's 120 pulses per second to 1 million pulses per second. The newly constructed dual cryogenics cooling plant supplies helium to the 37 cryomodules at a temperature of two Kelvin. New variable gap Hard X-Ray undulators (HXU) and Soft X-Ray (SXU) undulators can each receive beam from either the normal conducting (NC) LCLS-I or the SC LCLS-II, in parallel. The series of undulator magnets force electrons to give off energy in the form of X-rays. These X-rays are then delivered to a suite of experimental instruments for users to conduct experiments.

## KEY FEATURES OF LCLS-II

The new 4 GeV SC linear accelerator (linac), shown in Figure 3: Linac Coherent Light Source – II, occupies the first kilometer of the 3 km SLAC linac tunnel. The existing legacy copper facility was removed from the first kilometer, thus eliminating need for excavation. The normal conducting (NC) copper LCLS-I linac, which began operation in 2009, occupies the last third of the linac tunnel. The middle kilometer is occupied by the Facility for Advanced Accelerator Experimental Tests (FACET)-II.

## ACCELERATOR CONTROLS

LCLS-II Accelerator Control System Scope is comprised of the following systems:

- **Global Controls:** Timing, Network, Computing Infrastructure, Machine Protection (MPS), Racks & Cables, ATCA Common Platform
- **Diagnostics:** Beam Position Monitor (BPM), Beam Current Monitor (BCM), Bunch Length Monitor (BLM), General Motion (Wire Scanner, Collimator, Bunch Compressor), Undulator Control, Profile Monitor

\*Work supported by the U.S. Department of Energy under contract number DE-AC02-76SF00515

Content from this work may be used under the terms of the CC BY 4.0 licence (© 2023). Any distribution of this work must maintain attribution to the author(s), title of the work, publisher, and DOI



Figure 3: Linac Coherent Light Source – II.

- **Instrumentation & Control:** Vacuum, Cryomodule and Distribution Control, Temperature & Facilities Monitoring, Laser (UV and IR), Power Supply (DC and Pulsed)
- **Radio Frequency:** Low Level (LLRF) and High Power RF (HPRF)
- **Safety Systems:** Personnel Protection System (PPS), Beam Containment System (BCS), Oxygen Deficiency Monitor (ODM), Non-Ionizing Radiation Protection (NIRP)

Development of the LCLS-II accelerator controls systems necessitated solving a wide breadth of technical challenges to meet performance parameters. In addition, the large installation geography (spanning approximately 4 km, from the Injector in Sector 00 through E-Beam Dump) and the need for simultaneous operation with LCLS and FACET-II, required extensive planning and coordination to complete. Control system development included:

To accommodate the increase in repetition rate from 120 Hz to 1 MHz, many of the diagnostics and global control systems were upgraded to high performance ATCA based platforms, referred to as the ATCA Common Platform, with standalone CPUs running linuxRT to host the EPICS based controls. Every ATCA crate, of which 88 are deployed, contain at minimum electronics and busses for network, timing, and machine protection. Application specific electronics and firmware for the various diagnostics are housed in additional slots of the (up to 7 slot) ATCA crate. A diagram of the SLAC Common Platform is shown in Fig. 4.

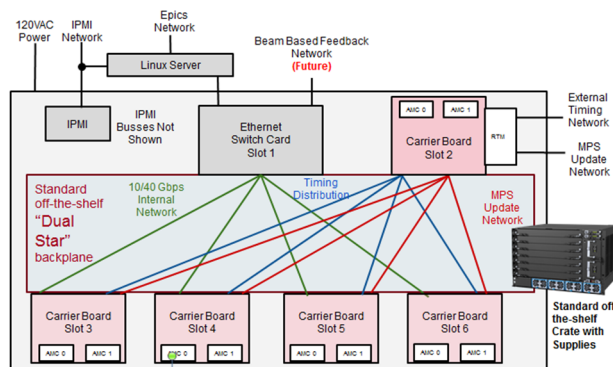

Figure 4: SLAC Common Platform Architecture.

The Timing and Phase Reference Line systems provide synchronized operation of beam control and diagnostic devices. The Phase Reference Line distributes a low jitter 1300 MHz reference from the injector laser at the front of the accelerator to the downstream most end of the SC linac’s RF cryomodule systems via a stabilized 1-3/4” rigid transmission line. Timing frames are distributed via a fiber optic transmission network across the entire 4 km length of the accelerator facility for timing clients listening along the many beam line destinations.

The Machine Protection System (MPS) provides a global interlock system designed to monitor the accelerator operating conditions and automatically reduce the overall beam power to prevent damage to sensitive accelerator components from radiation produced by the electron beam. The system deployed 88 link nodes across the entire 4 km SLAC linear accelerator complex and are used to collect

data from timing, diagnostic devices, beam lost monitors, temperature, and vacuum valves. A collection of central processors work in tandem to compute the overall state of the machine, feedback to the timing system, and issue permits for acceptable beam operations.

New Beam Position Monitors (BPM), capable of supporting MHz beam rates, were deployed from the LCLS-II gun through the Soft X-Ray Beam Dump. Compatibility upgrades to existing BPM systems were also completed in the Beam Switch Yard through the Hard X-Ray Dump. In total, approximately 270 BPMs, including Cold Button BPMs in the cryomodules, Cavity BPMs in the Undulator beamlines, and Stripline BPMs in other areas, were deployed or upgraded.

The Profile Monitor system provides an electron beam diagnostic used to measure the beam profile at 15 strategic locations utilizing insertable screens. Frame rates up to 120Hz and image sizes of 2 MB are accessible by operators and physicists for offline analysis and online beam tuning.

Cryogenic Distribution Controls System controls and monitors 37 Cryomodules, distribution boxes, and the equipment connecting them together. Approximately 1,500 RTDs, 100 pressure transducers, and 74 liquid level monitors are used as process inputs for 520 heaters and 84 cryogenic valves. Control loops and interlocks are integrated with the Cryoplant control system and allowing for seamless control of the entire cryogenic system in the cryogenic control room.

The LLRF system is composed of a distributed set of hardware and software for regulating the RF field in 280 L-band cavities and for controlling the natural frequency of the high Q superconducting RF (SRF) cavities. The primary function is to precisely measure RF fields in the SRF cavities, calculate and send corrective feedback signals to the SRF cavities, calculate the natural frequency of the SRF cavities and actuate tuners on the SRF cavities to keep them at the proper frequency. The system is deployed over 77 racks and 600 chassis to control RF field controllers, cavity tuners, power supplies and IOCs.

The Vacuum Controls System is responsible for instrumenting and controlling beamline ion pumps, gauges, valves, and pump carts for the Injector through the Electron Beam Dump. In addition to mechanical installation of the beamline equipment, the control system is deployed over 65 racks utilizing 18 programmable logic controllers (PLC) to process the large quantity of process signals. The system also isolates unexpected loss of vacuum by implementing valve interlocks which automatically close valves when pressure thresholds are exceeded.

The Temperature Monitor System instruments various accelerator components like waveguides, water flows, ambient air, Collimators, Chicanes, and magnets for diagnostic and interlocking purposes. Over 600 resistance temperature detectors (RTD) are deployed in 40 racks covering 30 Linac sectors.

The general motion system is used to control position and speed with precision readback for Bunch compressor chicanes (BC1B, BC2B), Collimators, and the Laser

Heater Undulator. In addition, complex control and detector read-back of 22 deployed high-speed Wire scanners are used to facilitate acquisition of wire position and beam loss signals required for diagnostic beam size measurements.

The Soft X-Ray Undulator (SXU) motion system provides control capabilities for 22 SXR undulator cells and the SXR Self Seeding station. Each cell is composed of a variable gap Undulator magnet, movable interspace, and phase shifter.

The Hard X-Ray Undulator (HXU) motion system provides control capabilities for 35 HXR undulator cells and the HXR Self Seeding station. Each cell is composed of a girder, mounted on cam movers, supporting a variable gap undulator magnet and phase shifter.

The Personnel Protection System (PPS) and the Beam Containment System (BCS) are components of the SLAC Radiation Safety System (RSS) used to protect personnel from radiation hazards. The LCLS-II upgrade increases the complexity and seriousness of potential beam generated hazards at SLAC and required the expansion of safety systems capabilities and physical footprint.

The BCS system prevents dangerous levels of radiation outside of the shielding enclosure. It monitors beam loss, limits beam power, and turns off the beam if allowable radiation levels are exceeded. New technical development of a credited safety RF cavity based Average Current Monitor (ACM), quartz-fiber based Long Beam Loss Monitors (LBLM), distributed Point Beam Loss Monitors (PBLM) and supporting electronics were required for to meet power detection criteria, microsecond response times and expanded physical areas of coverage.

The PPS system primary function is to keep persons away from radiation hazards using a combination of security, access controls and monitoring of radiation. A new PPS safety zone for the Linac West (sector 00-10) was created and existing zones for the Linac Middle, Global and Beam Switch Yard were modified to meet RSS requirements.

Non-radiation related hazards are also addressed by safety systems controls. The Oxygen Deficiency Monitor system is used to mitigate oxygen deficiency hazards associated with the use of cryogenics in the Superconducting Linac tunnel. Deployed in sector 00 through S07, the system utilizes oxygen sensors, ventilation, and visual/audio enunciators to monitor conditions and alarm for evacuation.

Lastly, a total of 901 DC Power Supply magnets and Pulsed Kicker magnets were instrumented to serve the LCLS-II beamlines.

## EPICS

### *Architecture*

A cartoon of the LCLS EPICS 3-tier control system architecture is shown in Fig. 5. The scalable LCLS controls computing infrastructure was expanded to accommodate the added devices and beamlines for LCLS-II.

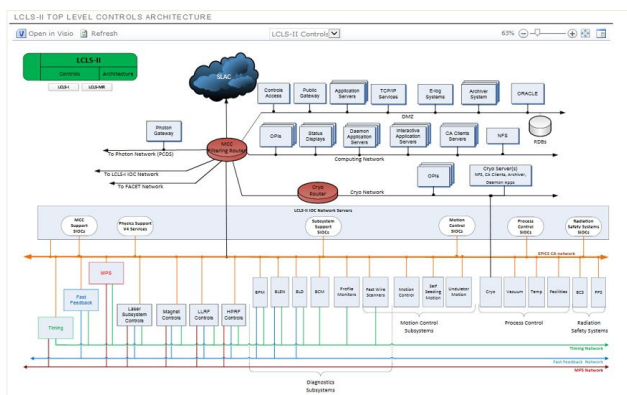

Figure 5: LCLS-II EPICS Control Systems.

Referring to Table 1, the collective NC and SC LCLS facility currently hosts 1274 EPICS IOCs serving up approximately 10 million Process Variables (PVs) of which approximately 800k are being archived.

At the onset of LCLS-II controls implementation, an effort was underway to upgrade from EPICS 3\* to EPICS 7\*. Currently 23 % of LCLS facility IOCs are EPICS3\* (mostly VME based IOCs supporting NC) while 77 % are EPICS7\*. Lastly, the soft IOCs hosted on RHEL servers comprise 29 % of the total IOC density, 45 % are hosted on industrial PCs in support of 1 MHz common platform-based controls, while 26 % of IOCs are hosted on VME based legacy systems.

Table 1: EPICS Metrics - LCLS Facility (SC and NC)

EPICS	Count	Version	Ratio	IOC OS	Ratio
IOCs	1274	EPICS 3*	23%	RHEL hosted	29%
PVs	10 M	EPICS 7*	77%	Linux RT	45%
Archived PVs	800k/1.2M			RTEMS	26%

### Additional Developments

Due to the heavy resource loading required by the project for many years, computing infrastructure upgrade projects did not receive high priority and thus the necessary staff to make progress. The following developments are either in progress or planned:

#### Computing Infrastructure

- Linux upgrade: RHEL6 -> RHEL7 -> RHEL9
- RTEMS upgrade
- Display Manager edm -> PyDM dynamic displays
- NFS V2 File System 8 Tb -> 24 Tb
- Preparation for NFS V4
- Network Switches 1 Gb -> 10 Gb
- Archive Appliance 600k PVs -> 1.2M PVs
- EPICS 7
- EPICS upgrade: EPICS3 -> EPICS7
- Channel Access CA -> PV Access PVA
- IOC rSrv -> qSrv
- All clients need to be PVA compliant
- TLS Cyber Security
- Orbit data through Beam Synchronous Acquisition Service (BSAS) for machine learning
- Beamline Data (BLD) via multicast network used by the experiments

### Development and Deployment Workflow

- Configuration management CVS & bare git repos -> GitHub enterprise
- Group accounts -> Individual logins
- Continuous Integration/ Continuous Deployment
- Compatibility with SLAC Shared Science Data Facility (S3DF)
- File system migration from AFS to SLAC Shared Science Data Facility (S3DF) and Kubernetes for applications, dockers, etc
- Web application roadmaps
- Higher performance front and back ends
- Oracle -> Postgres, MongoDB
- Oracle based APEX front end -> REACT Robot
- Remote monitoring

### INSTALLATION AND CHECKOUT

Installation required a large scale effort conducted over many years. Figure 6 shows all of the installation areas across the large installation geography, spanning approximately 4 km, from the Injector in Sector 00 through the E-Beam Dump and reaching to the Far Experimental Hall.

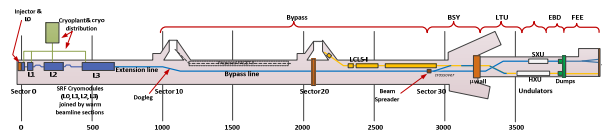

Figure 6: LCLS-II Areas.

The following noteworthy metrics highlight the magnitude of the installation:

- ~15 k cables, or 1.6 million linear feet, installed terminated and verified
- ~4 km of Network 10 Gb backbone and / or client connections
- ~4 km of warm and particle free vacuum
- 573 new & 106 existing racks wired, electronics loaded, powered
- 88 ATCA crates for 1 MHz controls & 144 CPU servers (hosting SC 1 MHz Timing, MPS with 1000's of inputs), ~300 diagnostics)
- ~4 km of dedicated fiber optic networks for each of SC Timing and MPS systems
- Cryomodule control system connects to 37 cryomodules and processes 1500 resistance temperature detectors, 100 pressure transducers, 74 liquid level monitors, 520 heaters, 84 cryogenic valves
- LLRF system controls 280 L-Band (1.3 GHz), 16 C-Band (3.9 GHz) cavity tuners, deployed with 77 racks and 600 chassis including RF field controllers, cavity tuners, and power supplies.
- 901 DC and Pulsed Power Supplies

### Installation and Checkout Sequencing

The multi-year installation required maintaining a detailed integrated schedule broken down per area and control system, linked with external dependencies (refer to

Fig. 7), resource loaded, and planned according to required access. Durations were calculated based on team size and work labor estimates.

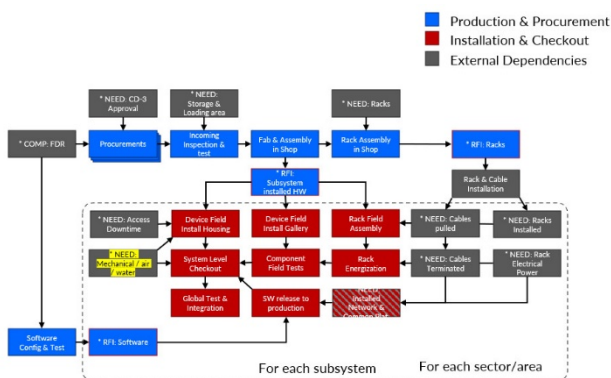

Figure 7: Control system installation sequence.

Successful pre-beam checkouts required parallel teams and activities. The approach for Controls teams was to complete as much checkout as possible to be ready when predecessors complete, as diagramed in Fig. 8.

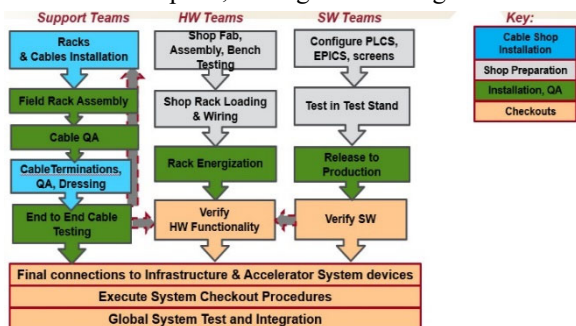

Figure 8: Parallel Checkout Activities.

### Installation Challenges

Installation hand-offs from other groups, such as cable plant, mechanical, vacuum, air, water, power, etc., tended to drive (/squeeze) the controls checkout schedule. Being last in the sequence to complete device and global system checkouts, controls were continuously under schedule pressure.

During all stages of installation, controls engineers coordinated closely with the cable shop to find and correct issues early. In the early stages of pulling cables, it became evident the cable plant design was not reviewed adequately in the first place, as evidenced by the required re-work. A multi-month effort immediately kicked off by lead engineers to QA and correct the entire cable plant. Later, a phone application was developed to track field cable pulling, termination, and QA status in real-time. It also became clear that smaller non-LCLS-II installation projects caused impact to the overall LCLS-II installation schedule; thus, external projects were included in the integrated schedule and the lab began prioritizing all projects. Shop work was also added to the schedule, as it affected installation. Installation Challenges are summarized in Table 2.

A large effort was required to choreograph installation work between all organizations corresponding to access, to

prioritize as necessary, track issues, dynamically adjust tasking, and to insert go no go decision points in order to keep NC accelerator areas operable post installation of new devices.

Table 2: Installation Challenges

Challenge	Mitigation
Running machines	Prioritize activities based on: <ul style="list-style-type: none"> <li>Needs of NC machines, SC Commissioning phases</li> <li>Access &amp; Resource availability</li> </ul>
Schedule Pressure	<ul style="list-style-type: none"> <li>Project must produce realistic schedules</li> <li>Controls leads must advocate for proper duration, incl. float</li> </ul>
Magnitude of Cable Plant	<ul style="list-style-type: none"> <li>Rigorous QA of cable plant design &amp; during installation</li> <li>Phone app was developed to track field cable pulling, termination, QA status in real-time</li> </ul>
Hand-offs drive predecessors	<ul style="list-style-type: none"> <li>Integrated schedule tracks external groups (mechanical, air, water, power, electrical, fabrication,...) and projects</li> <li>Include shop work</li> <li>Lab prioritized installation projects</li> <li>Weekly meetings with POCs, management; dashboards</li> </ul>

Weekly project installation meetings and integration meetings that included project staff and all organizational contributors, were held for years to status and track all activities. Dashboards (see example in Fig. 9) were created and updated weekly as a visual status and tracking tool for control system checkouts. Some issues needed tracking on a daily basis in order to come to a quick resolution.

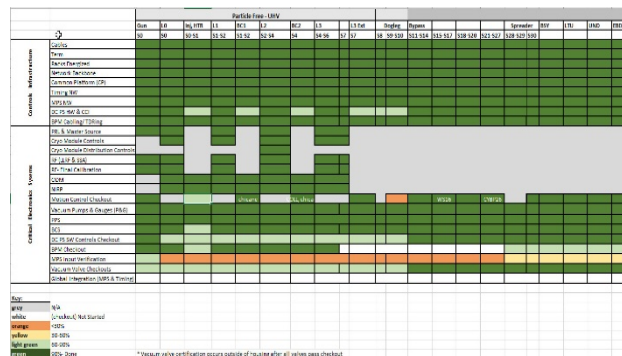

Figure 9: Example Control System Status Dashboard, circa 2022.

## COMMISSIONING

### Early Commissioning Opportunities

SLAC took advantage of a couple of key early commissioning opportunities to reduce both technical and schedule risk. The first was to commission the Injector source early, in 2018 [2]. This allowed us to gain experience with several new technologies including: a) Partner lab gun and buncher LLRF, b) particle free vacuum, and c) Common Platform ATCA based electronics, firmware and software that hosted initial control system configurations for SC Timing SC MPS, and fast diagnostics (i.e. BPMs).

Secondly, in 2020, the new Copper Linac To Soft X-Ray (CLTS) transfer beamline enabled early Soft X-Ray commissioning with NC (copper) beam. Along with undulator motion, this provided further opportunity to test the backward compatible electronics required for Timing and MPS, along with conceptualizing a modular approach to switching between NC and SC modes.

Content from this work may be used under the terms of the CC BY 4.0 licence (© 2023). Any distribution of this work must maintain attribution to the author(s), title of the work, publisher, and DOI

## SC Commissioning



After completion of the earlier opportunities, SC Commissioning progressed in several phases as follows:

1. Cryoplant #1 and cryogenic distribution
  - Gas circulation
  - Cooldown to 4 K
  - Cooldown to 2 K
2. Injector Commissioning with upgrades
  - Re-establish Electron gun operation for SC linac commissioning.
  - 100 MeV injector plus diagnostics beamline
3. SC linac and transport beamlines (with beam destination to BSY dump).
4. Spreader system (kicker magnets kick beam to HXU and SXU).
5. SXR and HXR undulators with SC beams, including e-beam dumps.
6. X-Ray transport beamlines
7. Instruments

## Timeline Summary

The overall timeline for key installation and commissioning activities is shown in Table 3.

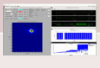
Table 3: Installation and Commissioning Timeline

Activity	Installation	Commissioning
LCLS-II Injector	2017-2018	2018
Long Downtime	2019	
NC Transport HXU	2019 	2020 
NC Transport to SXU (New Cu Line To Soft)	2019	2020
Cryogenics Plant, Distribution, Cryomodules	2019-2021 	2021-2022
SC Linac	2018-2021	2022
SC Transport to SXU		Summer 2023
SC Transport to HXU		Summer 2023
First Light		Summer 2023

## Commissioning Challenges

The largest scale technical challenges emerged during integration and commissioning with the Common Platform based [3] timing clients of the SC Timing system. A typical timing client is shown in Fig. 10 along with its connectivity to the EPICS Network, Operator stations and RHEL servers. Upon running electron beam and requesting to read beam synchronous acquisition (BSA) results or fault buffers into the EPICS layer, IOCs would crash. Data latency measured from the end of acquisition to fully transmit to EPICS Graphical User Interfaces (GUIs) took minutes.

During the first part of 2023, SLAC did not operate any accelerator programs (due to a safety shutdown and investigation after a tragic electrical accident), presenting a rare opportunity for the development team to utilize the production machine, with rate (no beam), to troubleshoot a myriad of issues. The team took the good part of the next 5 months utilizing the production machine to test and deploy firm-

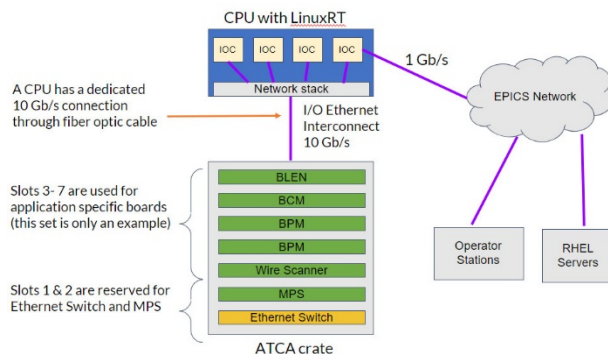

Figure 10: Common Platform Architecture.

ware and software improvements including:

- After QA of code, additional error handling.
- Addition of diagnostics and stress testing for root cause bug analysis.
- Utilizing jumbo frames from CPU to ATCA crate to reduce latency.
- Prioritization of threads for optimizing network stack throughput.
- Optimize BSA-related software code (API and device support) to reduce CPU load
- GUI modifications to request data at slower rates.

Additionally, the following recommendations were made:

- Upgrade the network interface between the CPU and the EPICS network to 10 Gb/sec.
- Implement common platform ATCA to CPU out of order protocol packets.
- Implement CPU core optimization.
- Upgrade the RHEL server memory.

Note: Early commissioning required all LinuxRT CPUs to upgrade RAM from 16 GB to 128 GB.

## LESSONS LEARNED

Several lessons were learned in many different areas:

### Schedule

- Off-project activities, including shop work, can become schedule drivers and must be managed together with the integrated project schedule
- All projects must be prioritized

### Cable Plant Design & Installation

- Rigorous quality assurance of cable plant design and installation
- Have efficiency tools ready ahead of time (cables, inventory, travellers, etc)
- Need for proven process to deliver cable plant. Use of modern 3D design and routing tools

### Technical

- Code QA & error handling
- Stress test complex systems opportunistically
- Incorporate automation, continuous integration / continuous deployment

### Strategic

- Maintain off-project, dedicated resources (within budget constraints) to keep up with upgrade plans for computing infrastructure and applications

## ROAD AHEAD

### LCLS-II High Energy (HE) Upgrade

The LCLS-II accelerator is in the design phase for its transformative High Energy (HE) upgrade. This project doubles accelerator electron energy from 4 GeV to 8 GeV and extends the X-ray energy range from 5 keV to 8 keV in order to achieve a unique hard x-ray source to enable the study of atomic-scale dynamics, deeper penetration into materials, and enhanced resolution [4]. This capability cannot be provided by any existing or planned light sources. Refer to Figs. 11 and 12.

The HE project installs:

- 23 additional cryomodules to increase the LCLS-II accelerator energy to 8 GeV
- New cryogenic distribution system between Cryoplant 2 and the new L4 linac
- Upgraded soft x-ray undulator for 8 GeV operation.

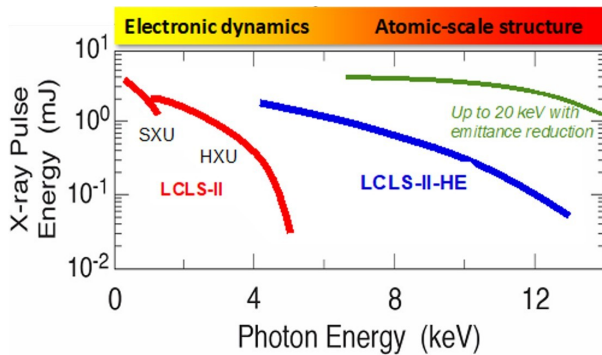

Figure 11: Performance of LCLS-II HE in comparison to other X-ray sources.

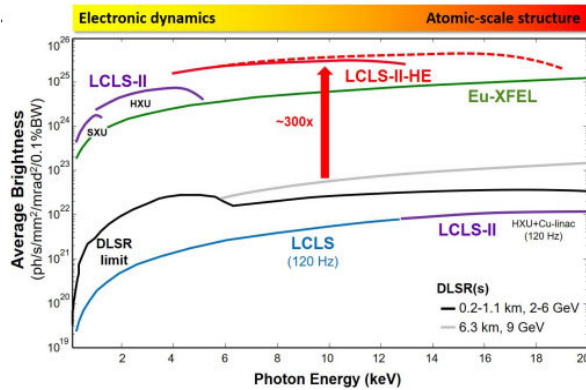

Figure 12: Average brightness of 300 times the capability of a diffraction-limited storage ring (DLSR).

## ACKNOWLEDGEMENTS

Special acknowledgement extends to the entire team of LCLS-II controls engineers (across multiple organizations), physicists and colleagues working on the construction, installation and commissioning of LCLS-II resulting in the achievement of first x-ray light in the Summer of 2023 [5]. Regrettably, individuals are too numerous to reference by name.

## REFERENCES

- [1] “LCLS-II Final Design Report”, SLAC, Menlo Park, USA, Rep. LCLSII-1.1-DR-0251-R0
- [2] D. Rogind *et al.*, “SLAC LCLS-II injector source controls and early injector commissioning”, in *Proc. 16th Int. Conf. on Accelerator and Large Experimental Control Systems (ICALPECS'17)*, Barcelona, Spain, Oct. 2017, pp. 1340-1343. doi:10.18429/JACoW-ICALPECS2017-THPHA002
- [3] J.C. Frisch *et al.*, “A FPGA Based common Platform for LCLS2 Beam Diagnostics and Controls”, in *Proc. Int. Beam Instrumentation Conf. (IBIC'16)*, Barcelona, Spain, Sep. 2016, pp. 650-653. doi:10.18429/JACoW-IBIC2016-WEPG15
- [4] <https://www.osti.gov/servlets/purl/1634206/>
- [5] <https://www6.slac.stanford.edu/news/2023-09-18-slac-fires-worlds-most-powerful-x-ray-laser-lcls-ii-ushers-new-era-science/>

Content from this work may be used under the terms of the CC BY 4.0 licence (© 2023). Any distribution of this work must maintain attribution to the author(s), title of the work, publisher, and DOI