

Rebuncher control loop

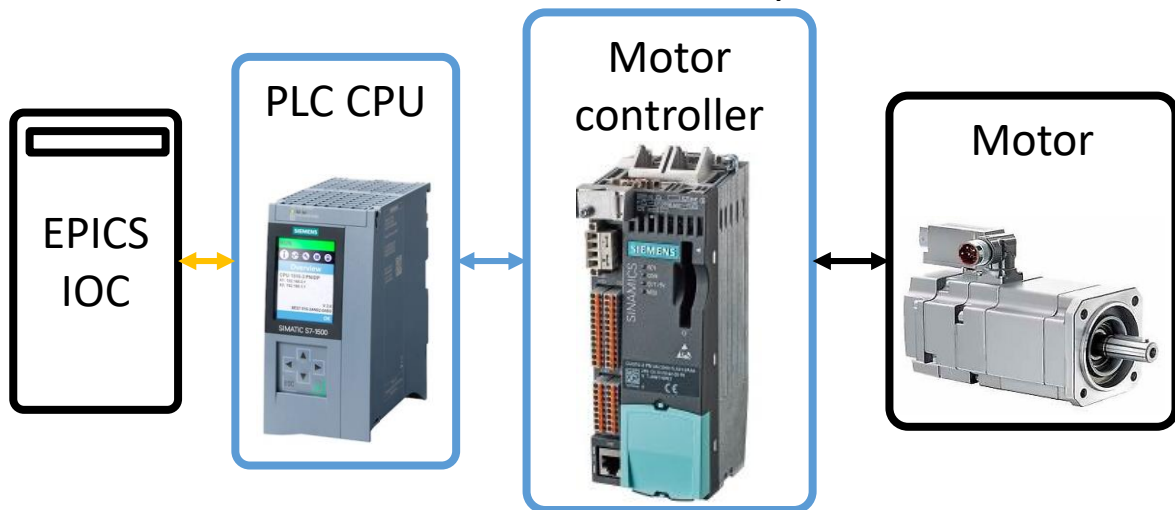

Cavity control loop (ET200SP)

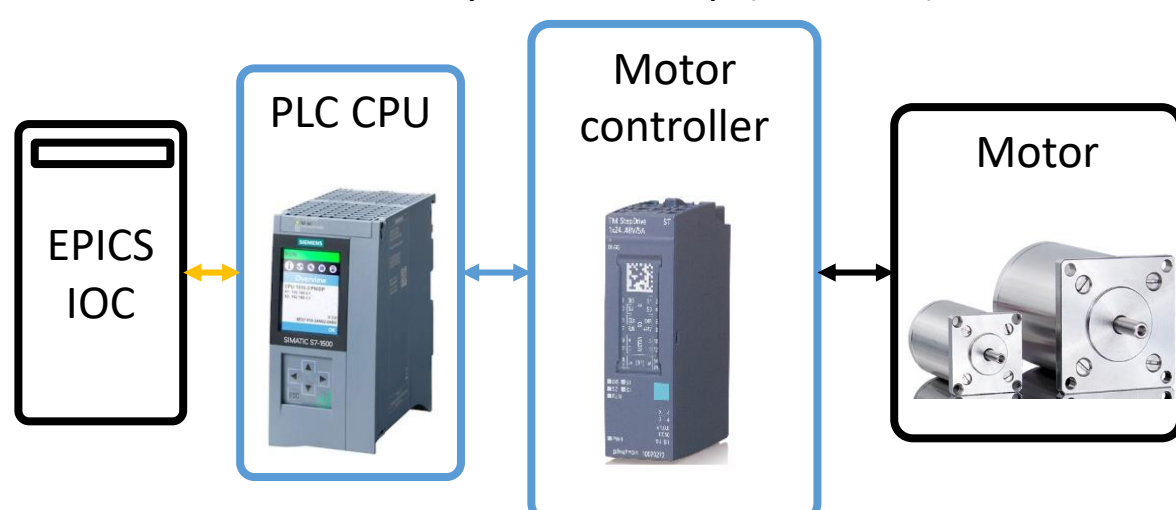

Cavity control loop (PhyMotion)

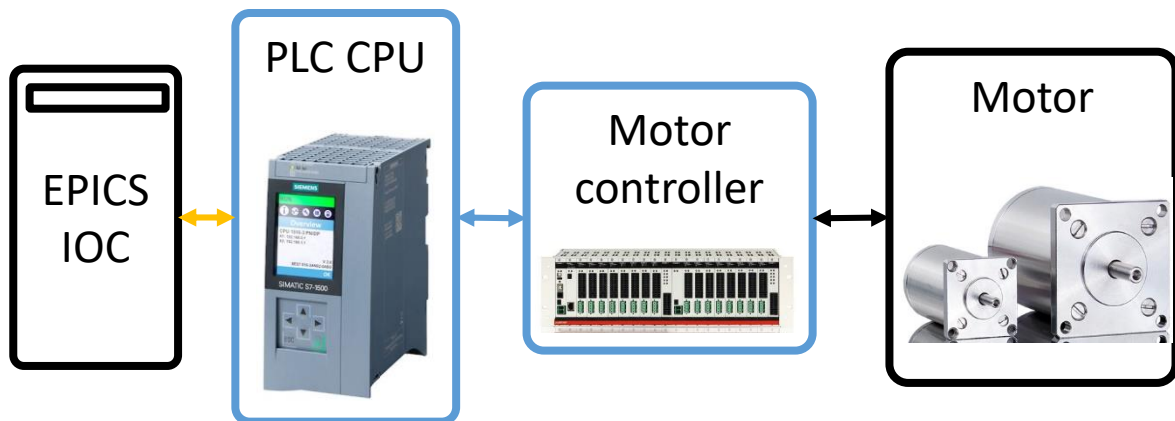

Tuning automatic process

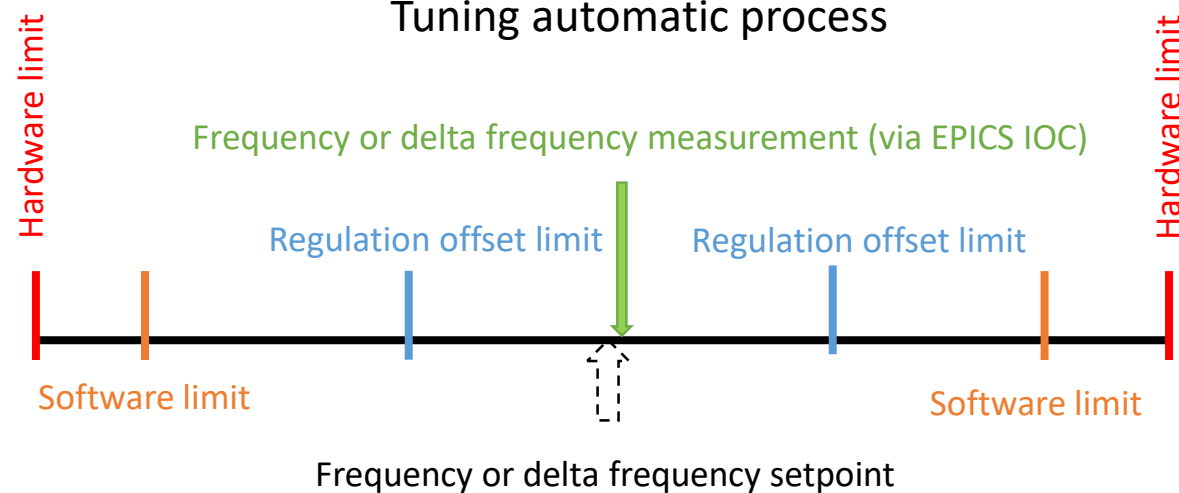

MOTORIZED REGULATION FOR THE SARAF PROJECT

T.Joannem[†], D.Darde[†], CEA Paris-Saclay IRFU DIS, Saclay, France
F.Gohier, F.Gougnaud, P.Guiho, A.Roger, N.Solenne, P.Lotrus CEA Paris-Saclay IRFU DIS, Saclay, France



Rebunchers control loop

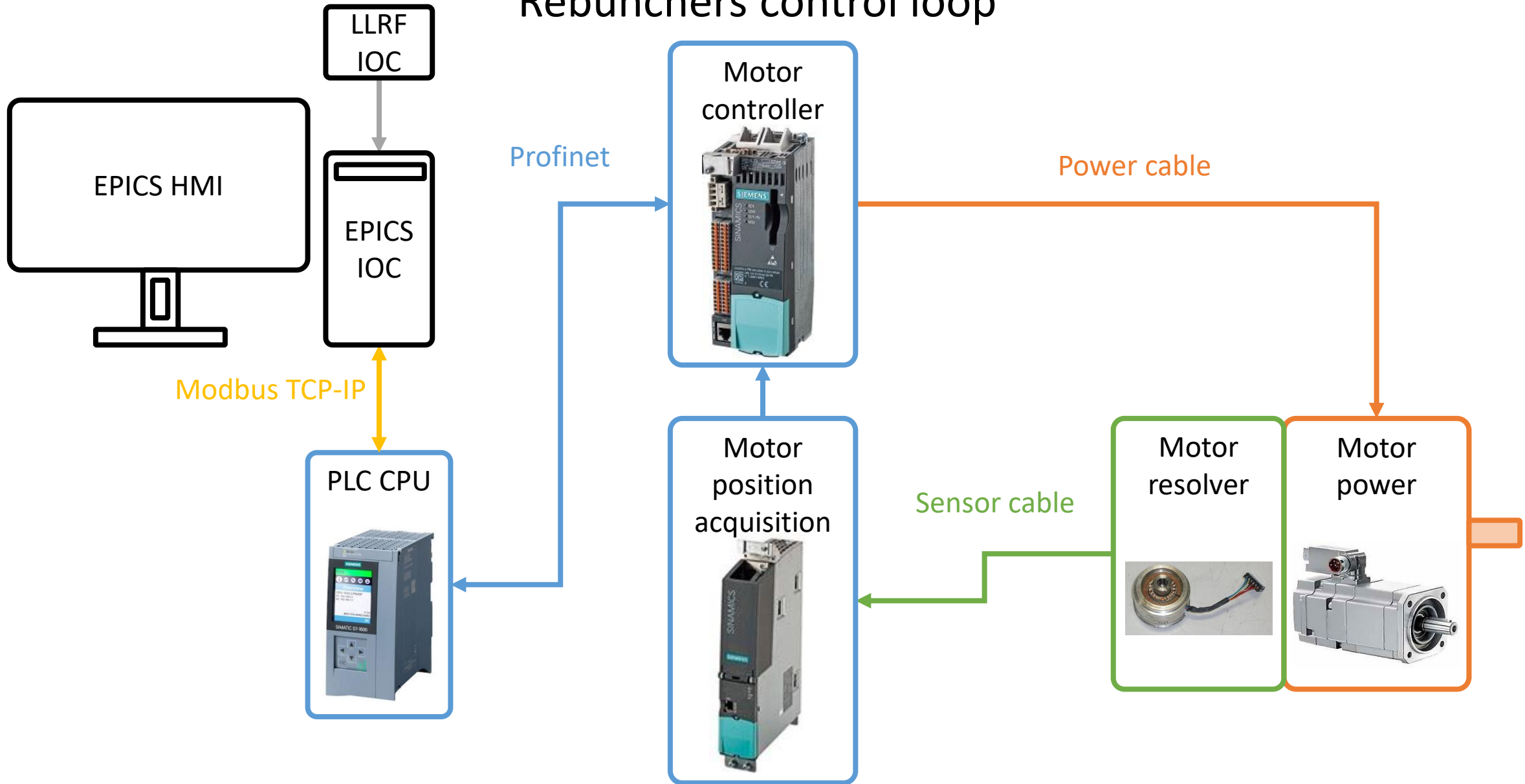

MOTORIZED REGULATION FOR THE SARAF PROJECT

T.Joannem[†], D.Darde[†], CEA Paris-Saclay IRFU DIS, Saclay, France
 F.Gohier, F.Gougnaud, P.Guiho, A.Roger, N.Solenne, P.Lotrus CEA Paris-Saclay IRFU DIS, Saclay, France



Cavity control loop (ET200SP)

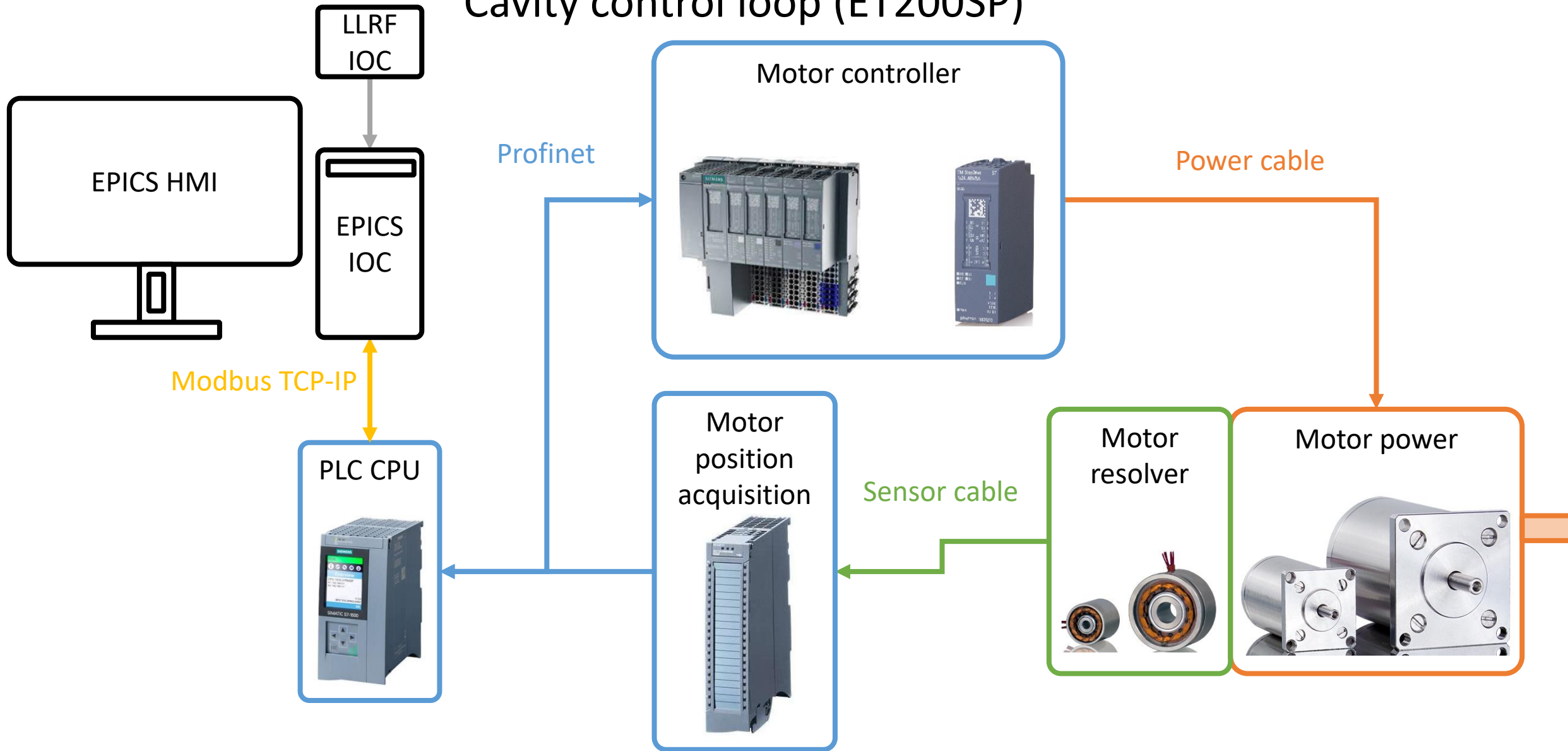

MOTORIZED REGULATION FOR THE SARAF PROJECT

T.Joannem[†], D.Darde[†], CEA Paris-Saclay IRFU DIS, Saclay, France
 F.Gohier, F.Gougnaud, P.Guiho, A.Roger, N.Solenne, P.Lotrus CEA Paris-Saclay IRFU DIS, Saclay, France



Cavity control loop (ET200SP)

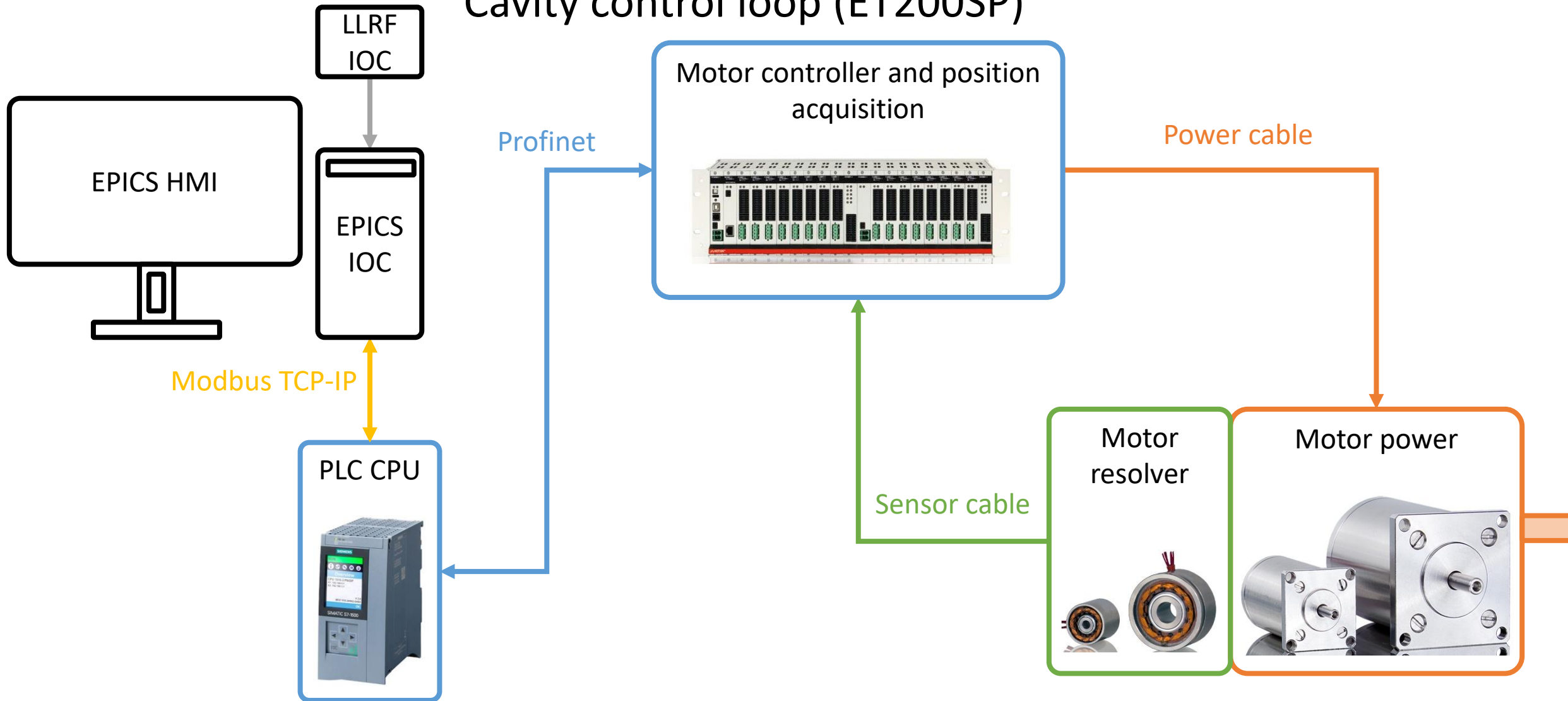

Tuning automatic process

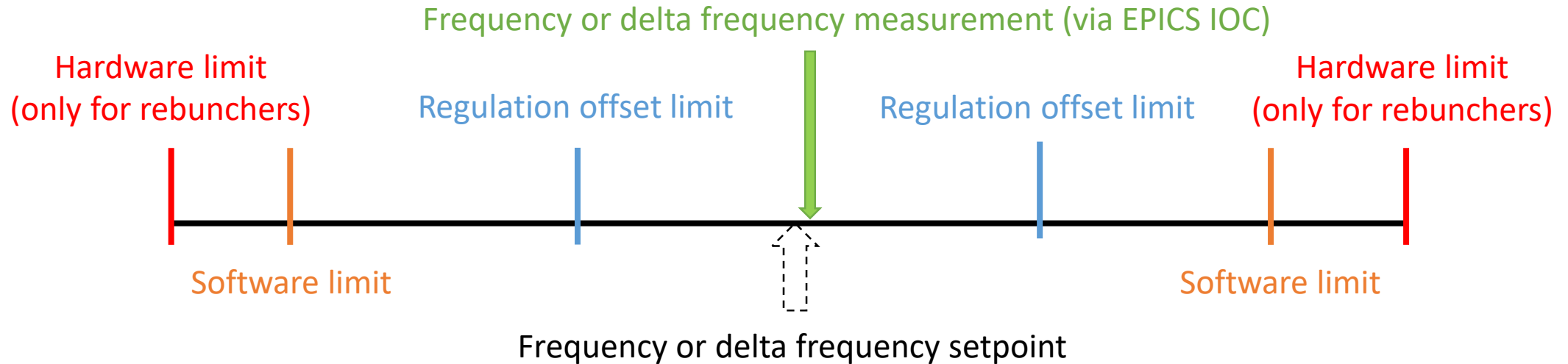

Goal

- Regulate frequency with a slow regulation loop
- Avoid frequency perturbations done by the regulation system

Frequency or delta frequency measurement

- Data provided by LLRF IOC
- Communication between LLRF IOC and tuning PLC IOC
- Data received as input from PLC point of view

Automatic process

1. If frequency measurement is outside of regulation offset limits
2. Motor is sent to estimated frequency setpoint by one movement
3. Stop motor when frequency setpoint is reach

Security

1. Software limits manage by PLC CPU
2. Hardware limits manage by motor controller