

THE FAULT DIAGNOSIS OF EVENT TIMING SYSTEM IN SuperKEKB*

D. Wang^{1,†}, K. Furukawa, M. Satoh, H. Kaji, H. Sugimura, KEK, Japan
Y. Iitsuka, East Japan Institute of Technology Co., Ltd, Japan
T. Kudou, S. Kusano, Mitsubishi Electric System & Service Co., Ltd, Japan
¹also at SOKENDAI, Japan

Abstract

The new MRF event timing system is one of the most important components to maintain the reliable and stable operation of the SuperKEKB project. This system is utilized to distribute high precision level timing signals and accompanying control instructions to synchronize different subsystems and machines. Event generator (EVG) generates signals of different beam modes every 50-Hz pulse which contains several event codes while Event receivers (EVR) receives them and output signals to dedicated devices all over the installation. To certain these events are consistent during the distribution, an event fault diagnosis system is essentially needed. An EVR based event timing diagnostic system is thus developed by modifying the driver support module to provide a log system of persistent event data as well as comparing the received event codes with the beam injector pattern, detecting the event timing interval fault and notifying the results by email every day. Then, we are able to locate the fault, analyze the data, fix bugs or replace hardware and resume accelerator operation quickly.

INTRODUCTION

The SuperKEKB is an electron/positron collider upgraded from the KEKB project since 2010 at KEK, whose scientific target is to update the world highest luminosity record and discover new particle physics by Belle II experiment. The 7 GeV electrons and 4 GeV positrons are injected into different main rings (MRs) called high energy ring (HER) and low energy ring (LER), respectively. During the phase-2 operation in 2018, a newly constructed 1.1 GeV Damping Ring (DR) at the middle of injector linac (LINAC) aiming to lower the positron emittance was deployed. One of the major challenges in the phase-3 operation is the upgrade of timing system of SuperKEKB [1]. The 700-meter LINAC delivers trigger signals to five rings, SuperKEKB HER/LER, two light source ring PF and PF-AR and a positron DR. The DR timing signal must synchronize with the MR signal.

For switching the beam modes swiftly, a large quantities data like bucket selection delay time, beam mode event codes and pulse number is required to update rapidly. Two sets of timing signals should be conveyed because the condition of beam line before DR and after DR is dissimilar. Therefore we make use of three EVGs and some other modules to construct our timing delivery system. With the growth of the system complexity, it is important to diagnose the timing system and ensure the correctness of the signal delivery.

Hence a fault diagnosis system is developed to assist us to monitor the timing event information.

In this paper, some efforts to improve the reliability and stability of timing system will be introduced.

TIMING SYSTEM ARCHITECTURE

At an accelerator facility, the function of timing system is to provide synchronized trigger signal to all relevant components and devices which locates at LINAC, beam transmission line, injection and extraction system and beam monitor system. The precision of synchronization depends on the operation requirement as well as the size of the installation [2]. In our case, a jitter of less than 30 ps is required in SuperKEKB MR and 300/700 ps in PF/PF-AR.

MRF Event Timing

We introduced the event timing system produced by the MRF company to meet our requirements [3]. The products we choose for our main timing system are “Event Generator (VME-EVG-230)” and “Event Receiver (VME-EVR-230-RF)”. At SuperKEKB, the event clock rate is 114.24 MHz and hence the minimal event code interval is around 9 nanosecond. Every 20 ms, depending on the beam mode, 11 or 12 events are generated and distributed to more than 60 EVRs all over the SuperKEKB.

The EVG uses optical fiber to transmit a 16-bit word by 8b/10b encoding. Inside this 16-bit word, 8-bit distributed bus running in parallel and independent of the other 8-bit allows distribution of timing signals updated with the event clock rate. Almost all 256 event codes except for some special functions can be defined by users. The EVG distributes signal by fanout Units to an array of EVRs. Each EVR is able to generate pulse with an associated delay and width to devices. It must be emphasized that the MRF timing system is well integrated with EPICS system with the help of mr-fioc2 device support module [4]. Figure 1 is the scheme of the MRF timing system.

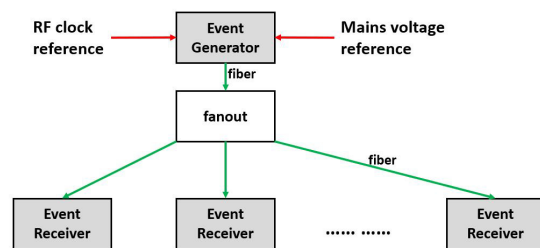

Figure 1: The MRF event system.

* Work supported China Scholarship Council

† sdcswd@post.kek.jp

Content from this work may be used under the terms of the CC BY 3.0 licence (© 2019). Any distribution of this work must maintain attribution to the author(s), title of the work, publisher, and DOI.

The EVR decodes the optical signal and writes the event code into a 32-bit wide FIFO memory with attached timestamp information. This FIFO memory can hold up to 512 events and timestamps and each pair consists of an 8-bit event code and a 24-bit timestamp register value. The operation of an event writing to FIFO will trigger a VME interrupt request.

The hardware sequencer RAM is a vital units in EVG which provides a method of transmitting or playing back sequences of events with defined delay time. The users are allowed to change the event codes, delay timestamp and sequencer trigger source but these changes are only temporarily saved in the software sequencer. When users are satisfied with the changes then they can use 'commit' action to update the changes to the hardware sequencer [5].

Pulse to Pulse Modulation

The SuperKEKB LINAC is operated via event-based, global, and synchronized controls to inject beams with different parameters into four separate storage rings simultaneously. One of the crucial technologies used during the operation is Pulse-to-Pulse Modulation (PPM) [6]. A single LINAC would behave as four independent virtual accelerators with hundreds of independent parameters modulated pulse-by-pulse at 50 Hz (Fig. 2).

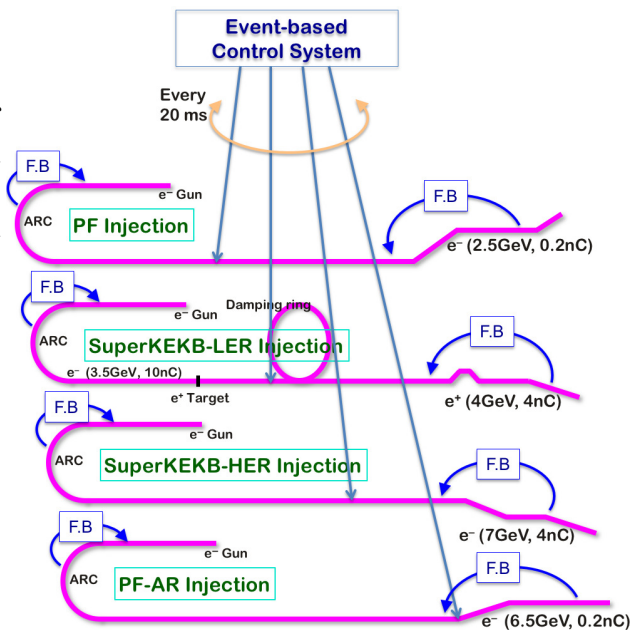

Figure 2: A single linac behaves as four virtual accelerators to inject their beams into four separate storage rings.

Since each ring requires different injection energy, magnetic field in the injector linac has to be changed pulse by pulse according to the characteristic of the beam [7]. By means of PPM simultaneous, top-up injection to several separated rings could be accomplished. Every pulse corresponds to a beam mode while every beam mode contains several event codes [8,9].

The operator can set the beam mode sequence according to requirements of rings and the EVG will generate event codes sequence as well as sending to the EVR. Each event code has its own meaning, either for triggering particular component or indicating the pre-trigger signal of the next beam mode. The pre-trigger signal is extremely important because some critical devices like kicker magnet requires some charging time to work properly [10].

System Set-up of Main Timing Station

The Main Timing Station is the core part of our Event Timing System. Figure 3 is the schematic views of the Main Timing Station. Three EVGs and one EVR are constructed as three-layers system. One EVG (upper-EVG) is configured as the main events trigger while the other two EVGs (lower-EVG) in the downstream will receive signal from middle EVR and generate actual event codes to control substations. These modules are placed in the VME64x sub-rack. The lower-EVGs are utilized owing to the requirements of the Damping Ring operation. One lower-EVG controls the LINAC before the DR (upstream LINAC) while the other manages the beam after DR (downstream LINAC).

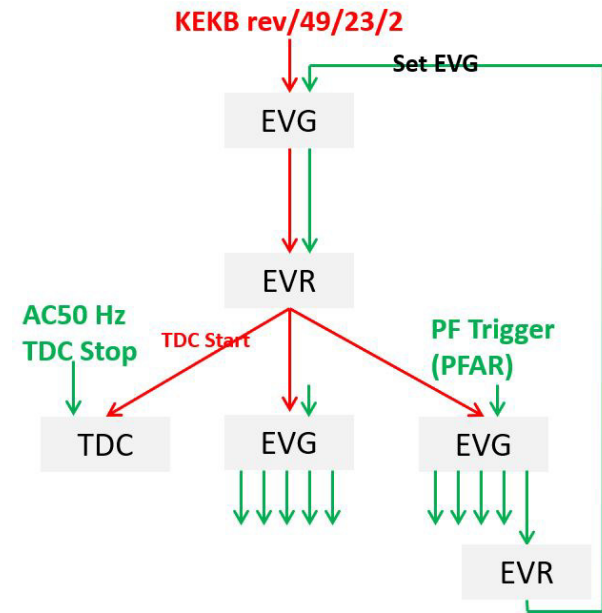

Figure 3: The Main Timing Station consists of three EVGs, one EVR, a TDC, two fanout modules and a distributed shared memory module.

Besides, the time-to-digital converter (TDC) and the distributed shared memory are configured in the IOC [11]. Since the LINAC hardware must run with the same phase of AC power 50 Hz (AC50) to maintain stable operation, the TDC module was installed for monitoring AC50 and synchronizing the MR injection operation. A 50 Hz generator module whose input is the AC power supply would generate the AC50 NIM standard signal.

Because of the restriction of the MR revolution frequency, the “rough” synchronization system for the MR injection is developed to reach our demand and here, for convenience, we call this “rough” synchronization system “16/18 sequences injection”. The detail of this algorithm is described in this paper [1]. With the help of “16/18 sequences injection”, every pulse is synchronized with AC50 despite of the fluctuation of AC50. The distributed shared memory is used for fetching the delay value after the calculation of bucket selection in another IOC and setting to the lower-EVG.

Trigger Line

Figure 4 show the trigger line of the Main Timing Station IOC. The upper-EVG receives MR revolution frequency signal to trigger event sequence and current beam mode event will be sent slightly earlier than next beam mode event (we call it ‘pre-trigger’). This pre-trigger signal causes two lower-EVGs perform PPM operation which changes software sequencer event code and timestamp to next pulse’s value. After a fixed delay time, current beam mode event will trigger the two lower-EVGs’s hardware sequencer to send out actual event codes to sub-stations. The delay time of two lower-EVGs depends on the measurement value of the AC50 through TDC. IOC reads the TDC value and set back to lower-EVGs hardware sequencer by EPICS record. Consequently, every pulse beam is always synchronized with the AC50 by means of this technology.

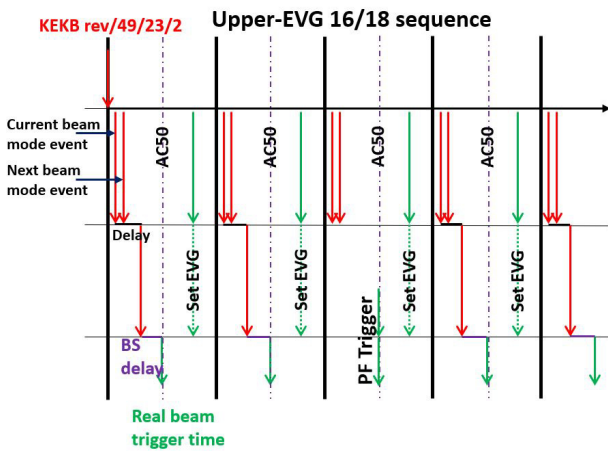

Figure 4: The trigger lines of the Main Timing Station.

To guarantee the beam trigger signals are delivered to devices, we install an EVR in the downstream of lower-EVG to receive the real trigger signal and use its output as a ‘Set EVG’ signal to update the yet changed software sequencer value to the two lower-EVGs’s hardware sequencer. In next pulse, this hardware sequencer would be triggered by next pulse’s current beam mode event.

For the beam transferring to PF (PF/AR) ring, a special case is that the hardware sequencer trigger source is PF (PF/AR) trigger signal instead of the current beam mode event. The PF (PF/AR) trigger signal is the output of triple-

sync module which receives PF (PF/AR) revolution frequency, event clock and AC50 as input.

EVENT TIMING DIAGNOSTIC SYSTEM

Theoretically, the timing system in SuperKEKB must operate periodically in 50 Hz, many devices like power supply, pulsed magnets and beam position monitors would be triggered every 20 ms for assuring that bunches are accelerated at relative the same location. And only 2 ms width of timing fluctuation is accepted [12]. However, during the operation we noticed that the time interval between kicker charge trigger and beam trigger is abnormal. And that may cause unstable beam and if beam bunch is not correctly transferred, in the worst situation, the beam would hit the Belle II detector and damage it. Besides this, lack of a reliability monitoring system makes it difficult to evaluate whether correct event codes are received by devices or not.

Apart from that, during the 21st KEKB Accelerator Review Committee in 2016, it was suggested that an operational diagnostic program of event system is needed. The collection of the event codes and timestamp information received in EVR is beneficial to diagnose abnormal events and avoid erroneously trigger.

Data Acquisition

In order to improve the stability and maintenance of timing system, an EVR based fault diagnosis system is developed to record all the events information. The MVME5500 on-board CPU controller and VxWorks-6.8.3 is used for developing this system. Two EVRs are installed in the VME rack to monitor upstream LINAC and downstream LINAC timing signals separately. A straightforward method to record all event codes used in injector linac is to create a number of EPICS PVs and monitor all of them using Channel Access. After practical tests, we found that the VME CPU is not fast enough to handle nanosecond level Channel Access data transmission and many event data would lost. Concerning this, a substitution data transmission approach, Network File System (NFS) protocol, is adopted. Figure 5 is the picture of the fault diagnosis system.

The NFS is a distributed file system protocol, allowing a user on a client computer to access files over a computer network much like local storage is accessed [13]. The source code of mrfioc2 module is modified so that an EPICS thread is created aiming for directly write event code and its timestamp information to local hard disk. Inside this EPICS thread, a large size ring buffer is created to buffer the event code and timestamp from the EVR FIFO area. Under this circumstance, one thread is used to receive the event code from EVR hardware and the other thread buffers them and send them by NFS protocol. Since we utilize the low-level system call, the CPU load is dramatically decreased and this system is very stable.

Content from this work may be used under the terms of the CC BY 3.0 licence (© 2019). Any distribution of this work must maintain attribution to the author(s), title of the work, publisher, and DOI.

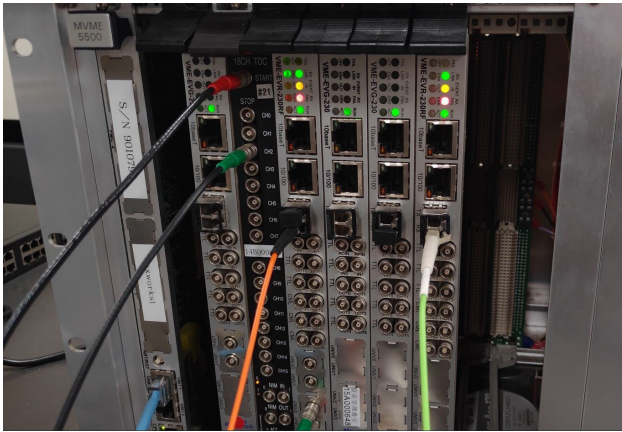

Figure 5: Two EVRs are installed in VME crate to record all the event codes and timestamp from upstream LINAC and downstream LINAC, respectively.

Data Processing

Every day hundreds of megabytes data will be saved to hard disk. Noted that the binary format file rather than ASCII format is chose to save the hard drive space and reduce the network transmission burden. To check these data we developed a program using Python script to identify the abnormal conditions. The sequence of event code is checked as well as the time interval of continuous beam mode. The time interval threshold is set to eliminate system error and distortion. The results of diagnosis are sent out by email to notify the control group person as well as saved to the hard disk. This Python script automatically runs every day.

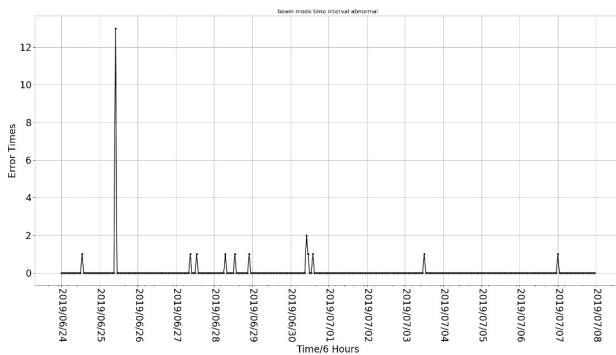

Figure 6: The abnormal beam mode occurrence times during two weeks before the summer maintenance of SuperKEKB in 2019.

Figure 6 is the picture of detected abnormal event sequences including repeat beam mode and unusual beam mode time intervals. The reason of such abnormal situations will be explained later.

FAULT DIAGNOSIS

Based on the analysis of the statistic data. We found that some beam modes are wrongly triggered twice as well as

time interval between some beam modes are abnormal. After detailed analysis, we categorize these data as two main abnormal conditions. Both of them will be thoroughly explained.

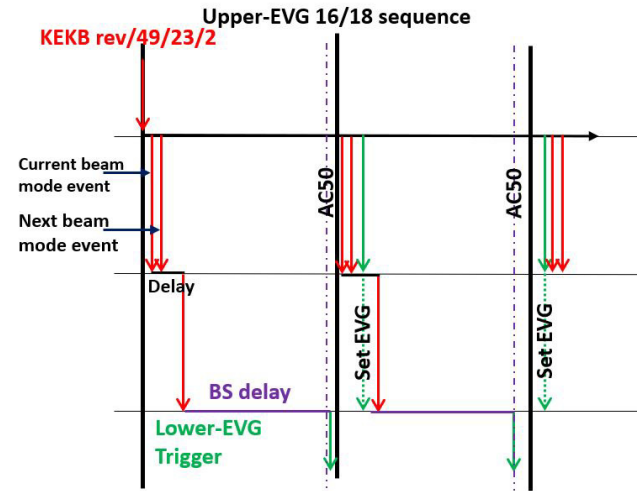

Figure 7: Too long delay of AC50 cause the ‘Set EVG’ signal arrives late than next beam mode event.

Beam Mode Replacement

This kind of abnormal condition can be described as current beam mode is replaced by the next beam mode. As the Fig. 7 shows, owing to the drastically drift of AC50 and the change of “16/18 sequences injection”, The AC50 signal comes very late and thus ‘Set EVG’ signal is later than next beam mode’s pre-trigger which means hardware sequencer’s value is changed to subsequently beam mode. The current beam mode is substituted by next beam mode. Based on our log data, such situation might occur when AC50 drift value is larger than 1 ms every 16/18 pulses.

Redundant Beam Mode

When we checked the timestamp information of the log data, sometimes an extra beam mode is inserted between a positron mode and a PF (PF/AR) beam mode. As the Fig. 8 shows, if a positron beam mode arrives earlier, with the trigger of lower-EVGs’s sequencer, the event codes are sent to the devices which causes a ‘Set EVG’ signal. This ‘Set EVG’ signal will change the sequencer trigger source to ‘PF Trigger’ and sequencer is triggered again later when ‘PF Trigger’ signal comes. Thus, an extra PF beam mode is sent. The unexpected delay value of the positron beam mode is the direct reason of this kind of error.

Solutions

To solve the beam mode replacement problem several actions could be took. Firstly, since the original reason is the drastic fluctuation of AC50, a filter could be used during the transformer process in 50 Hz generator to stabilize the AC50. Besides that, the AC50 comes too later is the direct

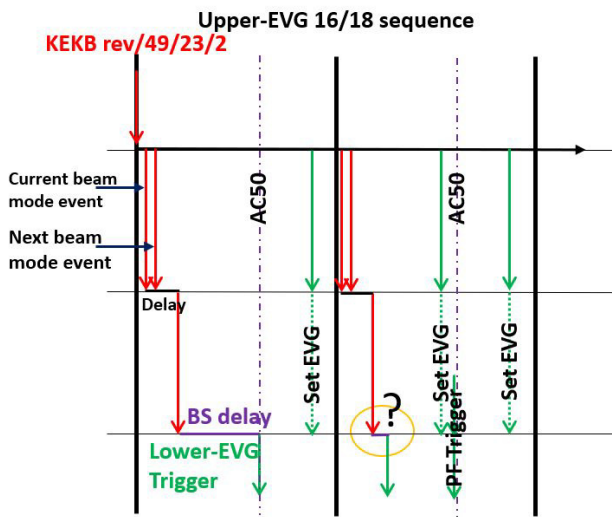

Figure 8: Owing to the wrong value of bucket selection delay, a beam mode signal is trigger earlier and results to the wrong occurrence of the next beam mode.

cause, so the interval between lower-EVG delay time and AC50 could be decreased by changing the ‘16/18 sequences injection’ setting.

The change of hardware sequencer trigger source makes it possible that PF (PF/AR) beam mode is triggered twice if positron beam mode arrives earlier than usual. Thus, the redundant beam mode error can be temporarily avoided by separating positron mode and PF (PF/AR) mode. Much more data is required to figure out the reason of the positron beam mode bucket selection abnormal delay value.

SUMMARY AND OUTLOOK

The stability of timing system is crucial system to maintain a steady operation of our project. The introduction of PPM technology and construction of the DR make it much more complicated to diagnose the potential fault. Thus, we develop an event fault diagnosis system to monitor the timing system signals and make fault analysis every day.

During the SuperKEKB phase-3 operation, we find several timing system abnormal conditions through our fault diagnosis system and after detailed inspection we find the flaw of our timing system in some extreme situations and correspondent suggestions based on the original cause and direct cause are proposed to improve the system. After the summer maintenance until the middle of October, SuperKEKB will start again and much more timing system data could be acquired by our fault diagnosis system which contributes to figure out deepest reason of abnormal beam mode. We believe this kind fault diagnosis system is of great significance not only for our timing system but also for other facility’s timing system.

Depending on the fault analyses, in the near future, we would implement a mechanism for on-line alarming to the

operators. Furthermore, by using the event timing data and AC50 signal, we plan to develop a fault prediction system based on time series forecasting models or deep learning algorithms. Later developments will be investigated based on the achievements.

REFERENCES

- [1] H. Kaji *et al.*, “Installation and commissioning of new Event Timing System for SuperKEKB”, in *Proceedings of 12th Annual Meeting of PASJ*, Tsuruga, Japan, 2015, paper FROL15.
- [2] T. Korhonen, “Review of Accelerator Timing Systems”, in *Proc. 7th Int. Conf. on Accelerator and Large Experimental Control Systems (ICALEPCS’99)*, Trieste, Italy, Oct. 1999, paper FB1101, pp. 167–170.
- [3] MRF website, <http://mrf.fi/index.php/timing-system>
- [4] Mrfioc2 website, <http://epics.sourceforge.net/mrfioc2>
- [5] *EPICS device driver for MRF VME-EVG-230*, Sep. 2011, pp. 6-9; <http://epics.sourceforge.net/mrfioc2/evg-usage.pdf>
- [6] K. Akai *et al.*, “SuperKEKB collider”. doi:10.1016/j.nima.2018.08.017
- [7] Y. Enomoto *et al.*, “Pulse-to-pulse Beam Modulation for 4 Storage Rings with 64 Pulsed Magnets”, in *Proc. 29th Linear Accelerator Conf. (LINAC’18)*, Beijing, China, Sep. 2018, pp. 609–614. doi:10.18429/JACoW-LINAC2018-WE1A06
- [8] K. Furukawa *et al.*, “Pulse-to-pulse Beam Modulation and Event-based Beam Feedback Systems at KEKB Linac”, in *Proc. 1st Int. Particle Accelerator Conf. (IPAC’10)*, Kyoto, Japan, May 2010, paper TUOCMH01, pp. 1271–1273.
- [9] N. Higashi *et al.*, “Construction and Commissioning of Direct Beam Transport Line for PF-AR”, in *Proc. 8th Int. Particle Accelerator Conf. (IPAC’17)*, Copenhagen, Denmark, May 2017, paper WEPAB044, pp. 2678–2680.
- [10] H. Sugimura *et al.*, “Synchronized Timing and Control System Construction of SuperKEKB Positron Damping Ring”, in *Proc. 16th Int. Conf. on Accelerator and Large Experimental Control Systems (ICALEPCS’17)*, Barcelona, Spain, Oct. 2017, pp. 229–231. doi:10.18429/JACoW-ICALEPCS2017-TUCPL02
- [11] T. Suwada *et al.*, “Wide dynamic range FPGA-based TDC for monitoring a trigger timing distribution system in linear accelerators”, *Nucl. Instr. Meth.*, vol. 786, pp. 83–90, 2015. doi:10.1016/j.nima.2015.03.019.
- [12] H. Kaji *et al.*, “Bucket selection system for SuperKEKB”, in *Proceedings of 12th Annual Meeting of PASJ*, Tsuruga, Japan, 2015, paper THP100.
- [13] *vxworks kernel programmers guide 6.8*, Wind River, Alameda, CA, USA, Nov. 2009, pp. 433-440. http://read.pudn.com/downloads305/sourcecode/embedded/1357999/vxworks_application_programmers_guide_6.8.pdf