

Stabilization and Positioning of CLIC Quadrupole Magnets with sub-Nanometre Resolution

S. Janssens*, K. Artoos, C. Collette**, M. Esposito,
P. Fernández Carmona, M. Guinchard,
C. Hauviller, A. Kuzmin, R. Leuxe and R. Morón
Ballester

Paper Reference MOMMU005

* PhD student ULB-CERN

** Associate ULB

CLIC Stabilization Requirements

- Compact Linear Collider
 - ~48 Km e- e+ accelerator
 - 3992 Main Beam Quadrupoles
- Stabilization r.m.s.
 - Vertical 1.5 nm > 1 Hz
 - Horizontal 5 nm > 1 Hz

$$\sigma_x(f) = \sqrt{\int_f^\infty \Phi_x(\nu) d\nu}$$

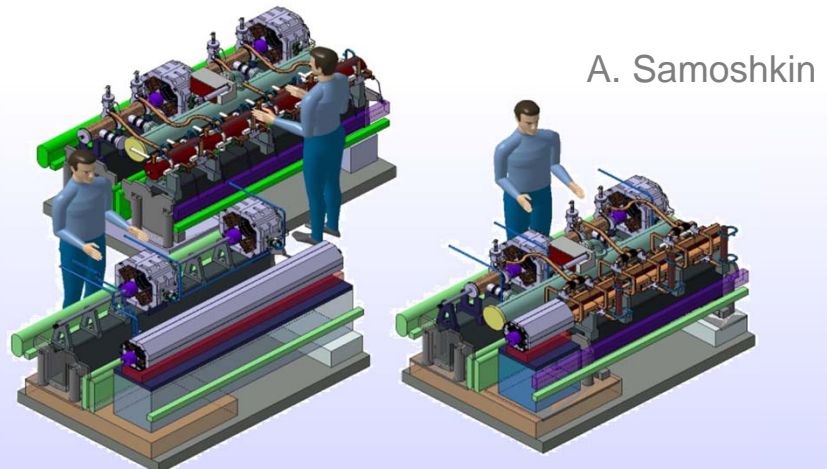

Type 4: 2m, 400 kg Type 1: 0.5 m, 100 kg

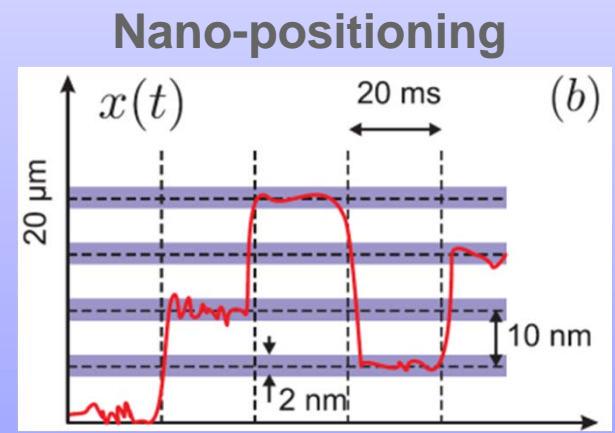
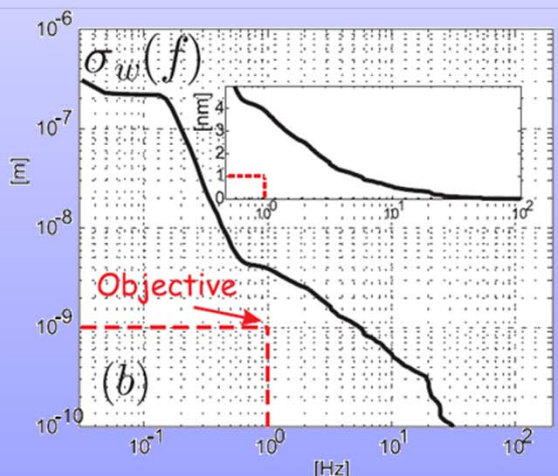
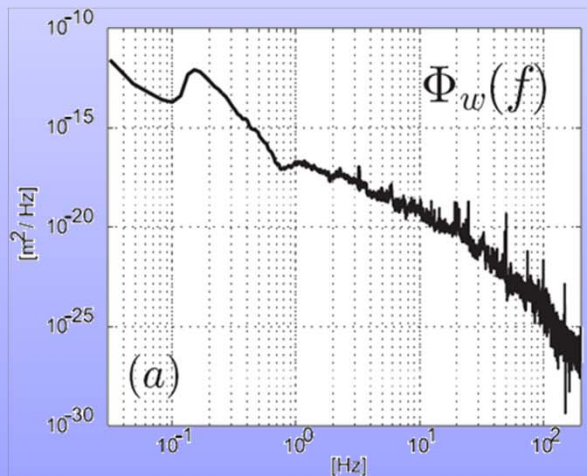

Stabilization strategy

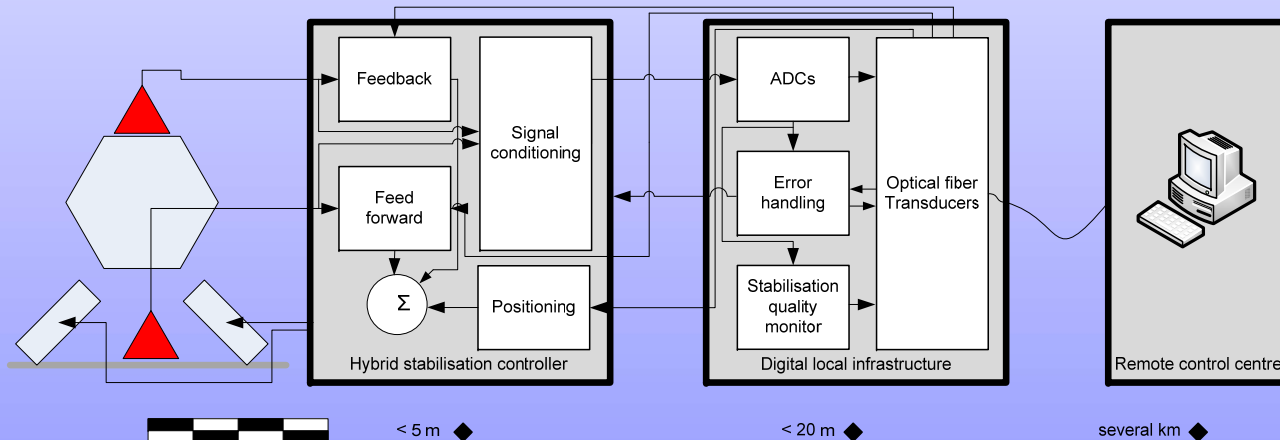
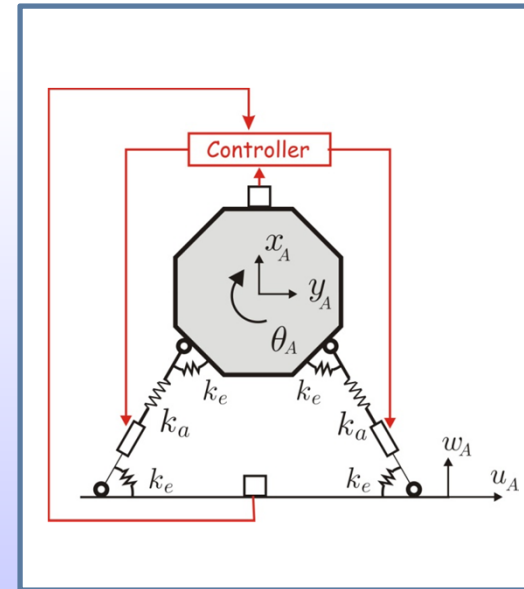
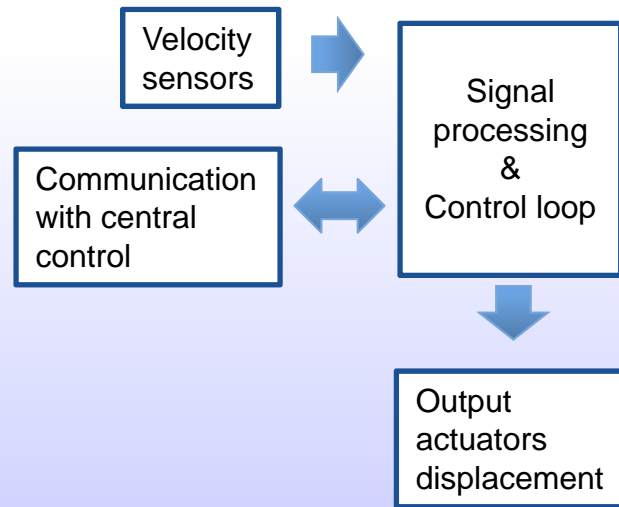

Stabilization strategy

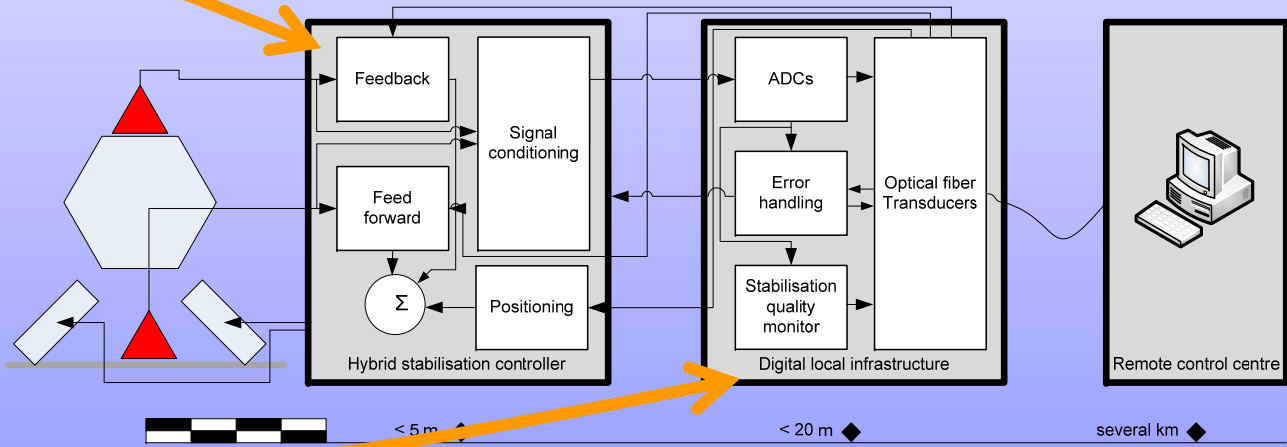
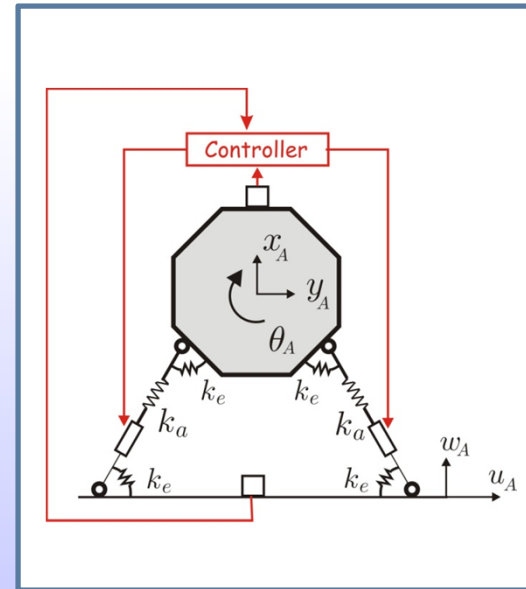
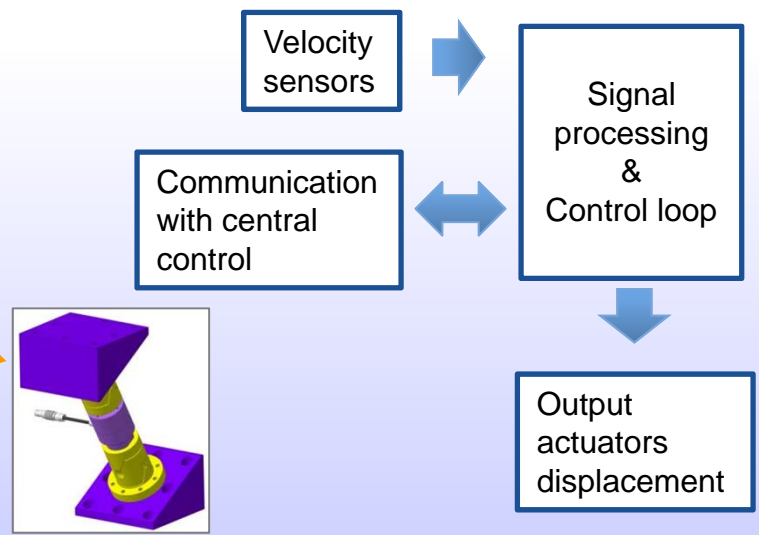
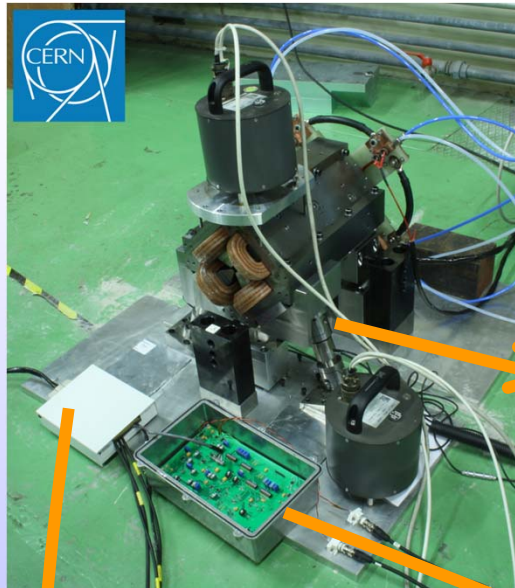

Results and Conclusion



Membrane
1 d.o.f

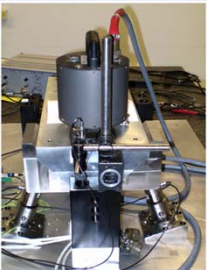

Tripod
2 d.o.f

Transmissibility

Integrated r.m.s.

Long Term
Stability

Positioning

Results and Conclusion



Membrane
1 d.o.f

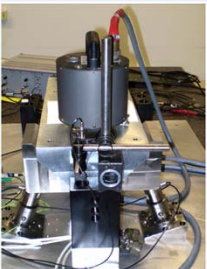

Tripod
2 d.o.f

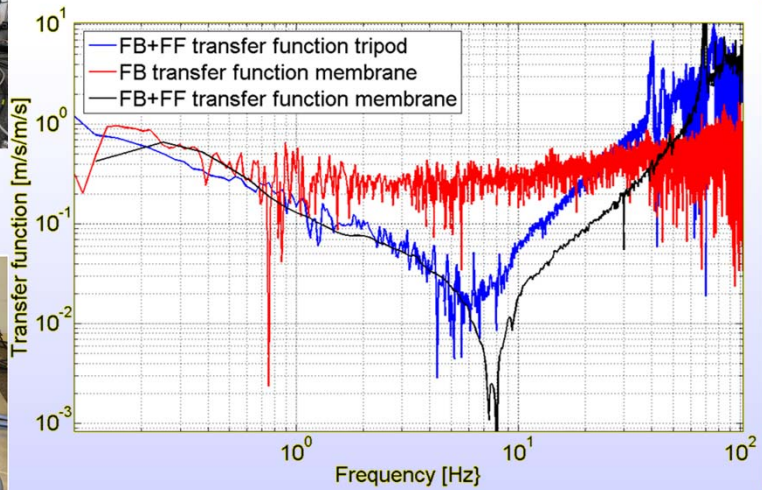

Integrated r.m.s.

Long Term
Stability

Positioning

Results and Conclusion



Membrane 1 d.o.f

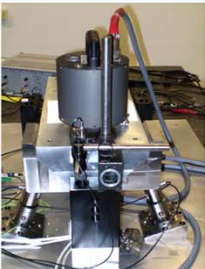

Tripod 2 d.o.f

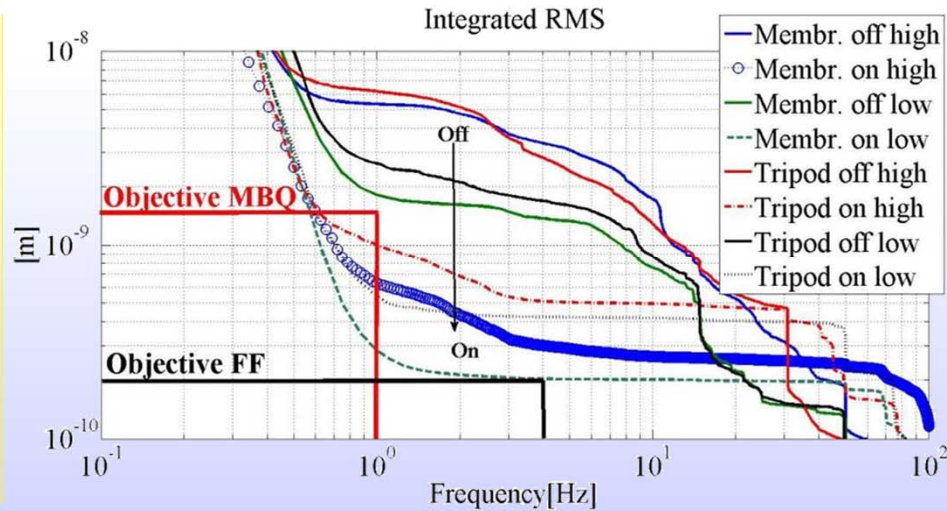
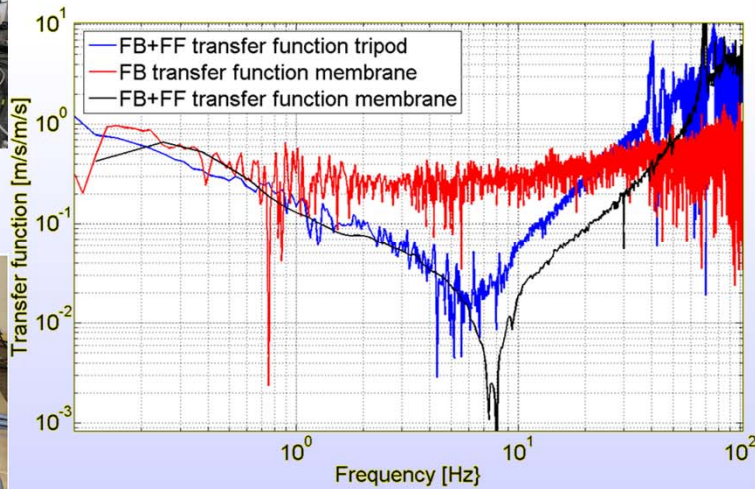

Long Term Stability

Positioning

Results and Conclusion



Membrane
1 d.o.f

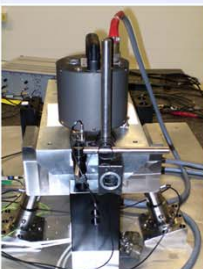

Tripod
2 d.o.f

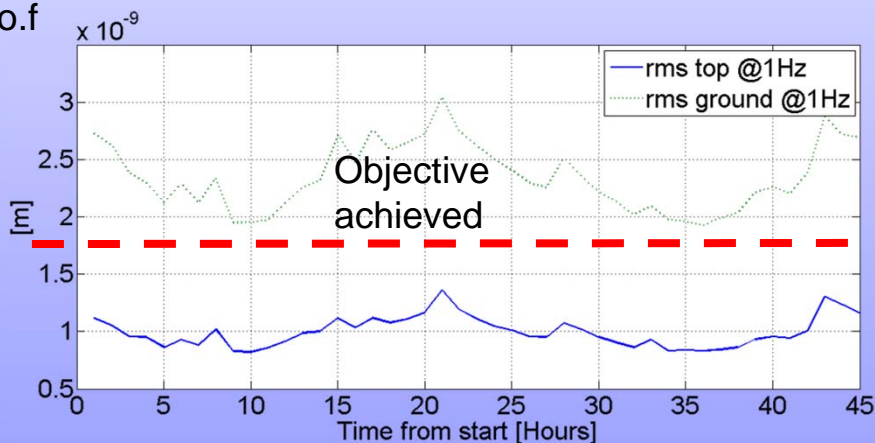
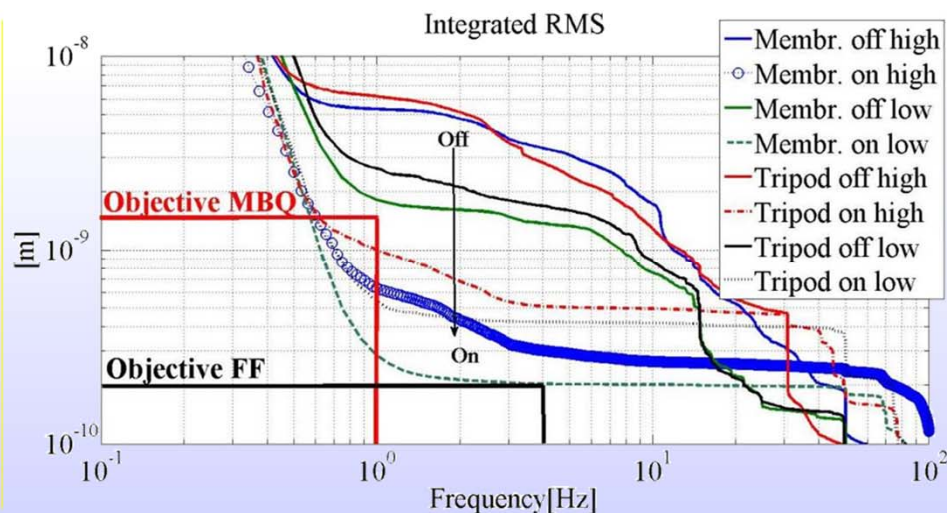
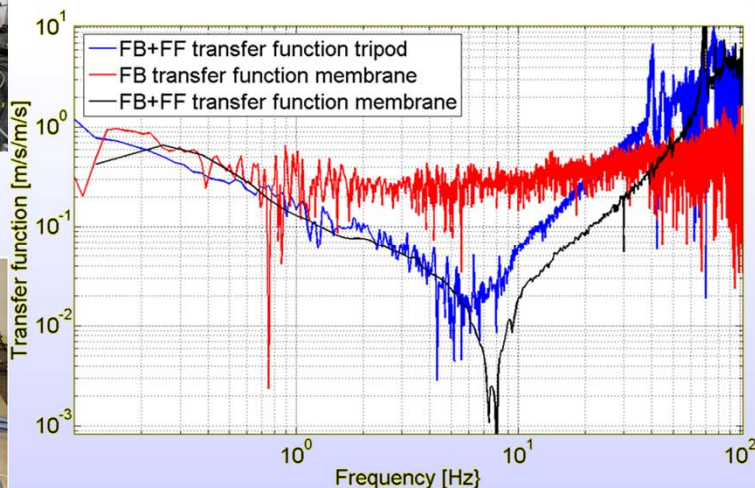

Positioning

Results and Conclusion



Membrane 1 d.o.f

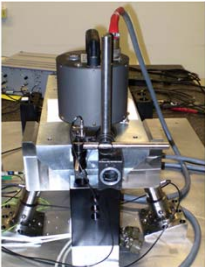

Tripod 2 d.o.f

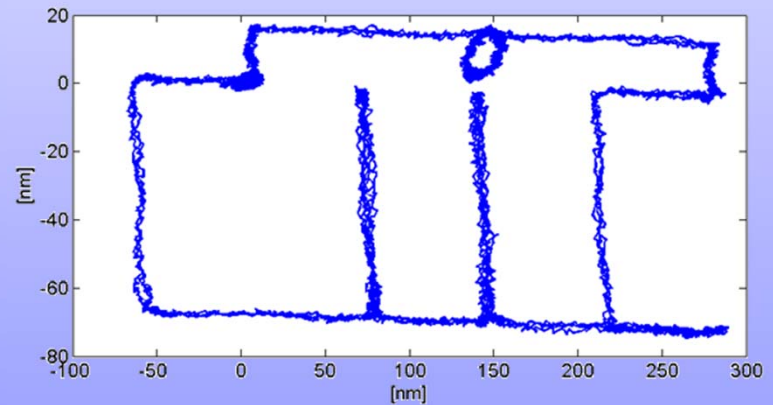
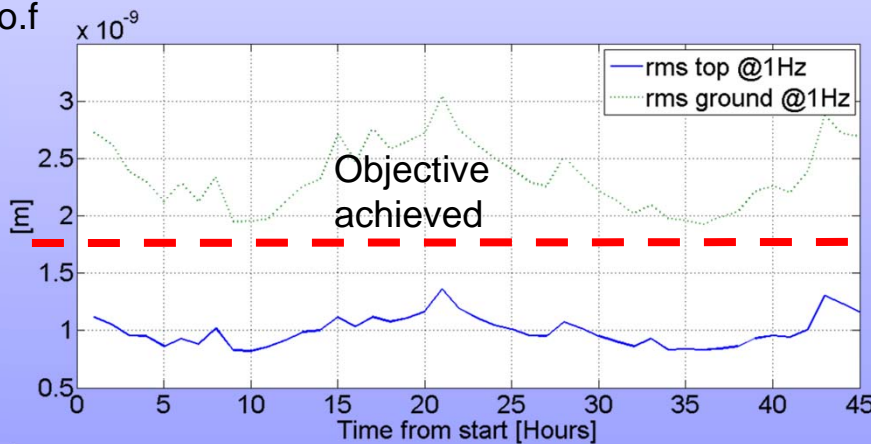
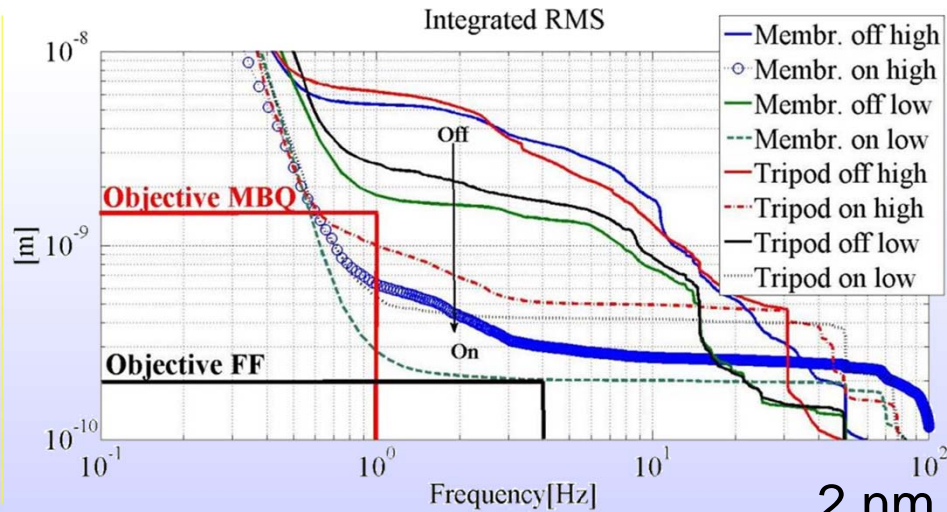
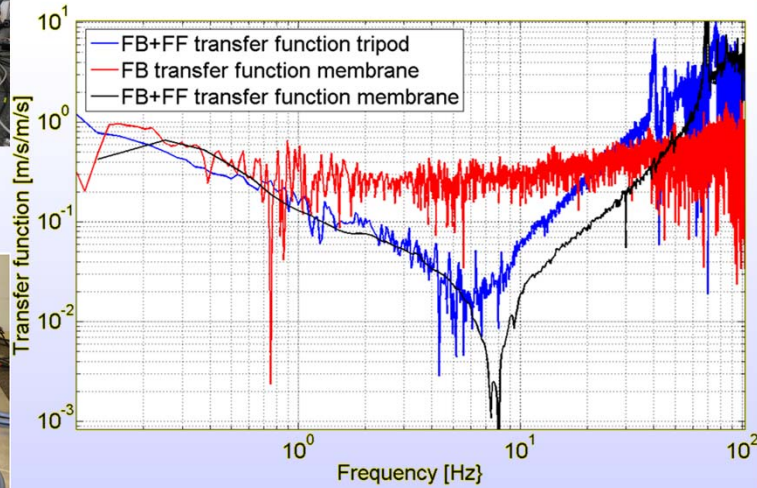

2 nm

