

LHC DIPOLE MAGNET SPLICE RESISTANCE FROM SM18 DATA MINING

H. Reymond, O. O. Andreassen, C. Charrondiere, G. Lehmann Miotto, A. Rijllart, D. A. Scannicchio (CERN, Geneva, Switzerland)

INTRODUCTION

After the melting of a busbar interconnect splice in sector 34 in September 2008 during hardware commissioning, a special campaign was initiated to find bad splices by calorimetric and quench protection system (QPS) measurements. They were made in sectors 12, 56, 67, 78 and 81. The sectors 23, 34 and 45 were not measured, due to the fact that they were not cold at the time of the campaign. No bad splices were found within the detection limits of 20 nΩ, but two bad magnet splices of about 100 and 50 nΩ were found inside two of the dipole magnets. When these magnets were opened 'hardly soldered' splices were indeed found between poles and apertures. The CERN Chamonix Workshop (January, 2009) therefore gave a recommendation to look back in SM18 data and try to find back indications for bad splices looking at the old provoked quench test data. A working group was formed with members from the Technical, Engineering and Physics departments to make this analysis. It was decided to study with priority the magnets present in sectors 23, 34 and 45, for which the least precise measurements existed. Furthermore only dipole data would be analysed, as the quadrupoles were connected in quite a different way in SM18 than in the LHC, making the splice measurements very uncertain.

VOLTAGE TAPS LAYOUT OF A LHC DIPOLE

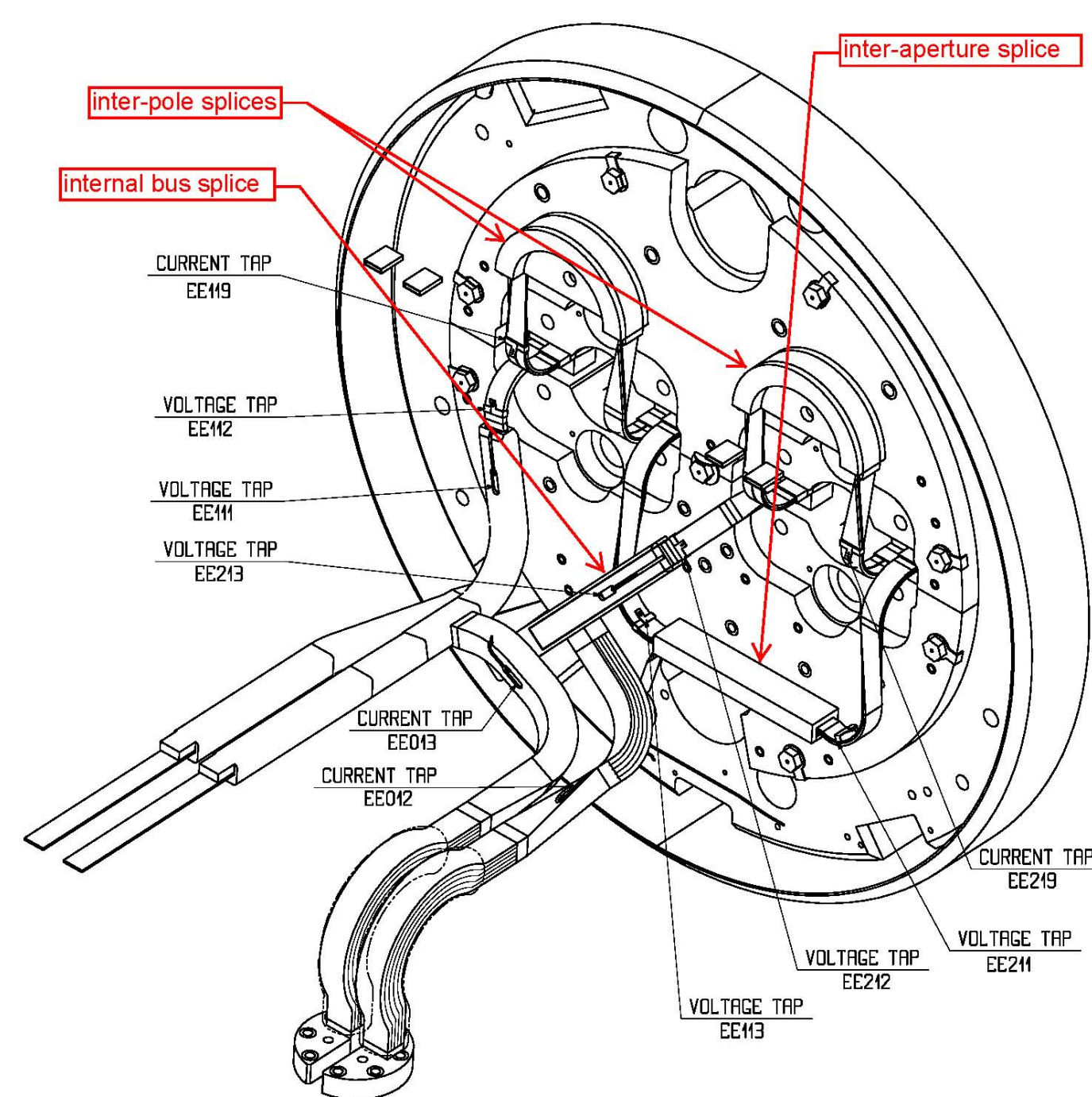

Main dipole splices (as in MBB).

Only differential measurements: result depends on the value of the other resistances involved.

Formulas

$$V_{D1_L-Ua} = V_{D1_L-U} - V_{bus_Ext}$$

$$V_{D2_U-La} = V_{D2_U-L} - V_{bus_Int}$$

$$V_{bus_Exta} = V_{bus_Ext} - V_{supra_Ext_lead} = V_{diode} \text{ for MBA}$$

$$V_{bus_Inta} = V_{bus_Int} - V_{supra_Int_lead} = V_{diode} \text{ for MBB}$$

Voltage tap signals and formulas used for the analysis.

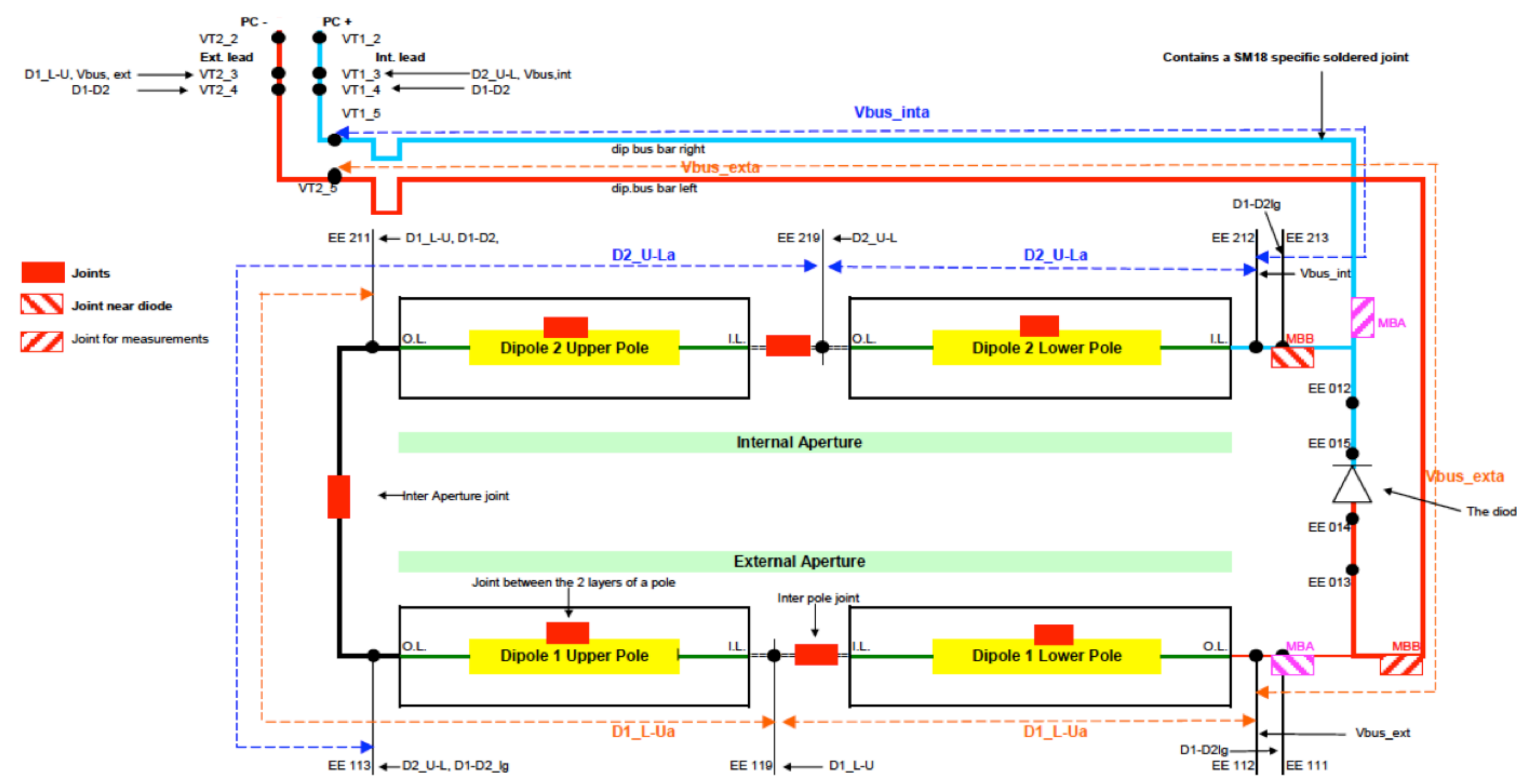

Electrical connections layout of a LHC dipole.

AVAILABLE DATA FROM SM18 MAGNET RECEPTION AND QUALIFICATION TESTS



View of half of the SM18 test benches facility.

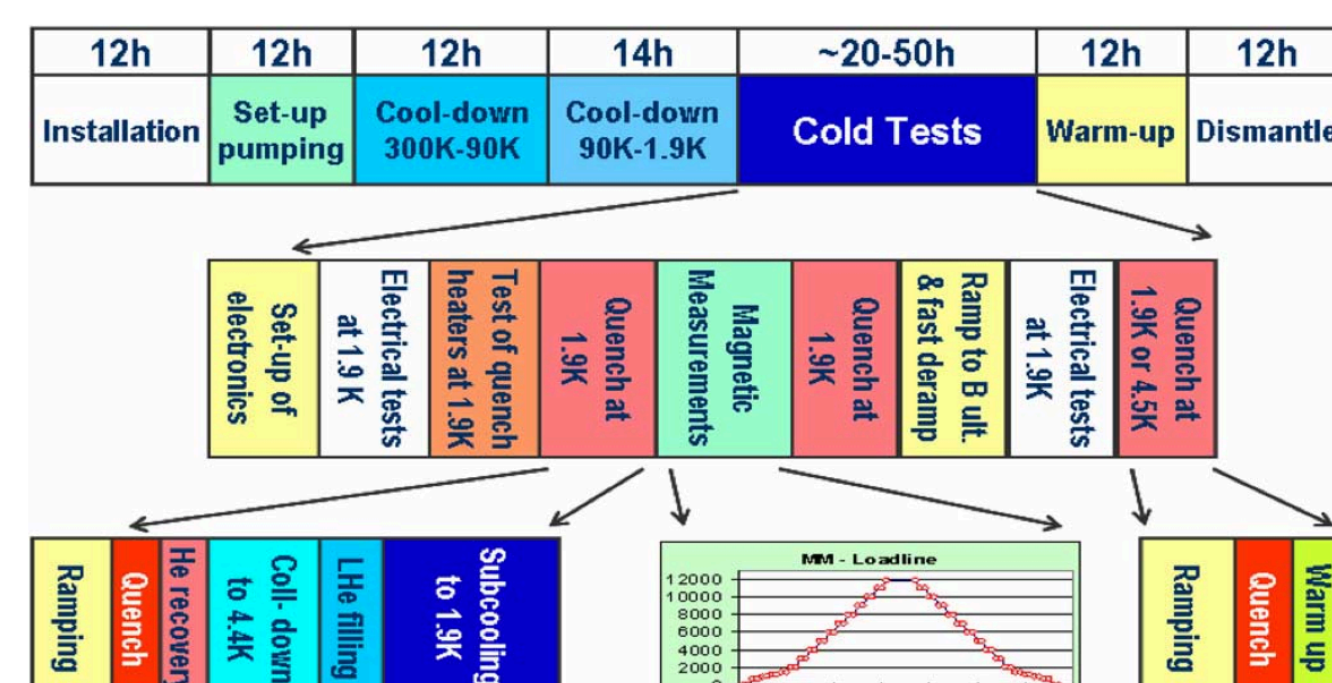

Main phases of the standard test cycle for the LHC main dipoles.

- ha - Quench heater test - heater delay - 1.5 kA - 1/2 HF
- hb - Quench heater test - heater delay - 1.5 kA - 1/2 LF
- hc - Quench heater test - heater delay - 1.5 kA - 1/2 LF
- ka - Quench heaters test - minimum energy - protection all HF
- kb - Quench heaters test - minimum energy - protection 1/2 HF
- kc - Quench heaters test at 3 kA - minimum energy - protection all HF
- u - Ultimate field reached (manual trigger)
- ub - 12000 A reached (manual trigger)

List of the SM18 test files used for this data mining.

On average 15 files per magnet, with 1530 measured magnets, taking into account those re-measured, which give us 23,000 files to be analysed

ANALYSIS DONE BY THE AUTOMATED TOOL

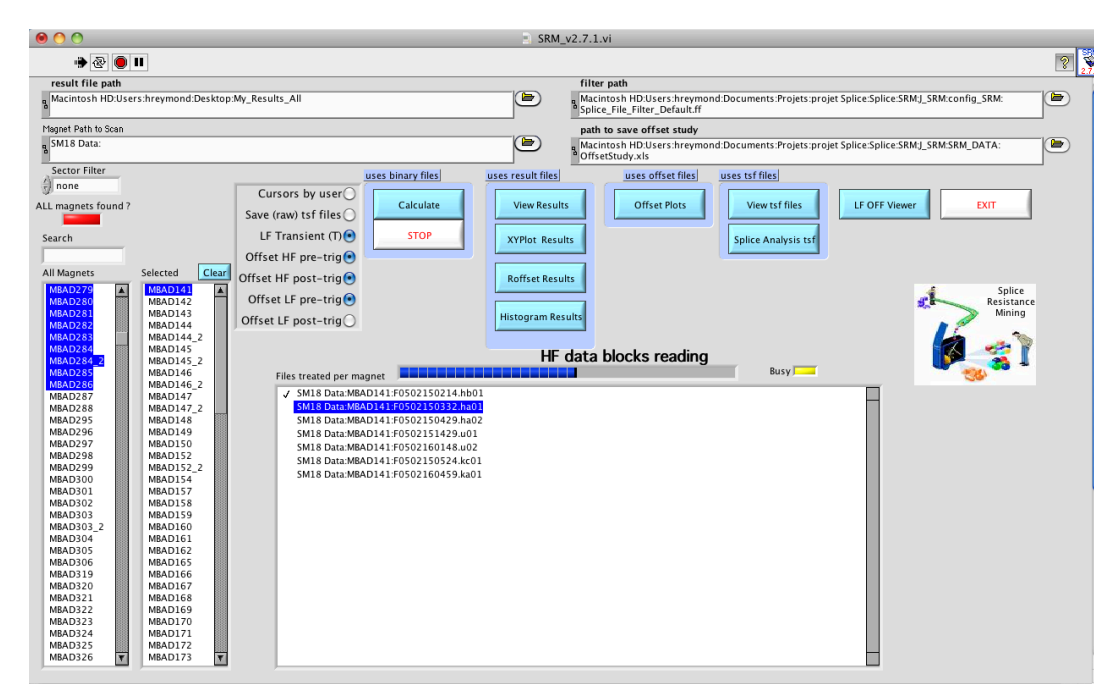
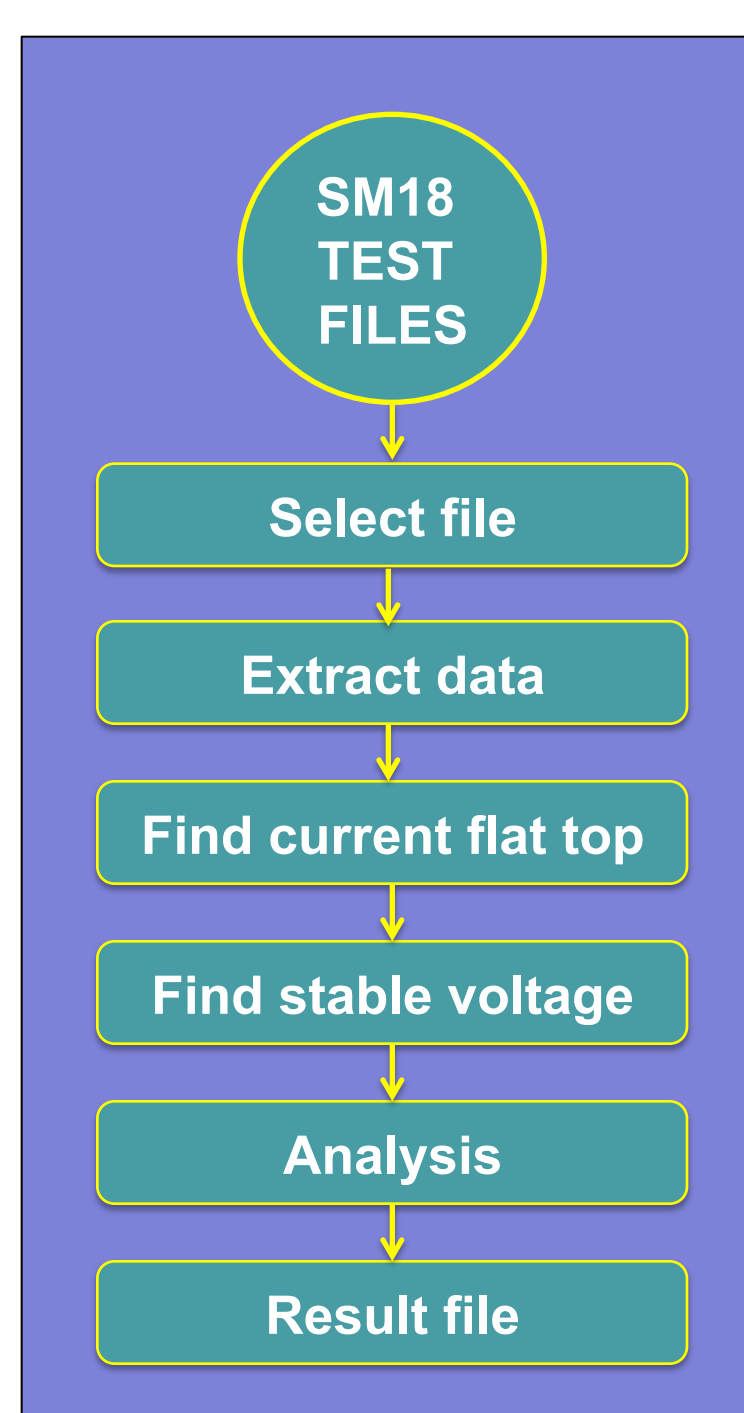

Main panel of the analysis launcher.

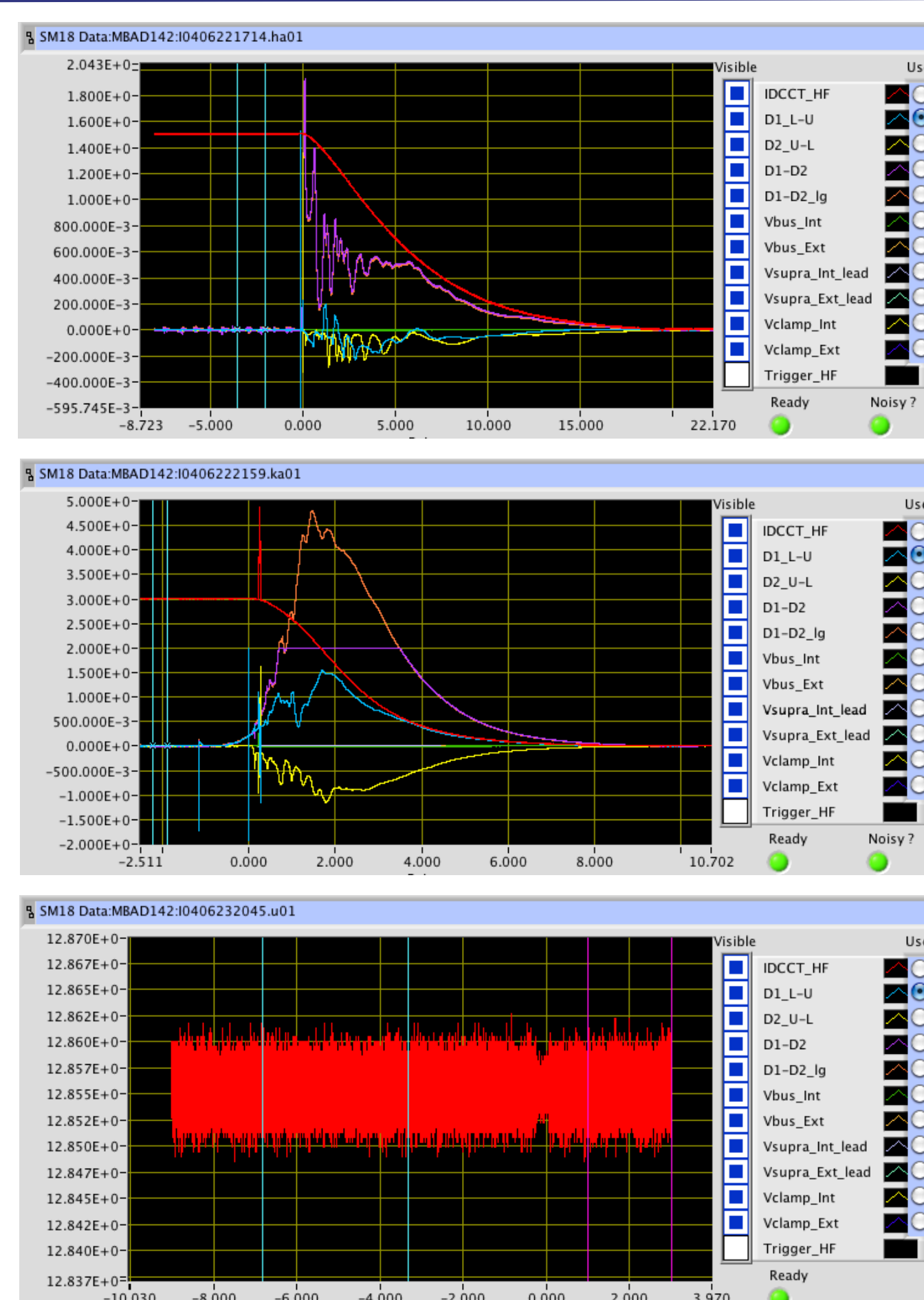

Data files, for 1.5 kA, 3 kA and 12 kA.

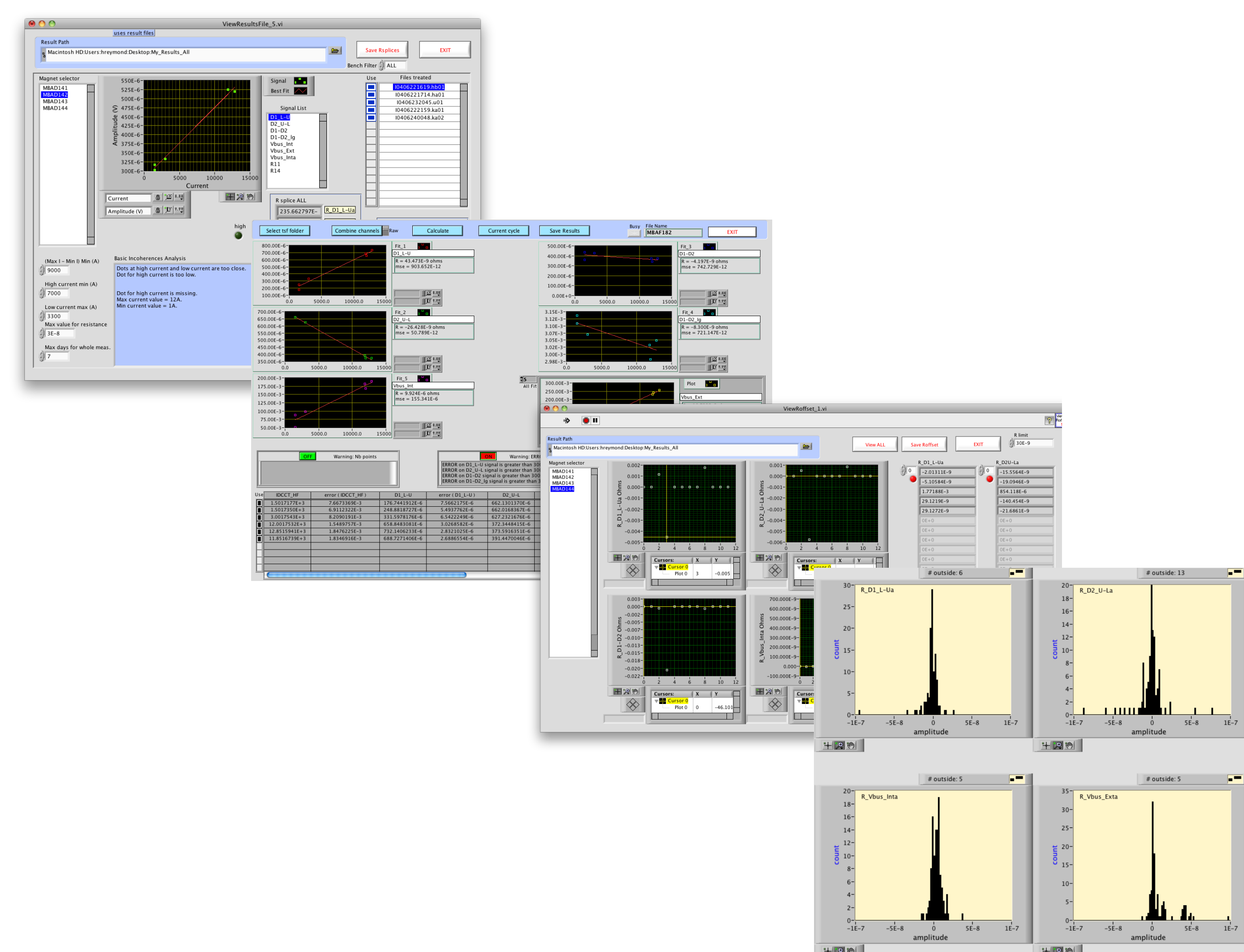

Views of some of the sub-panels analysis.

FACTS AND DIFFICULTIES

Method

- Signals taken at I (A) and U (V) plateau
- Available currents: 1.5 kA -> 12.8 kA
- Analysis: Take all available I-V points for a magnet -> a straight line fit shall give the value of the Resistance according to Ohm's law.

Linear Fit

This method leaves us with ~ 30% of the 1530 measurements (1274 magnets) with at least one resistance above 25 nΩ.

Problems:

- Not enough or well separated data points.
- Drift of offsets.
- Wrong recording of gain settings (factor 400) on V_{bus_Int} and V_{bus_Ext} had to be corrected on ~10% of the files.
- Some benches showing systematically high V_{bus} signals.

Offset Correction

- ha and hb data (I_{max} = 1.5 kA) have a long enough buffer at 0 A to allow voltage signals to stabilize.
- Ohms law can be applied in the following way: $R = (V_{max} - V_0) / I_{max}$
- While the offset subtracted, signal has a RMS width of 20 μV (~15 nΩ at 1.5 kA).
- This method can only be applied to magnets which have data at 1.5 kA.
- The offset method works only if the signals stabilize after the induced quench.
- SM18 benches I and J have unstable post-quench signals on D2.

CONCLUSION

During this data-mining campaign aimed at finding bad magnet splices, more than 23,000 magnet performance measurements were scrutinized. This has been done possible by developing a specific analysis tool, based on an existing LabVIEW™ data viewer. Adding automated pattern and signal extraction and writing analytical algorithms, permitted to get an overview of the splice resistance of four LHC sectors. From this, five magnets having high internal splice resistance have been flagged.