

CONTROL SYSTEM FOR MAGNET POWER SUPPLIES FOR NOVOSIBIRSK FREE ELECTRON LASER

Yu.M.Velikanov, V.F.Veremeenko, N.A.Vinokurov, A.A. Galt, B.A.Dovzhenko, V.R.Kozak,
E.A.Kuper, L.E.Medvedev, A.S.Medvedko, S.S.Serednyakov.

BINP SB RAS, Novosibirsk, Russia

Abstract

The control system for the magnetic system of the free electron laser (FEL) is described. The characteristics and structure of the power supply system are presented. The power supply control system based on embedded intelligent controllers with the CAN-BUS interface is considered in detail. The control software structure and capabilities are described. Besides, the software tools for power supply diagnostics are described.

INTRODUCTION

A high-power free electron laser based on the accelerator-recuperator [1] is under construction now at Budker Institute of Nuclear Physics. The first and second phases of the project were commissioned recently. As with other particle accelerator facilities, the magnetic system of the FEL is an important part of the installation. It consists of many magnetic elements of different types: bending magnets, quadrupole lenses, and correctors. In total, the first and second stages contain about 80 and about 120 magnetic elements, correspondingly. The windings of all elements are fed from DC current power supplies designed and manufactured at BINP. These power supplies are in turn controlled by analog-to-digital and digital-to-analog converters (DACs and ADCs), which are connected to the control computer with the CAN-BUS interface [2]. The control system of the power supplies of the magnetic elements is described in this article.

POWER SUPPLY SYSTEM

As mentioned before, the magnetic system of the FEL consists of several types of magnetic elements. The elements differ in their influence on the electron beam and the amount of consumed DC current, which results in the use of power supplies of various types. The main characteristics of the power supplies applied are shown in Table 1. This table also presents the quantity of power supplies of different types for the first and second stages of the FEL. All other characteristics of the power supplies are presented in detail in [3]. One can see from Table 1 that the amount of low-power (3A and 10A) supplies used is large, while the number of high-power (300A, 1000A, and 2500A) supplies is very small. In addition, the low-power supplies are very small and do not require water cooling. Therefore it is very convenient to combine those numerous low-power supplies in one rack, their control joined in one multi-channel control device. At the same time, high-power supplies require a larger space and more

parameters to measure and control, and hence an individual control device.

Table 1: Main Parameters of the Power Supplies

I _{max} , A	U _{max} , V	Qty		Magnetic elements
		1st stage	2nd stage	
±3.0	12	90	125	Correctors
±10.0	20	54	70	Bending magnets, Quadrupole lenses
300	12	0	5	Bending magnets, Quadrupole lenses
1000	12	2	2	Bending magnets
2500	48	1	1	Undulator

CONTROL HARDWARE

As mentioned above, all control devices used in this system have the CAN-BUS interface and are connected to one CAN-line. Using the CAN standard for this system allows integrating the control of different power supplies, sometimes of different volume and considerably spaced. Depending on the details of this system operation, required accuracies, dimensions and consumed power, all power supplies could be divided into groups according to the method of their connection to the control hardware:

- 1) low-power supplies operated by multi-channel control devices and
- 2) high-power power supplies operated by precision single-channel control devices

For the first group, a **CANDAC16-CANADC40** pair is used. **CANDAC16** is a 16-channel digital-to-analog converter, and **CANADC40** is a 40-channel analog-to-digital converter. This pair is used to control a set of 16 power supplies. **CDAC20** devices are used for control of power supplies of the second group, which have higher accuracy in comparison with those of the first group, but one device can control only one power supply.

Table 2: Parameters of the Control Devices.

Parameter	Candac16	Canadc40	Cdac20
DAC resolution	16 bits	-	21 bits
DAC accuracy	0.05%	-	0.005%
DAC channels	16	-	1
ADC resolution	-	23 bits	23 bits
ADC accuracy	-	0.03%	0.003%
ADC channels	-	40	5

Scale (input/output)	10 V	10 V	10 V
Qty of devices used in the 1 st stage	10	10	3
Qty of devices used in the 2 nd stage	24	24	7
Qty of devices used in the 3 rd stage	24	24	12

All the above control devices are developed and manufactured at BINP [4]. Table 2 presents the main characteristics of all the devices as well as the quantity of devices applied in the 1st, 2nd and 3rd stages of the FEL.

Figure 1 shows the arrangement of the power supplies and their connection with the CAN-BUS.

The low-power supplies are grouped in sections, 16 power supplies in one section. Each rack contains up to 3 sections. Each section is controlled by a **CANDAC16-CANADC40** pair.

The way of connection of high-power supplies to their controllers depends on the size of the power supply and presence of additional electronics.

All above controllers are connected to a single CAN line, which is connected to the control IBM PC. It should also be noted that all control devices can operate both in the single-channel mode and the multi-channel one. This ability allows one to organize single-channel measurement of the output current of power supply “on demand”, without interrupting the usual measurement cycle for the output currents of other power supplies.

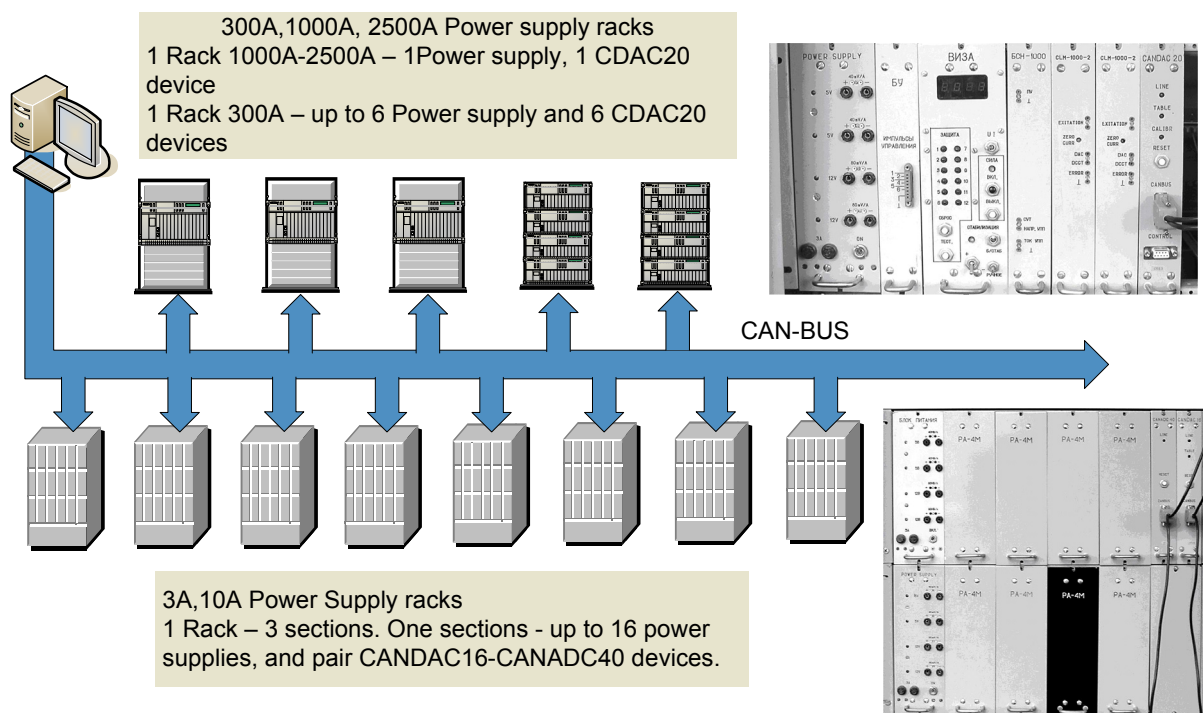

Figure 1: Arrangement of the power supplies and their connection to the CAN-BUS.

CONTROL SOFTWARE

The software controlling the operation of all the power supplies is implemented in one application. The main features of the program are as follows:

- 1) an advanced user interface, allowing full control of the power supply operation;
- 2) remote control of all the power supplies using the Epics Channel Access Server, i.e., one can set and check the currents of the magnetic elements from any other computer in this local network;
- 3) demagnetization of all magnetic elements of the system via applying current of an alternate polarity to an element and amplitude damping from the maximum source current to zero;

- 4) the possibility of saving/loading the currents of all or an arbitrary set of the power supplies;
- 5) a set of tools for diagnostics of the power supply operation: real-time verification of the output current and measurement of ripples in an automatic mode;
- 6) similar operation in all FEL configurations: the 1st, 2nd and 3rd stages.

The main window of the control software is presented in Fig.2. The power supplies and their states are shown in lines, containing the name of a magnetic element fed by this power supply and its current at this moment. The color of line and its content reflects the actual state of the power supply.

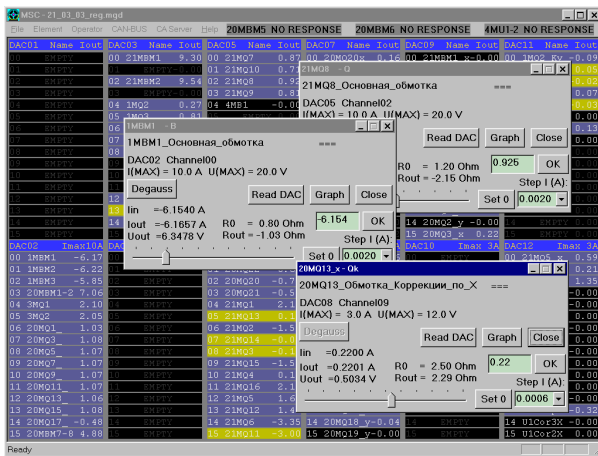

Figure 2: Main window of the control software.

Since the number of magnetic elements is very large, it is very difficult to find a particular element in this list. There is a mnemonic scheme of the entire FEL facility with magnetic elements that simplifies search for a required element. The scheme is shown in Fig.3.

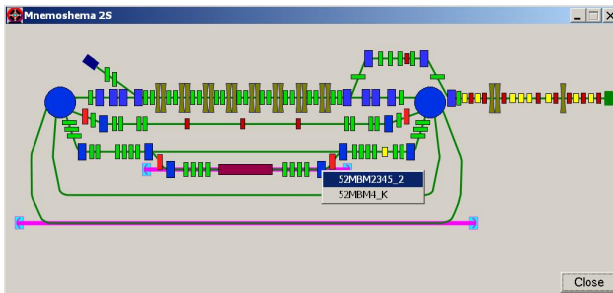

Figure 3: Mnemonic scheme of the FEL magnetic system.

To change current in a required element, the user has to open an individual dialog window, clicking on the corresponding element in the mnemonic scheme or the corresponding colored line in the main window.

As mentioned above, the control application also has some tools for diagnostics of the regularity of the power supply operation. One of them is the real-time comparison of current set for a power supply and a measured current value. If the difference exceeds a certain limit, the line in the main window that corresponds to this power supply is marked yellow (warning) or red (alarm). The program also watches the time stability of current set for a power supply. If the current changes in time by a value exceeding a certain limit, this power supply will be marked with color too.

Another diagnostic tool for the power supplies is a control of ripples of output current with frequencies of up to 500 Hz. To implement this, the test program runs a cycle of single-channel measurements on all ADC channels, measuring the output currents of all the power supplies. Processing of one power supply includes construction of a measurement array of a required length and mathematical treatment of the data, i.e. finding the

average current, maximum deviation and root-mean-square deviation of the current. Results are displayed in a separate window, shown in Fig. 4. The values of maximum deviation and root-mean-square deviation of current are presented graphically with vertical bars. The entire array of measurements is also displayed. The ripples, if any, can be detected by the magnitude of the color bars and analyzed in the graph of the array of measured values.

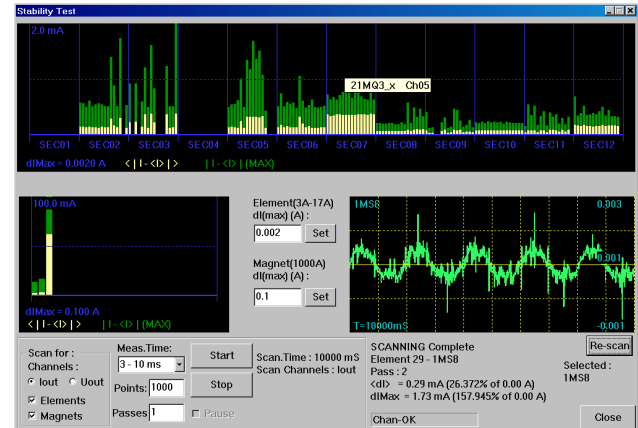

Figure 4: Window of the test of the power supply ripples.

In addition, for the purpose of remote control of the power supplies, the EPICS portable channel access server is built in the control application. Each power supply is presented with 3 process variables (PVs) on this server: a PV for the specified current, a PV for the measured current, and a PV for the measured voltage of the power supply.

CONCLUSION

The control system of the magnet power supplies has been operating for 8 years, demonstrating high stability and convenience of use. The diagnostic tools allow full control of the regularity of the power supply operation. The built-in EPICS channel access server allows integrating the control software to the EPICS-based control system.

REFERENCES

- [1] N.A. Vinokurov et al. Novosibirsk free electron laser facility: Two-orbit ERL with two FELs. Proceedings of FEL2009, TUOD01
- [2] <http://www.can-cia.org> CAN In Automation. 2009.
- [3] Yu.M.Velikanov et al. Free electron laser for Siberian centre for photochemical research: The control system for the magnet power supplies. Proceedings of RuPAC XIX, WEHP18
- [4] V.R.Kozak, E.A.Kuper. Microprocessor controllers for power sources. BINP preprint 2001-70, 2001.