

APPLICATION OF INTEGRAL-SEPARATED PID ALGORITHM IN ORBIT FEEDBACK *

K. Xuan[#], X. Bao, C. Li, W. Li, G. Liu, J. Wang, L. Wang,

NSRL, USTC, Hefei, Anhui 230029, China.

Abstract

The algorithm in the feedback system has important influence on the performance of the beam orbit. PID (Proportion Integration Differentiation) algorithm is widely used in the beam orbit feedback system; however, the deficiency of PID algorithm is a big overshooting in strong perturbations. In order to overcome the deficiencies, the integral-separated PID algorithm is developed. When the closed orbit distortion is too large, it cancels integration action until the closed orbit distortion is lower than the separation threshold value. The implementation of integral-separated PID algorithm with MATLAB is described in this paper. The simulation results show that this algorithm can improve the control precision.

INTRODUCTION

The orbit feedback system can effectively eliminate the closed orbit distortion; a good feedback system can improve remarkably the beam orbit stability. PID algorithm is widely used in the orbit feedback system. In the standard PID feedback, the aim of introduction of the integral action is to eliminate steady-state error and improve control accuracy, but the integral action of PID algorithm will cause big overshooting in strong perturbations. In order to improve the orbit stability, an integral-separated PID algorithm is employed for the orbit feedback control. The basic idea of the integral-separated PID controller is that integral action will be cancelled when there is a big error. The integral action will work when the output value is close to the given value, which will eliminate steady-state error and improve control accuracy.

FEEDBACK THEORY

The beam orbit distortion caused by the change of storage ring state would destroy the stability of the beam orbit. There are many methods to correct the beam closed orbit distortion, but the basic idea of these methods is to eliminate the orbit distortion by using corrector magnet. In order to eliminate the beam orbit distortion, the corrector magnet intensity changes $d\Theta$ should be [1]:

$$d\Theta = R^{-1}dU \quad (1)$$

where dU is the beam orbit distortion, R^{-1} is inverse response matrix, SVD (Singular Value Decomposition)

method can be used to solve R^{-1} .

In order to correct the orbit distortion and improve orbit stability, the integral-separated PID control algorithm will be used. The control algorithm can be expressed as[2]:

$$u(n) = u(n-1) + K_p \left[e(n) + \alpha \frac{T}{T_I} \sum_{j=0}^n e(j) + T_D \frac{e(n) - e(n-1)}{T} \right] \quad (2)$$

$$\alpha = \begin{cases} 1 & |e(n)| \leq \varepsilon \quad \text{PID control} \\ 0 & |e(n)| > \varepsilon \quad \text{PD control} \end{cases}$$

where K_p is named as proportional coefficient, T_I, T_D is named as integral and differential time constant separately, T is sampling interval, n is the sample number, $e(n-1)$ is the error signal for (n-1), $e(n)$ is the error signal for n, $u(n-1)$ is the output of the Integral-separated PID digital controller for (n-1), $u(n)$ is the output of the Integral-separated PID digital controller for n, ε is the artificial separation threshold.

The basic concept of the orbit feedback system is shown in the Figure 1[3][4]. The feedback controller is based on an Integral-separated PID algorithm.

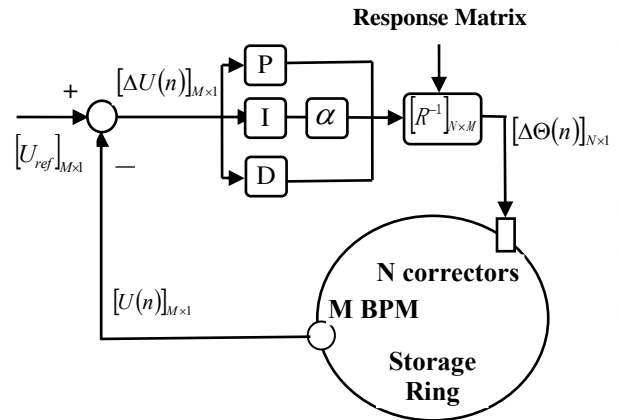

Figure 1: The schematic diagram of the integral-separated PID orbit feedback system.

Where U_{ref} is the reference orbit, $U(n)$ is the BPM value for n, $\Delta U(n)$ is the closed orbit distortion for n, $\Delta \Theta(n)$ is the corrector magnet intensity changes for n.

According to formula (1) and (2), we get the discrete integral-separated PID control formula of beam orbit correction:

* Work supported by National Natural Science Foundation of China (11005114)

[#]xuanke@ustc.edu.cn

$$\Theta(n) = R^{-1}U(n) = R^{-1}U(n-1) + R^{-1}K_p \times \left[\Delta U(n) + \alpha \frac{T}{T_I} \sum_{j=0}^n \Delta U(j) + T_D \frac{\Delta U(n) - \Delta U(n-1)}{T} \right] \quad (3)$$

$$= \Theta(n-1) + K_p \Delta \Theta(n) + \alpha K_I \sum_{j=0}^n \Delta \Theta(j) + K_D [\Delta \Theta(n) - \Delta \Theta(n-1)]$$

where $U(n-1)$ is the BPM value for (n-1), $\Delta U(n-1)$ is the closed orbit distortion for (n-1), $\Theta(n)$ is the corrector magnet intensity for n, $\Theta(n-1)$ is the corrector magnet intensity for (n-1), $\Delta \Theta(n-1)$ is the corrector magnet intensity changes for (n-1), K_I, K_D is named as integral and differential coefficient separately. $K_I = K_p T/T_I$, $K_D = K_p T_D/T$.

ORBIT FEEDBACK SIMULATION

The integral-separation PID feedback algorithm is studied in HLSII storage ring. The storage ring accelerator model is built by AT (Accelerator Toolbox), and the code of the integral-separation PID feedback algorithm is programmed by using MATLAB[5][6].

Concrete steps are introduced as in following:

- (1) Obtain the response matrix by using AT function, and calculate the inverse response matrix R^{-1} .

- (2) Produce orbit distortion by simulating a variety of errors.
- (3) Set separation threshold value and PID parameters according to the actual system.
- (4) Calculate the closed orbit distortion $\Delta U(n)$, if $|\Delta U(n)| > \varepsilon$, Using PD feedback, if $|\Delta U(n)| < \varepsilon$, Using PID feedback.

Repeat 4th step until it reaches the target. Figure 2 shows the flow chart of the integral-separation PID orbit feedback algorithm.

After repeated simulation, the optimal PID control parameters and separation threshold value of the controller module can be determined:

$$K_p = 2, K_I = 0.4, K_D = 0.9, \varepsilon = 0.1mm \quad (4)$$

The effect of orbit feedback by using integral-separation PID algorithm are recorded and shown in figure 3 and figure 4.

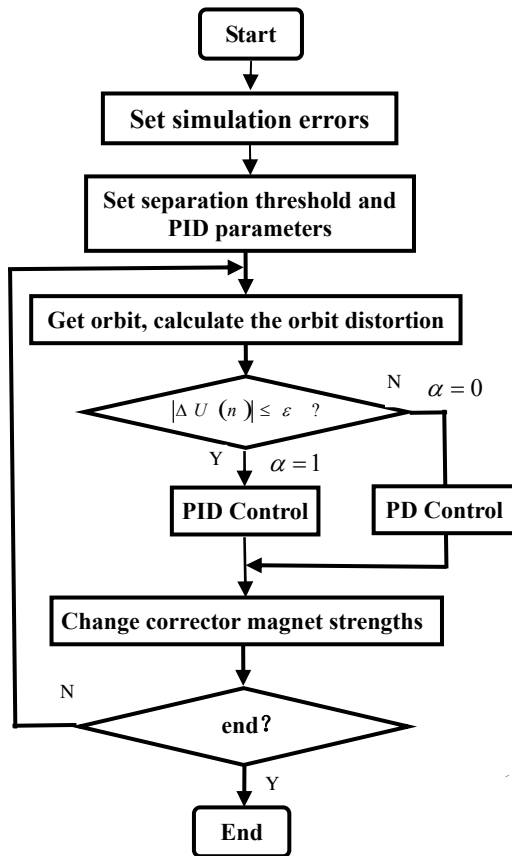

Figure 2: The flow chart of the integral-separation PID orbit feedback algorithm.

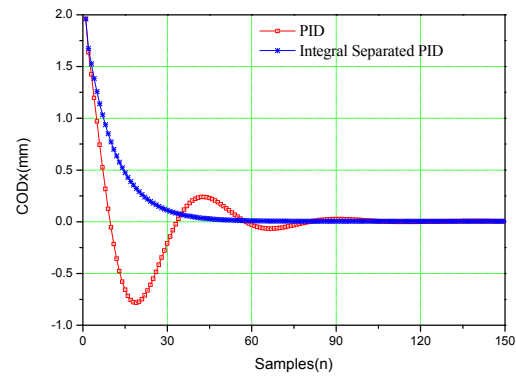

Figure 3: The horizontal orbit of PID control and integral-separation PID at the 16th BPM.

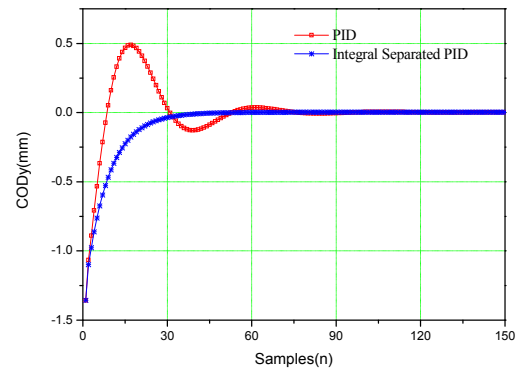

Figure 4: The vertical orbit of PID control and integral-separation PID at the 16th BPM.

Figure 3 and Figure 4 shows the beam orbit stability has been greatly improved after adding integral-separation PID feedback when the orbit distortion is large. After introducing integral action, the proportional coefficient K_p should be adjusted to ensure the stability of the feedback system.

CONCLUSION

The simulation results show the beam orbit feedback based on the integral-separation PID could be smoother and faster than normal PID control, and the control effect has been greatly improved. It is noteworthy that the separation threshold value should be determined according to the specific circumstances and requirements. If the separation threshold is too large, the integral-separation target can not be achieved; if the separation threshold is too small, it will not enter the integration area. If only the PD control, it will not to eliminate steady-state error and improve the beam orbit stability.

REFERENCES

- [1] Li Jingyi, HLS Control System and Physical Research Based on Control System . Hefei: University of Science and Technology of China, p.70-90 (2002) .
- [2] Araki M. PID control, Control Systems, Robotics, and Automation, Vol.II, p.1-23(1995).
- [3] C.H. Kuo, Jenny Chen. "Orbit feedback system for the storage ring of SRRC", ICALEPCS'2001, Nov 2001, WEAP047, p. 373-375 (2001).
- [4] Jeffrey A,Kirchman , Youngsoo Chung, "Experimental Results on the Design for the APS PID Global Orbit Control System" , ICALEPCS'95, Jan. 1995, W-PO-17,(1995).
- [5] Terebilo A. "Accelerator toolbox for MATLAB".SLAC-PUB-8732, (2001).
- [6] Liu Jingkun, "MATLAB simulation of advanced PID control", Beijing: Publishing house of electronics industry, p.27-32 (2011).