

## Control Protocol : The Proposed New CERN Standard Access Procedure to Accelerator Equipment. Status Report

G. Baribaud, I. Barnett, G. Benincasa, O. Berrig, R. Brun, P. Burla, A. Burns, R. Cappi,  
G. Coudert, C. Dehavay, B. Desforges, R. Gavaggio, G. Gelato, H.K. Kuhn, J. Pett, R. Pittin,  
J.P. Royer, E. Schulte, C. Steinbach, P. Strubin, D. Swoboda, N. Trofimov (\*), L. Vos  
CERN European Organisation for Nuclear Research, 1211 Geneva 23, Switzerland  
(\*Home Institute IHEP Institute for High Energy Physics 142284 Protvino, USSR

### Abstract

Control protocol provides a normalized access procedure for equipment of the same kind from a control system. Modelisation and the subsequent identification of functionalities with their parameters, variables and attributes have now been carried out at CERN for representative families of devices.

ISO specifications, such as the ASN.1 metalanguage for data structure representation and MMS definitions and services have, to some extent, been introduced in the design for generality and compatibility with external world. The final product of this design is totally independent of the control systems and permits object oriented implementations in any controls frame. The present paper describes the different phases of the project with a short overview of the various implementations under development at CERN.

### I. INTRODUCTION

Studies on protocols have been carried out at CERN for more than three years. The basic ideas have been set up in the frame of the Technical Board for Controls and Electronics (TEBOCO): this consultative Board had the mandate of investigating and proposing uniformisation and standardization in the concerned field.

The generalities of the control protocol and the results obtained with first prototypes implementations, have been presented at the Accelerator Control Conference in Vancouver, October 1989 [1] [2].

At the beginning of 1990, a working group called WOPRO (Working Group for Protocols, whose members are the Authors of this paper) was set up with the CERN Management mandate of studying and proposing control protocols for all accelerators at CERN.

Studies on Protocols have been carried out by WOPRO through two activities :

i) the different CERN equipments have been grouped in classes of similar devices. For each class, behavioural models have been proposed and the corresponding functionalities with the associated parameters have been identified. Appropriate structures for representing data have also been proposed. This activity, which is independent of the control system layout, has been carried out by the specialists of the WOPRO group.

II) the Control Protocol must be implemented in the actual CERN controls structures. This activity concerns more precisely all those services allowing the external visibility of

the protocol, i.e. the access procedures to the equipment, and the software structures required by the protocol realisation. This implementation study is carried out by controls specialists together with the WOPRO members.

The first and main activity of WOPRO (conceptual design phase) has been terminated by mid 1991 [3] [4] [5] [6]. The second, implementation oriented phase, is under study and major results are expected for spring 1992.

### II. MAIN CHARACTERISTICS OF THE CONTROL PROTOCOL

Standardization and uniformisation of equipment access is not a novelty in accelerator controls field. In fact the control system of each accelerator or Complex has introduced its own standard. What is different in the proposed WOPRO's approach, can be summarized in the following five points :

- The investigations have been carried out CERN wide. Each considered class of devices includes examples coming from the more concerned machines.

- The study has at first been bottom-up oriented, from the equipment to the control system. The proposed protocols fulfill then principally the needs of the users of the control systems at CERN.

- The functional description of the devices includes all aspects related to operation. In the accelerator field a device works very often in close connection with other equipment that is necessary for the accomplishment of its activity (triggering systems, function generators, etc.). The proposed protocols consider these equipment as part of the device and include them in the design.

- The design is based on behavioural models. For each family of the considered devices, the relevant specialists have firstly developed one or several behavioural models: the model includes all aspects that are necessary for an operational use of the device. This conceptualization has provided the degree of abstraction needed for the generality of the design.

- An object oriented approach has been used. The user has to specify "what" to do: the object-device knows "how" to do it. This allows a large independence between the implementations of the controls specialists and those of the device specialists. Other features of the object oriented design, such as class structures, inheritance, etc., are proposed in the implementation phase.

Content from this work may be used under the terms of the CC BY 4.0 licence (© 1992/2024). Any distribution of this work must maintain attribution to the author(s), title of the work, publisher, and DOI

### III. EXPECTED ADVANTAGES OF USING CONTROL PROTOCOLS

One can summarize the positive aspects of control protocols as follows :

- seen from the top (operation), they provide a uniform visibility to the application programs for a class of devices.
- seen from the bottom, the device specialist can totally dedicate his skill to solving his specific problems in the more suitable way.
- as a consequence of the previous point, control protocols promote a better use of competences. Where the controls activities are mixed with the activities of the specific equipment, each party has to learn implementation details of the other party, that are not of his domain of competences. Obviously, this inconvenience is largely reduced with control protocols.
- a clean separation of responsibilities is introduced between controls and equipment specialists. The two independent realizations that communicate with each other only by exchanging well defined messages, permit to fix the position of this ideal "red line" in a natural way at the level of the messages themselves. This is particularly important during fault finding on a system, where the problem of determining which specialist is concerned arises.
- as a consequence, the maintenance of the systems is simplified and facilitated. We recall that the cost in manpower for the maintenance is estimated at about two thirds of the total cost, calculated on the total lifetime of the device.

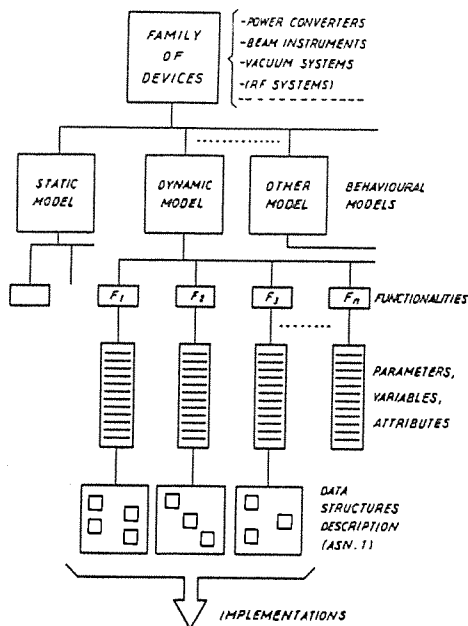

Figure 1. Design phases of control protocol

### IV. CONCEPTUAL DESIGN OF CONTROL PROTOCOLS

As already mentioned in the Introduction, the design phase of the control Protocols has been divided in a sequence of interdependent activities: the output (conclusions) of each activity is used as input (assumptions) for the next one (Figure 1). In order, these activities have been :

#### A. Definition of a Class (Family) of Devices

All those devices with similar characteristics and (or) similar goals, belong to the same class. The first three big classes of devices that we have considered are :

- The Power Converters
- The Beam Instrumentation devices
- The Vacuum systems

#### B. The behavioural models

A model is an abstract representation of the behaviour of an object. In our case the object is a device symbolizing a class of similar devices as previously defined. The control protocols we propose are intended for an operational use of the devices and the specialists have limited their investigations inside this boundary. The result is a serie of models covering all the operational aspects of the concerned families of devices.

#### C. Identification of the Functionalities

In the behavioural models of a class of devices, all those activities that have a common goal in the operational sense can be grouped together to form a Functionality. As an example, five functionalities have been identified in the power converters model :

- Status\_controller
- Settings\_actuator
- Measurements\_actuator
- Trigger\_sequencer
- Function\_generator

#### D. Parameters of the Functionalities

Each single activity inside a given Functionality is accessible by the external world through an appropriate parameter. In general a parameter is composed of variables and attributes. Variables contain the setting values at a given instant. Attributes contain constants representing, in general, the limits of validity for the variables (max. and min. values, lists of discrete values, etc.).

For each Functionality, a complete list of parameters, variables and attributes, has been defined.

#### E. Data structures representation

With the identification and the definition of the parameters and their associated variables and attributes, one can consider

that the first, important phase in the activity of the WOPRO is terminated. This design phase has produced a significant amount of inter-related data : an adequate tool of representing structured data should then be used. We have decided to use the Abstract Syntax Notation One (ASN.1) that is an ISO International Standard (ISO-IEC 8824) fulfilling our needs. ASN.1 uses a metalanguage that permits a simple data representation, totally independent of any specific computer environment : from that, the data structure can be easily translated into a specific source code.

### V. GENERAL IMPLEMENTATION SCHEMES

As already mentioned, the details of implementation are being studied with the control Groups, using their standards and tools. The proposal described here is only a sort of block diagram, representing the basic entities necessary to implement the control protocol (Figure 2). The implementation is composed of two main parts, one specific to each device and one general for a class of devices. They exchange information through the standard defined messages and need data bases to keep relevant data. In more details :

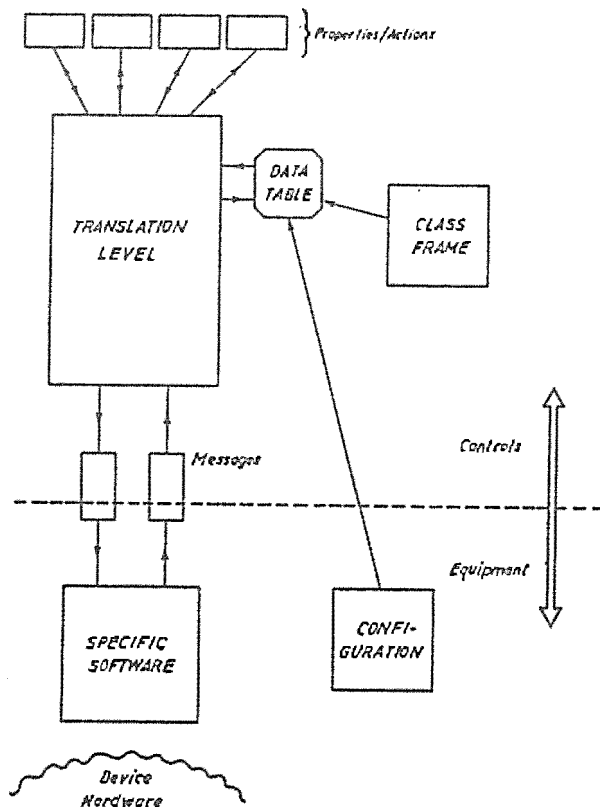

Figure 2. A general implementation scheme

#### A. Definition of Class Frame

The Frame contains a list and a structure definition of all visible functionalities, parameters, variables and attributes for a class of devices. In general the Frame does not contain values; the only exceptions are attributes: each attribute definition is accompanied by a complete, numbered list of all possible values in the process accessed by the control system. The frame should be housed in a central computer data base.

#### B. Definition of Configuration

The configuration contains the list and the values of all functionalities, parameters, variables and attributes for a single, specific device. The form and the structure of these entities are the same as for the class Frame. The configuration should be housed in the device itself and should be extracted using standard services during initialization procedure.

#### C. Definition of Messages

The messages contain the necessary information exchanged between control system and devices. They represent also the red line for separation of responsibilities. Their contents and their logical structure are independent of the controls architecture. Their physical structure depends on the controls features.

The message is composed of a certain number of fields corresponding, at the very most, to the number of Functionalities identified in the corresponding devices class Model. Each field contains a list of the parameters, variables and attributes characteristic for this Functionality, with their associated data.

#### D. Definition of Translation Level

This is a software module that translates the user requests into messages in protocol format. The Translation Level is that part of the control protocol that provides the access services to the equipment (see Introduction). It gives a uniform visibility of all equipment (within a class) to application programs. The implementation of this module strongly depends on the control system features.

### VI. PROTOTYPES UNDER DEVELOPMENT

Three series of prototypes, using CAMAC technology, have already been developed in the PS Complex and are currently in operation. They concern the control of a dozen current beam transformers and their principles have already been reported [2]. These implementations have permitted unambiguous verification of some of the control protocols claimed advantages : in particular the large independence of the controls and specific developments and the software total cost reduction after the first implementation.

A new series of applications is now under development in the new CERN common control system [7]. This series

Content from this work may be used under the terms of the CC BY 4.0 licence (© 1992/2024). Any distribution of this work must maintain attribution to the author(s), title of the work, publisher, and DOI

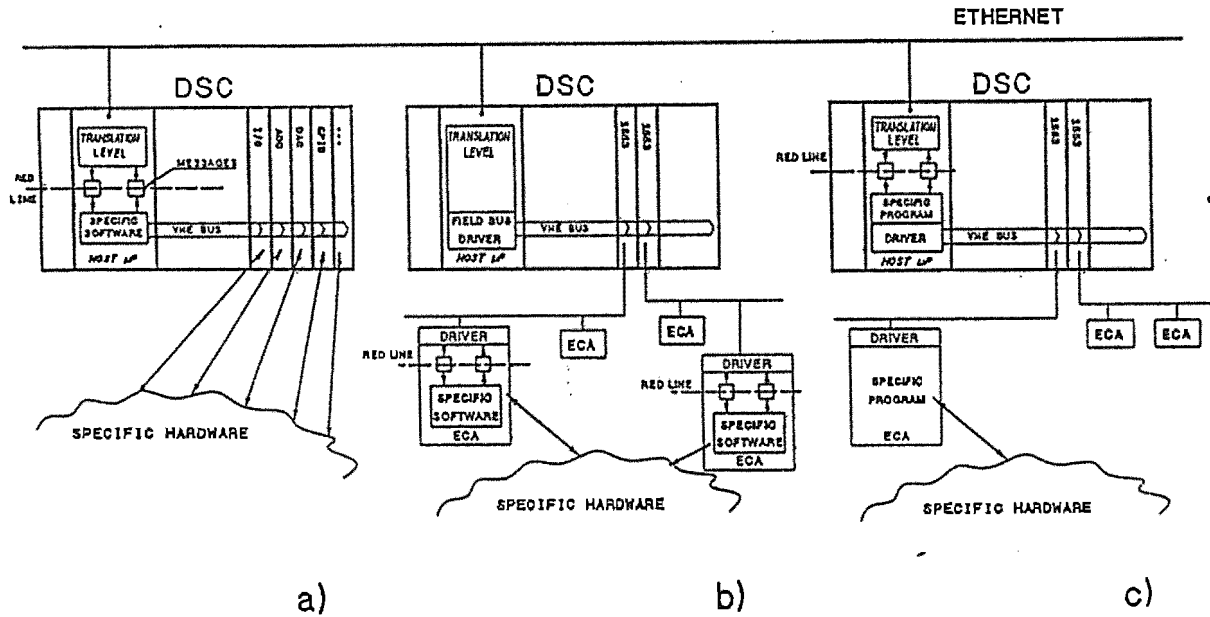

Figure 3. Actual implementation schemes

includes clusters of power converters and different types of beam instrumentation devices : the control protocol is implemented in the front end part of the new control system, called the DSC (Device Stub Controller) a VME crate using a 68030 as main processor and the LYNX RT-UNIX operating system.

Figure 3 presents three possible schemes adapted to different needs of the users, and that we briefly recall :

- Figure 3a represents the case of an equipment having all its I/O modules housed in the DSC : this configuration is more specially, but not exclusively, intended for beam instrumentation devices requiring intricate and complex data treatments. The specific and the control software share the same processor and exchange standard messages.
- In those cases where the equipment is composed of a cluster of similar devices attached to a field bus (power converters), the control protocol could be implemented as in Fig. 3b. The ECA's (Equipment Control Assembly) represent different types of specific crates standards as G64, VME, etc.
- Figure 3c represents a variant of 3b, where the different devices are not totally independent and require, still in the specific software, a common control action.

## VII. REFERENCES

- [1] R. Bailey, G. Baribaud et al. "Operational Protocol for controlling Accelerator Equipment" Int. Conf. on Accelerator Controls, Vancouver, October 89.
- [2] G. Benincasa, L. Casalegno et al. "Implementation of a control protocol in the instrumentation field", Int. Conf. on Accelerator Controls, Vancouver, October 89.
- [3] WOPRO members, reported by G. Benincasa, "Generalities on the operational control protocol", CERN-PS/CO Note 91-01.
- [4] WOPRO members, reported by P. Burla, "Description formelle des paramètres et variables des convertisseurs de puissance pour la définition d'un protocole de contrôle", CERN SL-PC Note 91-86.
- [5] WOPRO members, reported by P. Strubin, "Operational protocol for vacuum systems", CERN AT-VA Note 91-06.
- [6] G. Baribaud, "Operational protocol for timing events", CERN SL-BI Note 90-05.
- [7] The PS and SL Control Groups, "PS/SL controls consolidation project", CERN PS-CO Note 91-09 and SL-CO Note 91-12.