

# Human-Machine Interface Software Package

D.K.Liu C.Z.Zhang  
Institute of High Energy Physics  
P.O.Box 918 Beijing

## Abstract

The Man-Machine Interface software Package(MMISP) is designed to configure the console software of PLS 60Mev LINAC control system [1]. The control system of PLS 60Mev LINAC is a distributed control system which includes the main computer (Intel 310) four local station, and two sets of industrial level console computer. The MMISP provides the operator with the display page editor, various I/O configuration such as digital signals In/Out, analog signal In/Out, waveform TV graphic display, and interactive with operator through graphic picture display, voice explanation, and touch panel. This paper describes its function and application.

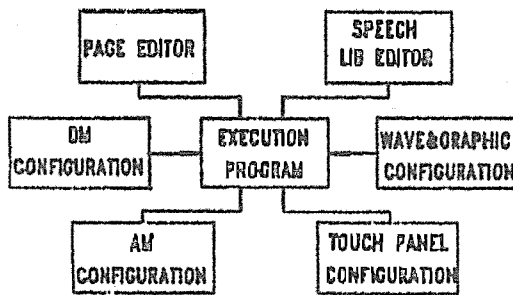

Fig.1 The Structure Diagram of MMISP

## I. INTRODUCTION

Recently, the control level has grown up so fast by VLSI technology development. There are many kind of Workstation developed for interactive tool between operator and computer. Of course it has more powerful function but is also is expensive and can't connect a small system easily. We introduce a interactive software which is highly cost-effective, compact, and emphasizing easy operation based on the PC.

## II. SYSTEM STRUCTURE

The MMISP shown as Fig.1 includes seven subroutines which are the Page Editor, the Speech library Editor, the Digital Monitor(DM) Configuration, the Analog Monitor(AM) Configuration and the Execution Program.

### A. Page Editor

The page editor is used to edit the display picture and to create the drawing library. Its main function is follows:

- \* Drawing the line, circle, block line by cursor or up/down, left/right key
- \* 16 color could be selected
- \* The Picture can be moved, copied and loaded in hard disk as subpicture page

### B. I/O Configuration

1. The DM configuration is used to create the display message of digital signals for the user's page, and the message will be saved in the page setting file. It has 5 kinds of digital display mode, which are the painting given area, the character string display, the drawing element display, the turn to the given page and the speaking something.

2. The AM configuration is applied to generate the display message of analog signals for the user's page, and the message will also be saved in the page setting file. It has six kinds of analog display mode, which are the digital display that the digit number can be selected from 1 to 7, the rectangle or other shape image display, the pointer meter display, and the turn to given page or the speaking something if the analog signal is overvalue.

3. The Wave & Graph Configuration is applied to create the display message of signal waveform, such as pulse voltage wave, or TV image for the user's page, and the message, such as the coordinate and display color etc., will be saved in the page setting file.

4. The Touch Panel Configuration is used to define the function of touch area, and to save these definitions in the page setting file. It has ten functions which are the recovering original color of given area, the changing color of given area, the input and display for a character string or data, the making a character string or data available or

Content from this work may be used under the terms of the CC BY 4.0 licence (© 1992/2024). Any distribution of this work must maintain attribution to the author(s), title of the work, publisher, and DOI

refresh, the adjusting analog signal value by touch panel or encoder, the creating system control command, the entering a submenu, the exiting to a last menu, the turning to a pointed page and the calling user's program, DOS command or speech library.

*C. Speech Program*

This program is designed for explanation of various specification, machine operation such as operation guider. Also it can be used for warning some events such as "High Voltage Current is over, Please pay attention!".

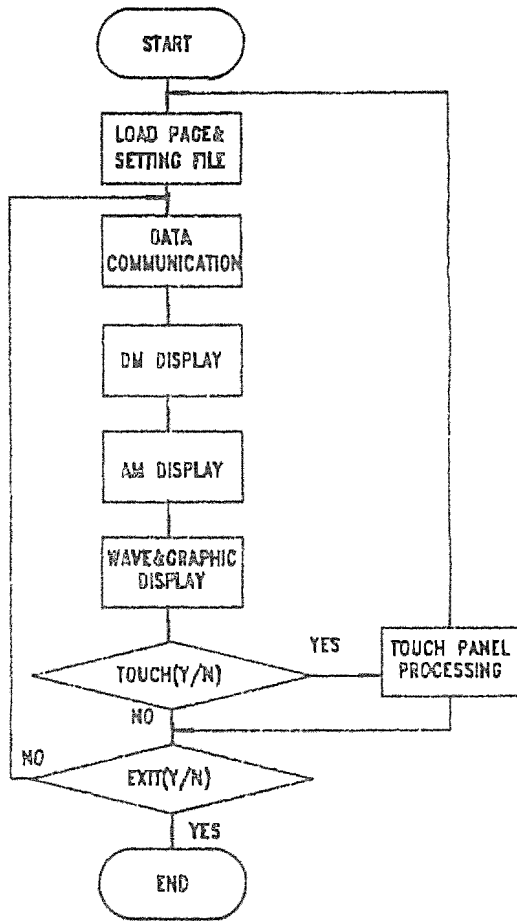

Fig.2 The Flow Chart of Execution Program

*D. The Executive Program*

This program is the core of MMISP. It is of six parts, shown as Fig. 2. These are the load page & setting file, the data communication with the central computer, the DM display, the AM display, the wave & graph display and the touch panel processing. The load page is to display the user's page and to get the configuration information from the page setting file. The data communication is to

acquire the datum of digital signal and analog signal from the database of central computer.

The DM display is to process and display the digital signal according to the user's setting message from setting file. Similarly, the AM display is to process and display the analog signal or TV graph color code signal from the database of central computer, then to process and display at the region which the user defined in the setting file. The touch panel process is to respond to operator's instructions, to make the special treatment according to the user's definition in the setting file, for example, it can turn to the other page, or entry the sub-menu (Each page has 98 submenu, on screen can display 4 submenus at the same time), return to the last menu, and send the control command to central computer etc.

The Executive Program has three running modes, these are Test, Review and On-line Test. At the Test mode, the program generate every kind of data for checking the user's configuration. At the Review mode, the program provides the user to review the previous operation datum; and at On-line Test mode, the program obtains all kind of data from the database of central computer, and refreshes the data display every second.

III. APPLICATION

In general, an accelerator physicist can write the best program to resolve his physics problem as he understands better than software people. Therefore, he must study a long time about system configuration software and then he should understand the data path from controlled equipment to database and console display. But sometime, it is difficult for those specialists or physicists who are not familiar with system configuration software. They wouldn't like to resolve his problem by paying too much time to understand the whole configuration software. Considering this reason, comparing various interactive methods and our experience of accelerator operation, a set of utility interactive tools are used for control system of PLS 80Mev LINAC. The hardware environment of console interface is illustrated in the Fig.3. In the normal case operator can interact in four ways:

- \* Digital command could be through touch panel
- \* Analog control are adjusted by digitalized encoder or touch panel
- \* Various digital signal and parameter of accelerator are shown on the graphic screen.
- \* The voice explanation are used for warning some emergency events to operator.

The major procedure of system configuration using MMISP as following:

1. Picture edit
  - Graphic picture displaying various physical requirements can be edited by PAGE EDITOR easily just as in CAD. At first, designer should make definition of index page and chapters such as dividing modulator-klystron chapter,

Content from this work may be used under the terms of the CC BY 4.0 licence (© 1992/2024). Any distribution of this work must maintain attribution to the author(s), title of the work, publisher, and DOI

beam diagnostics chapter etc. Second, to indicate those region which show parameters and control buttons using PAGE EDITOR.

### 2.Setting I/O signals

Since every signal has its own system signal name, it is easy to point to a position on the designed page. It includes status indicate (DM), status control (DC), analog parameter display and control.(AM and AC)

### 3.Waveform and TV graphic setting

In the normal accelerator control, there are many waveforms such as klystron pulse voltage, pulse current etc. It very easy to configure and record as storage oscilloscope.

4. The function of voice explanation is useful to remind or warn operators to pay attention to accelerator.

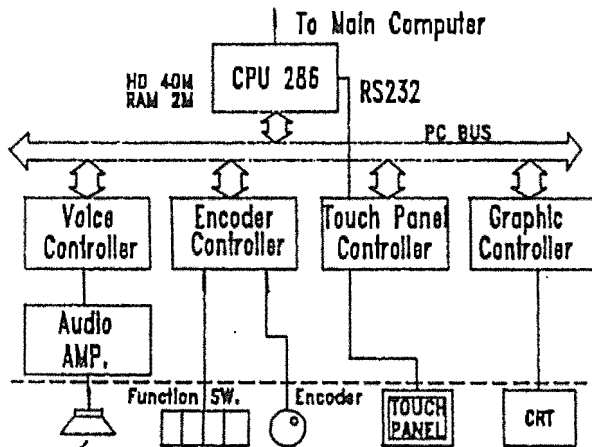

Fig3. Hardware Environment

## IV. CONCLUSION

On other hand, this MMISP could be used in any control system as a movable console which can be linked to computer network using a communication board inserted to PC bus.

Summarized performance of MMISP is follows:

- \* Easy operation as CAD software
- \* Five kind of digital signal display; 150 signals could be used for one page
- \* Six kind of analog signal display; 150 signals could be used for one page
- \* Ten function of touch panel definition; 150 touch region for one page
- \* 10 waveform and 10 graphic display (30K points/1 picture)
- \* 98 sub-pages for one main page
- \* Easy to add new page into edited user system on real-time

## V. REFERENCE

- [1] "Instrumentation & Control System for PLS-IM-T 60Mev LINAC", Contributed to control conference November 1991
- [2] K.Nakahara, I.Abe, K.Furukawa and N.Kamikubota, "An Operator- Console system of the Photon Factory Injector LINAC" Nucl. Instr. and Meth. A293 (1990) 446-449