

## High accuracy ADC and DAC systems for accelerator control applications.

E.Kuper, A.Ledenev  
Institute for Nuclear Physics,  
Novosibirsk, 630090, USSR

### Abstract

In the work presented here the ways of construction, the apparatus for the precision measurements and control systems incorporated in the accelerating facilities of INP are considered. All the apparatus are developed and manufactured in the standard of CAMAC.

### Introduction

While carrying the experiments on the precision measurements of the mezon masses on the installations with the electron - positron colliding beams one has to use the apparatus of a class 0.001% with the resolution about 0.0001%. An instability of the main power supply sources of magnetic systems of storage rings should not exceed 0.002%.

The powerful RF generators, the controlled sources of power supply with an output power of a few hundred kilowatts, pulse components of electron-optical channels, numerous digital devices including computers are the sources of different kinds of noises. Under these conditions, the stronger requirements on the noise damping are posed to the measuring and control equipment and to the analog data transfer lines.

In the power supply system of the facility VEPP-4 one has to measure of about two thousand points and to form the control signals for more than 500 channels. The time of energy rise is of a few tens of seconds. In the mode of operation one needs the high accuracy matching (0.1% - 0.01%) in the field variation in the magnetic components of accelerators. The technical parameters of the control and measuring structures should provide the operation of the power supply systems both in the static and in dynamic modes of operation.

### Digital - to - analog converters

Usually, the power supply sources of the storage ring facilities requires the digital-to-analog converters (DAC) of quite a low fast action at an accuracy ranging from 0.1% up to 0.001%. Therefore, most of the converters used are designed on the base of the pulse width modulation PWM. The advantages of the given type of DAC are well known: the minimum

of precise components at a practically arbitrary resolution, high linearity, easily achieved the galvanic isolation of the analog part and consequently, a low price.

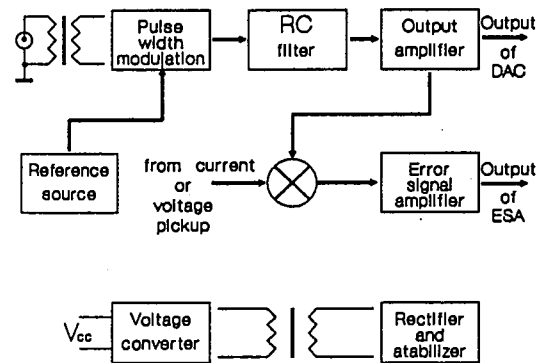

Fig.1. The analog section of PWM-DAC.

One of the popular developments of INP is an 8-channel code-to-duty factor converter (CDFC) located in the crate and transferring the control signal to DAC - PWM integrated directly to the control objects. The DAC signals in the form of different polarity pulse, the distance between carrying the data on, reference voltage for control system are transferred through the coaxial cable with the transformer de-coupling to the distance of up to 500 m. The simplified schematic diagram of the converter is given in Fig.1. The pulsed signals from DAC arrive at the trigger controlled by the analog switches. The PWM modulated signal is filtered with the RC filter of the 3rd order. In order to match it with the control system the error signal amplifier (ESA) is envisaged which equalizer the DAC output signal to that from the current or voltage sensor. The galvanic de-coupling on power supply is performed with the help of high frequency converter with the transformer of special design with the minimum crossing capacitance. DAC parameters are: 16 bites, error - 0.01%, settling time - 0.4 s, temperature factor of the output voltage - 0.0003%/K. The given configuration is being widely used in the systems of pulse power supply of the transport channels for charged particles, in the power supply sources for the "high current" correctors, i.e. in those cases, where the controlled objects are distanced considerably and their groundings are

Content from this work may be used under the terms of the CC BY 4.0 licence (© 1992/2024). Any distribution of this work must maintain attribution to the author(s), title of the work, publisher, and DOI

explicitly non-equipotential.

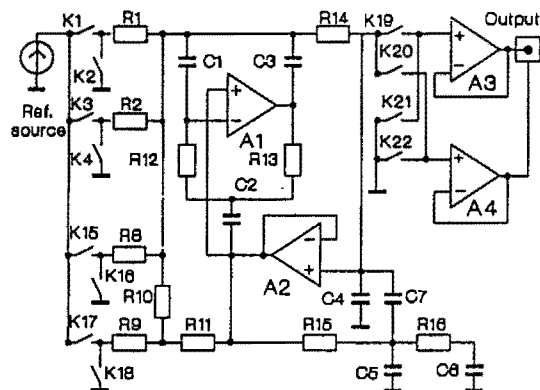

Fig.2. The analog section of multiphase PWM-DAC.

For the problems with higher requirements to the control accuracy (power supply systems of the main magnets and lenses of storage rings) the precision DAC was developed that is based on the use of the multiphase pulse-width modulation. This method is the improved version of the PWM. Its use enables one to reduce the settling time by a factor of the number of phases with respect to the conventional case and similarly to reduce the switching frequency. In this case, the requirements to the fast switching time of the analog switches determining the PWM signal became weaker. This fact enables one to simplify substantially the technical-design solutions of the switches and drivers using the standard logic elements of CMOS kind. The schematic diagram of the analog part of the apparatus is given in Fig.2. DAC is performed according to the two-cascade circuit. The output voltage is the sum (with weights  $1/2048$ ) of voltages of two independent DACs. The first one converts 11 senior bits and has an 8-phase generation of the output signal (switches K1 - K16). The second DAC for junior bits is a single-phase, 8-bit (K17 - K18). The voltages of both the DACs are summed by the resistors and smoothed by one filter of low frequency (A1, A2). The bipolar voltage is produced by the output circuit (K19 - K22, A3, A4). In the source of output voltage the precision reference diode is employed in the oven with the stability of temperature 1K.

The apparatus has the following parameters:

scale length	20 bits
voltage range	8,192 V
quantization step	15,625 $\mu$ V
error (for 3 months)	0.001%
nonlinearity	0.0001%
temperature factor of output voltage	0.00002%/K +2 $\mu$ V/K

settling time with error 0.001% 0.1 s  
 analog part capacity with respect to the body 150 pF  
 module width 1 M

In the process of energy retuning of the storage ring of charge particles the matched variation of parameters is required for many power supply sources of magnetic elements with its high accuracy and highly synchronous. In the power supply systems of first generation this problem was solved by the appropriate selection (taking into account the individual characteristics of magnets) of special RC-filters on the DAC output. At present, the most relevant solution of the problem given is the use of DAC with the built-in digital interpolators. Two types of converters have been developed.

The multichannel DAC provides the conversion of a 16 bits code with the error 0.01% over 16 channels. The built-in processor makes the simultaneous variation of the output voltages. The variation law for each channel is given with the intermediate values by which the portion-linear interpolation is performed. Up to 80 intermediate values can be given for each channel. In addition, in each linear part the interpolation time is given within the range from 1 to 63 s with the quantization step of 1 s or in the range from 0.1 to 6.3 s with the quantization step of 0.1 s.

For the control of the precision channel a 20 bit DAC was developed with the built-in signal error amplifier. The conversion error is 0.001%. The functions of the digital interpolator are similar to that described above.

The converter control is performed through the controller with the protocol MIL-STD 1553B. The controller is designed in the CAMAC standard.

#### Apparatus for measurements of direct voltages

As already mentioned, the real operation of any large physical facility is usually accompanied by the generation of a large wide range of very different electromagnetic noises and quite often the amplitude of these noises is substantially higher than the signal to be measured. Therefore, in the analog-to-digital converters the most noise-resistant method of preliminary integration of the output signal is used.

Using various modifications of the method: the dual-slop integration, multi-tact integration, the method of dynamic integration, the series of ADCs is designed at INP aimed at the use in the multichannel noise-resistance measuring systems. Let us consider briefly the features of construction and parameters of the most characteristic versions of this series.

Content from this work may be used under the terms of the CC BY 4.0 licence (© 1992/2024). Any distribution of this work must maintain attribution to the author(s), title of the work, publisher, and DOI

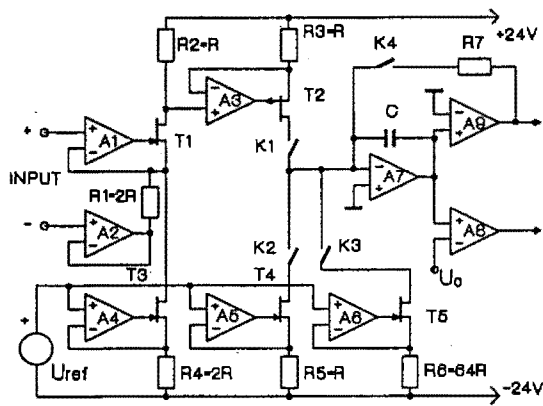

Fig.3. Three-step integrating ADC.

The three-step integration with respect to the dual-slop one enables the reduction of the error that is due to the noises of the integrator amplifier and comparator. An additional advantage of the method is its high resolution at comparatively low frequency of the tact generator. The simplified block diagram of the device is given in Fig.3. The input signal with the help of amplifiers A1 and A2 is converted into a current. A3, T2 is the current mirror. To achieve the fast action the switches K1 - K3 are made with diodes. The main reference signal is generated by the current generator on A5, T4. The reference signal of the third step 64 times lowered is formed with A6, T5. During the first step the integration of the input signal is performed. During the subsequent two steps the integration of the main and divided reference signals is performed. This method is realized on the ADC 15 - 256. Its main parameters are given in Tab.1. The device has a built-in memory for 256 words and the control circuit for the analog multiplexer that transfers the address of the measured channel in the subsequent code through the socket on the front panel. While performing the multichannel measurements the operation is performed in the following way: preliminary to the service register of ADC the initial and final addresses of channels are written along which the measurements should be performed. By the start command ADC performs the given series of measurements and writes the results into the corresponding cell of the built-in storage. The presence of this given mode enables one to reduce substantially the load of the CAMAC data bus in the measurement system.

The method of multistep integration enables one to reach the high resolution and linearity of the converter at quite high fast action. The block diagram of the method performance is given in Fig.4. Its essence is the following. Simultaneously with the input signal integration the reference signal is

integrated by a certain algorithm. When the integrator output voltage reaches its threshold value (either A2 or A4 comparator is operated) to the integrator input the reference voltage is applied whose polarity is opposite to the input voltage for the fixed period of time, i.e. the multi-step integration of the reference and input signals is performed. After input signal integration the operation algorithm is the same as that in the previous method. The end of the 3rd step, during which the reduced reference voltage is integrated, is defined by the comparator A3. In this scheme the integrator transfer factor is approximately the same as the number of integration steps when measuring the input maximum signal.

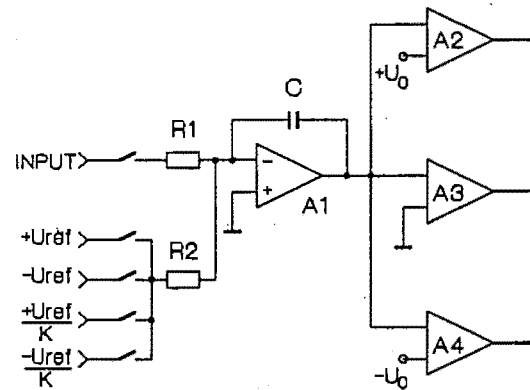

Fig.4. ADC with multicycle integration.

Note that conversion errors related to the polarization of integrator capacitor dielectric are reduced similarly. On the base of this method the precision converter ADC-22 was designed (Table 1). Let us give some additional characteristics of the device that are important for the construction of measuring systems of high accuracy: integration time of the input signal - 20 ms; settling time for the input amplifier (with an error 0.001% - 8 ms; signal measurement range 0.1; 1; 10; 100; 1000 V; resolution capability, respectively, 0.1; 1; 10; 100; 1000 μV; relative error of conversion in the range of 10 V for 8 hours - 0.0005% of the scale, an additional temperature error - 0.00005%/K; temperature drift of voltage - 0.03 μV/K; input current - lower than 10 pA; the input resistance on lower ranges - higher than 100 GOhm.

The method of dynamic integrator. This method is the version of the pulse width modulation PWM conversion with the pulse feed back. The block diagram of the dynamic integrator operation is given in Fig.5. The input signal is applied to the input of integrator A1 through resistor R2. Depending on the integrator input voltage polarity, defined by the comparator A2, an appropriate reference voltage is

applied to the integrator input through the switches K1 and K2. (The operation of these switches is synchronized with the switching frequency by the D-trigger.) The specific feature of the method is that simultaneously with the input and reference signals through the capacitor C2 to the integrator input the periodic voltage is applied of the rectangular shape whose amplitude exceeds the sum of modules of the input and reference voltages. The main advantage of the method is that it enables one to vary the time and bits of conversion. This property is especially useful for ADC designed for the multichannel measurements: measurements with not very high accuracy are performed quickly but those of high accuracy - slower but with larger number of bits. With larger time of measurement an additional filtering is envisaged for high frequency noises in the measured signals.

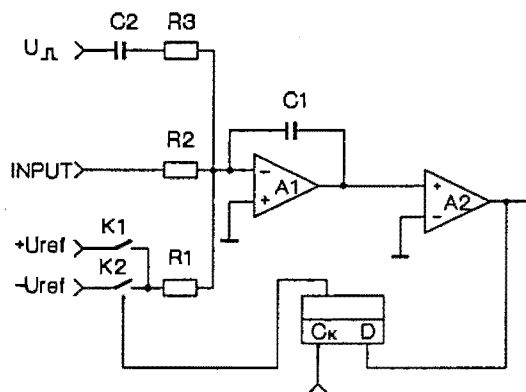

Fig.5. ADC with dynamic-integrator.

On the base of the method of dynamic integrator ADC-20 and ADC-20-256 (Table 1) are designed. Each of these modules has 8 time ranges of measurements (when switching the ranges the scale length changes respectively) and 2 ranges for the input signals (8 V and 500 mV) which enables the measurement of voltage in the microvolt range. ADC-20-256 has a built-in memory and the control for the multiplexer.

Table 1

Type of device	ADC22	ADC20	ADC20-256	ADC15-256
Conversion time, ms	40	7.5-480	1.25-160	0.1
Scale (binary)	22	14-20	13-20	15
Error (for 3 months)	0.001%	0.01%	0.01%	0.01%
Memory (words)	-	-	256	256
Common mode rejection, db	140	120	120	80

The metrological characteristics of devices remain the same within the range 20 K - 50 K.

For the arrangements of the multichannel measuring systems some analog multiplexers been developed at the Institute:

- AM-16R and AM-128R: with 16 and 64 channels respectively, the commutation elements - sealed contact reed relay with switching time of 1 ms, maximum voltage - 200 V, commutation error - 50  $\mu$ V.
- AM-16RM and AM-32R: with 16 and 32 channels respectively, the commutation elements - thermocompensated reed-relays, commutation error - 1  $\mu$ V. They are designed for the measuring systems in the microvolt range.
- AM-128: 64 channels, produced based on microcircuits with the complementary MOS-transistors, switching time - 10  $\mu$ s, input voltage range - 10 V, commutation error - 100  $\mu$ V.

The multiplexing of input signals is usually performed according to the two wire circuit.

In all the versions the protection is envisaged against the overvoltages by the input. The address register of multiplexers have 8 bits, that enables the union of up to 256 measuring channels per one converter.