

The Development of RF Reference Lines and a Timing System  
 for Japan Linear Collider

J.Urakawa, T.Kawamoto, Y.Otake, Y.Satoh,  
 T.Mimashi and S.Araki

National Laboratory for High Energy Physics(KEK),  
 Oho 1-1, Tsukuba-shi, Ibaraki-ken, 305 Japan

Abstract

The main linac of Japan Linear Collider(JLC) will be operated at an X-band frequency of 11.424GHz. The positioning of the X-band accelerating structures at JLC requires precise phase synchronisation over about 10km. Temperature compensated fiber optic cables will be used for the transmission of the 11.424GHz RF signal. The performance of this transmission line is described. Many timing signals will be also transmitted from the main control room, in which the master RF frequency generator will be situated, via this 1.3 $\mu$ m single mode fiber optic link. The outline of the timing system for JLC is given in this paper.

I. INTRODUCTION

A. General

Japan Linear Collider(JLC) is a future project and an electron-positron collider for the energy frontier physics in TeV region. In order to realize the JLC project, we have been discussing for several years on possible parameter sets of the JLC. Fig.1 shows the layout of the JLC according to the parameter set so far obtained[1,2,3].

The main beam parameters of the JLC are shown in Table 1. One of the characteristics of the present design of the JLC is to operate in a multi-bunch mode. The linac accelerates bunch trains where the bunches contained in a train are separated by about 42cm(1.4nsec) and the number of particles per bunch is  $2 \times 10^{10}$ . Fig.2 shows the bunch structure of the JLC.

Table 1 Design Parameters of the JLC

Center of Mass Energy	E[TeV]	0.5	1	1.5
Luminosity	L[cm <sup>-2</sup> sec <sup>-1</sup> ]	2.2x10 <sup>31</sup>	8.8x10 <sup>31</sup>	1.3x10 <sup>32</sup>
Total Length of JLC	L[km]	25	25	25
RF Frequency	f <sub>rf</sub> [GHz]	11.424	11.424	11.424
Accelerating Gradient	G <sub>0</sub> [MeV/m]	40	80	120
Repetition Frequency	f <sub>rep</sub> [Hz]	150	150	150
Particles/Bunch	N	1.3x10 <sup>10</sup>	2.0x10 <sup>10</sup>	2.7x10 <sup>10</sup>
Bunches/RF Pulse	N <sub>b</sub>	20	20	20
Wall Plug Power	P <sub>ac</sub> [MW]	30	120	240
Average Beam Power	P <sub>b</sub> [MW]	3.0	9.7	19.3
Horizontal Normalized Emittance	$\epsilon_{x,n}$ [radm]	5x10 <sup>-6</sup>	5x10 <sup>-6</sup>	5x10 <sup>-6</sup>
Vertical Normalized Emittance	$\epsilon_{y,n}$ [radm]	5x10 <sup>-8</sup>	5x10 <sup>-8</sup>	5x10 <sup>-8</sup>
Beam Size at IP	$\sigma_x/\sigma_y$ [nm]	4.6/335	3.2/372	2.9/560
R.M.S. Bunch Length	$\sigma_z$ [ $\mu$ m]	152	112	95
Energy Loss by Beamstrahlung	$\Delta E/E$ (%)	5.1	15	15
Circumference of Pre-DR	L <sub>pre</sub> [m]	60.1	60.1	60.1
Circumference of Main-DR	L <sub>main</sub> [m]	163.3	163.3	163.3

The JLC timing system is divided into fast and slow timing systems. Fast timing signal transmission system must achieve the timing accuracy within 1psec over the temperature range from 23 to 27°C and over 12.5km from the main control room. For the precise timing signal transmission, a optical fiber cable was developed[4]. This fiber cable showed the reduced thermal transmission delay change less than 10psec/km in the temperature range from -20 to 30°C(average 0.04ppm/°C), which is 100 times smaller than that of any other existing coaxial cables and conventional optical

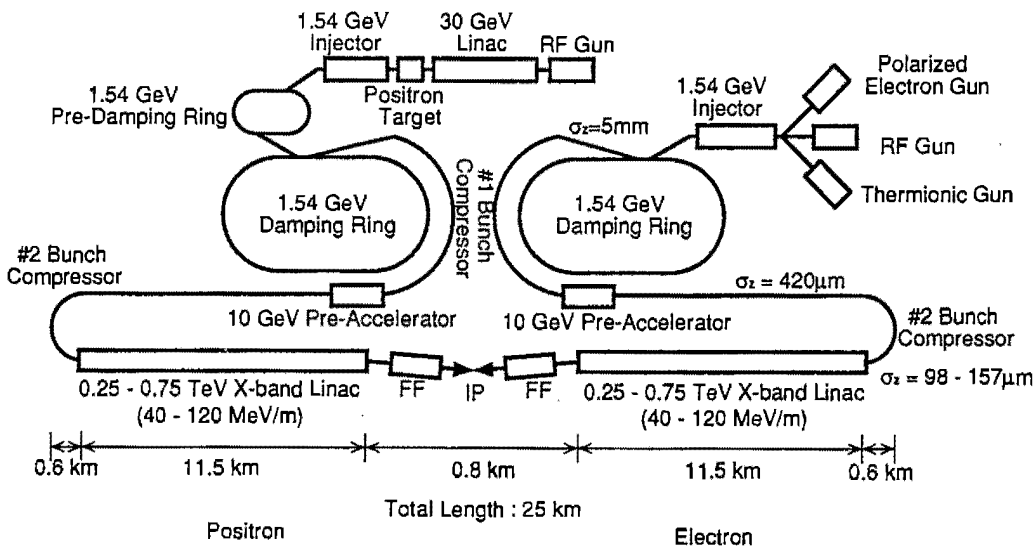

Fig. 1 Layout of the JLC

Content from this work may be used under the terms of the CC BY 4.0 licence (© 1992/2024). Any distribution of this work must maintain attribution to the author(s), title of the work, publisher, and DOI

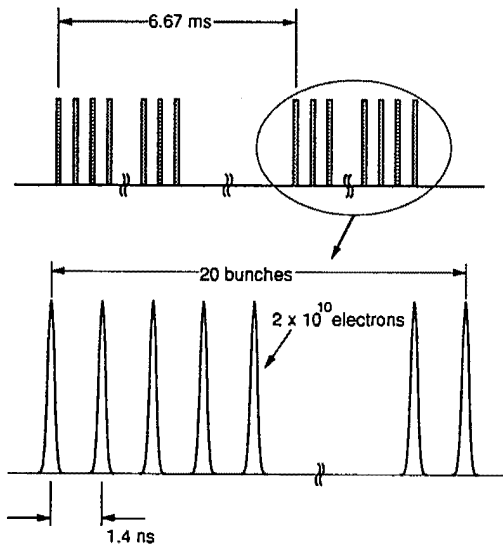

Fig.2 Beam Structure of the JLC

fiber cables. The new optical fiber cable will be installed on a cable rack in the tunnel, in which many klystrons and modulators will be set. In the slow timing system, a dedicated microprocessor for the generation of slow timing signals will be introduced in the computer network system for the JLC control[5]. The slow timing signals will be also transmitted through other fiber in the cable which contains many fibers in it. This communication line is necessary for changing the operation mode and for monitoring synchronized with the beam pulse on a pulse-to-pulse basis.

The fast timing system supplies timing signals(fast timing) for devices whose operation is synchronized with bunched beams. These signals are also used in various beam monitors and beam feedback systems. The slow timing system generates trigger signals(slow timing) in order to achieve synchronization between the beam and the computer processing. These triggers are also used for the automatic operation of machines. The slow timing system manages the operation mode of machines with both flexibility and extensibility. The synchronization signals are transmitted through optical fiber cables over 12.5km from the main control room.

In this paper we describe results and status of the research and development for the RF reference lines. Also, the conceptual design of the fast timing system is described since the outline of the slow timing system was shown in other paper[5,6].

### B. Requirements

The beam control and instrumentation of the JLC requires very high precise RF reference lines and timing system. Following requirements are mainly thought to be necessary.

1. The jitter requirements for the gun trigger is determined by the stability of number of particles per bunch ( $\pm 0.5\%$ ) and the energy acceptance of the electron damping ring ( $\pm 0.7\%$ ). We must reduce the beam timing jitter to less than  $\sim 5$ psec (rms) with the enough accuracy of electron gun trigger.
2. The phase stability of the RF system for the rings must be reduced to less than  $\pm 0.1$  degree (rms) because this value determines collision point in the interaction region.
3. The energy spread of the beam in the main linac must be decreased to less than  $\pm 0.1\%$  (rms) because the energy acceptance in final focus system is small. Then, the signal accuracy of X-band

reference line must be reduced to less than  $\sim 1$ psec (rms). We maybe also introduce two kinds of structures with a little different accelerating frequency as the tool for the compensation of energy gain variation due to beam loading[7].

4. Since beam instrumentation and control on a bunch-to-bunch basis or on a pulse-to-pulse (train-to-train) basis are essentially required, we must make precise beam timing signals at any local place over 12.5km from the main control room.

## II. RESULTS OF THE RESEARCH AND DEVELOPMENT FOR THE RF REFERENCE LINES

### A. The Optical Fiber Cable

The thermal coefficient for transmission delay is negligible around  $20^\circ\text{C}$ . This optical fiber has the following characteristics:

- (1) Stable transmission delay time (less than  $0.04\text{ppm}/^\circ\text{C}$ ),
- (2) Low loss ( $0.35\text{dB}/\text{km}$ ),
- (3) Immunity to electro-magnetic interference,
- (4) High resistance against radiation.

Even in the whole expected operation range  $-20$  to  $+30^\circ\text{C}$ , the transmission delay change is only within  $10\text{ps}/\text{km}$ . These values are far better than any other existing cables. Fig.3 shows the measured transmission delay time change against temperature for the fiber cable. For the comparison, typical data for the conventional fiber is also shown in Fig.3[8].

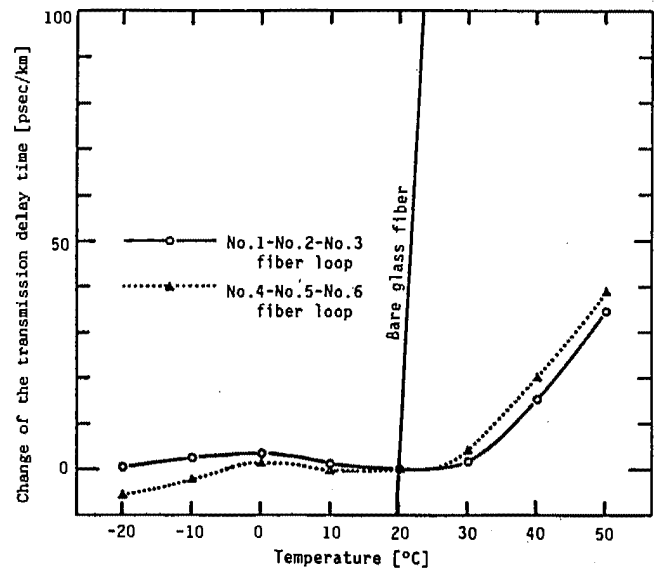

Fig.3 Temperature dependence of the transmission delay time

This fiber cable was installed from the gun room of LINAC to the main control room of the TRISTAN AR in April 1989. The cable has 800m length and contains 6 fibers in it. 300 meter of the total cable was laid even in the underground Positron Beam Transfer Line where the cable was subjected to the irradiation. Since the core material of this fiber is pure silica, this fiber cable is much resistant to irradiation than conventional fiber cables. The characteristics has not been degraded during the last two years.

The confirmed high stability suggests that the use of this cable system will effectively simplify and improve the "main drive lines" in the acceleration systems, where large diameter coaxial cables are used in the special conduit with sophisticated temperature control.

Content from this work may be used under the terms of the CC BY 4.0 licence (© 1992/2024). Any distribution of this work must maintain attribution to the author(s), title of the work, publisher, and DOI

**B. Test Results**

For the further characterization of the system, the two experiments were conducted. Two other fibers in the cable were connected together at the gun room so that they made a 1600m link with both input and output ends locating at the control room. Using this 1600m link with measuring setup shown in Fig.4 and Fig.5, jitter of the 508MHz signal and drift of the 11.424GHz signal were evaluated.

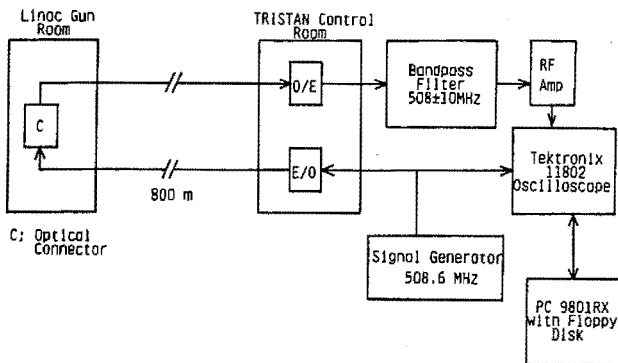

Fig.4 The Circuit for the Measurement of the Timing Accuracy

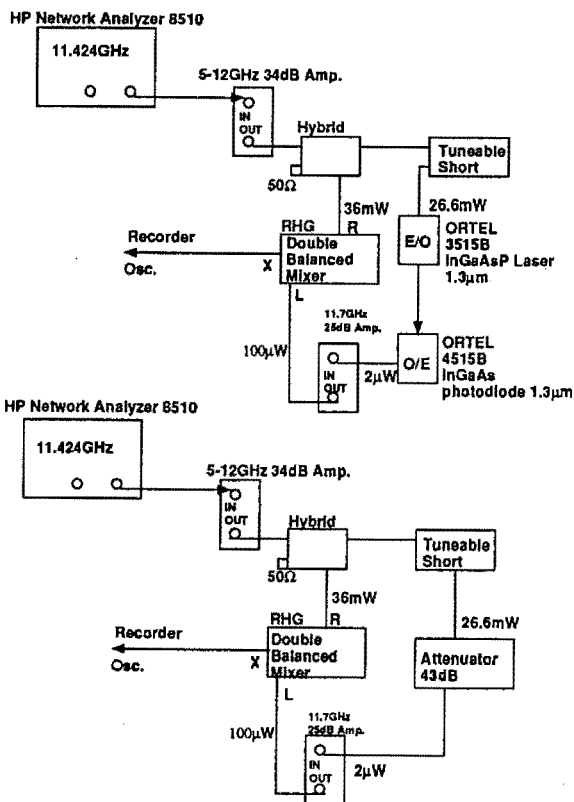

Fig.5 The Circuit for the Measurement of the Phase Accuracy

Phase jitter was measured by a Tektronix 11802 Oscilloscope, and recorded every 40 seconds for 24 hours to evaluate the long-term drift. The long-term drift over the 1600m link transmission was almost negligibly small(Fig.6). Detail report of this jitter measurement was given in other paper[8].

Fig.7 shows the drift of the 11.424GHz signal with fiberoptic devices from Ortel Corporation and without them. The temperature in the experimental room changed in the range of 23.1 to

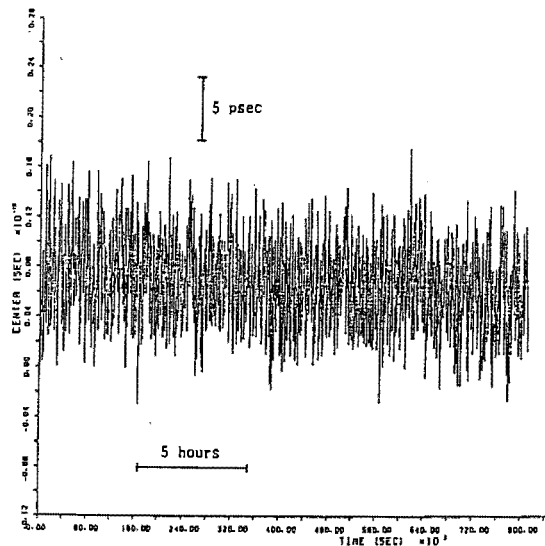

Fig.6 Jitter Fluctuation over 24 Hours

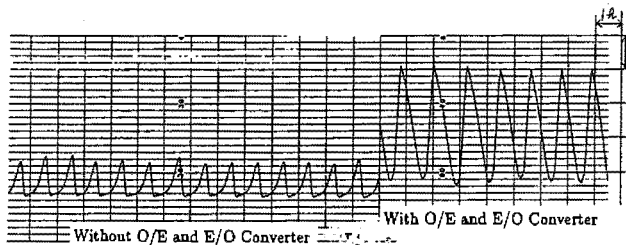

Fig.7 Phase Drift of the 11.424GHz Signal. Horizontal scale; 1hour/div., Vertical scale; 2 degrees/div., 2 degrees correspond to about 0.5psec.

25.5°C due to air conditioner. 4 degrees correspond to the phase drift of 1.0psec for 11.424GHz RF signal. Since the double balanced mixer of RHG can respond until 1GHz, we observed that the phase jitter within the bandwidth of 1GHz was almost small. The complete measurement of the phase jitter is in progress.

**III. CONCEPTUAL DESIGN OF THE FAST TIMING SYSTEM**

Many devices for linear collider research and development require precise timing signals. The fast timing system provides timing signals for the pulsed operation of the gun, bunchers, klystron modulators and other equipment. Depending upon the operation mode, several parameters in the timing system must be controlled. A line synchronization generator in the fast timing system is designed to provide triggers(150Hz) at a fixed phase of the three-phase AC line frequency to reduce power line AC effects in accelerator operation. The timing accuracy of this generator is better than ~10nsec(rms). The 150Hz zero crossing signals are synchronized with the 714MHz by a beam timing delay module.

At first, the synchronizer generates a pre-trigger pulse for the S-band linac, the damping ring and the X-band linac. Then the main delay trigger module generates the source of the gun trigger pulse by delaying the pre-trigger. Fig.8 shows the conceptual

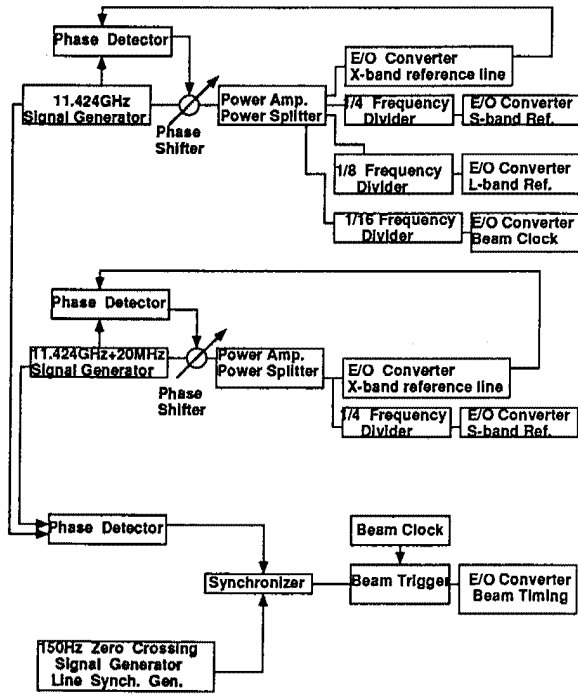

Fig.8 Conceptual Design of the Timing System for JLC

design for timing system which is intended to develop as RF reference lines and beam timing transmission lines for the JLC.

#### IV. STATUS OF THE RESEARCH AND DEVELOPMENT

The KEK Accelerator Test Facility(KEK-ATF) for the JLC is in construction. The ATF consists of the following major accelerator components; 1.54GeV S-band injector, damping ring, bunch compressor, final focus test facility, 0.5GeV X-band linac and a test station for positron production[9]. Since the S-band injector linac will be completed until March of 1993, following low level modules are being developed for the timing signal transmission system by using GaAs integrated circuits from Nippon Electric Corporation(NEC).

1.  $\mu$ PG506B;11.424GHz 1/8 dynamic prescaler
2.  $\mu$ PG501B;2.856GHz 1/4 dynamic prescaler
3.  $\mu$ PG502B;2.856GHz 1/2 dynamic prescaler
4.  $\mu$ PB587G;0.05GHz-1GHz 1/2, 1/4, 1/8 prescaler
5. Low level power amplifiers
6. Phase shifter
7. Fast phase switch, etc.

In order to investigate the characteristic of materials for RF circuit board, we are designing above frequency divider circuits on three kinds of board. We will decide the material until April of 1992 and complete the timing system for the S-band injector until end of 1992.

We have transmitted 11.424GHz reference signal over 1.6km and obtained enough phase stability. The measurement of the jitter was only shown in the case of 508.6MHz transmission. We are planning to measure the jitter in the case of 11.424GHz transmission. The developments for low level control circuits, especially RF frequency dividers, are in progress.

#### V. ACKNOWLEDGEMENTS

The authors would like to thank Professors Y.Kimura, Shigeru Takeda and Seishi Takeda for their support during the work. They also wish to thank Dr. S.Tanaka and Mr. Y.Murakami of SUMITOMO Electric Industries for the collaboration in the construction and the test of the optical fiber transmission system.

#### VI. REFERENCES

- [1] Y.Kimura, Proc. of the 2nd European Particle Accelerator Conference, Nice, France, June 12-16, 1990, pp.23.
- [2] K.Takata, Proc. of 1990 Linear Accelerator Conference, Albuquerque, New Mexico, Sep. 10-14, 1990, pp.13.
- [3] S.Takeda, Particle Accelerators, Vol.30 (1990) pp.143.
- [4] J.Urakawa, Particle Accelerators, Vol.29 (1990) pp.251.
- [5] J.Urakawa et al., Nucl. Instr. and Meth. A293 (1990) pp.206.
- [6] J.Urakawa et al., Nucl. Instr. and Meth. A293 (1990) pp.23.
- [7] T.Higo, Private Communication
- [8] S.Tanaka et al., KEK Report 90-5 (1990)
- [9] Proceedings of the Second Workshop on Japan Linear Collider(JLC), KEK, 1990, KEK Proceedings 91-10(1991)