

Present Status of the JT-60 Control System

T. Kimura

Naka Fusion Research Establishment
Japan Atomic Energy Research Institute
801-1 Mukohyama, Naka-machi, Naka-gun, Ibaraki-ken 311-01 Japan

Abstract

The present status of the control system for a large fusion device of the JT-60 upgrade tokamak is reported including its original design concept, the progress of the system in the past five-year operation and modification for the upgrade. The control system has the features of hierarchical structure, computer control, adoption of CAMAC interfaces and protective interlock by both software and hard-wired systems. Plant monitoring and control are performed by an efficient data communication via CAMAC highways. Sequential discharge control of is executed by a combination of computers and a timing system. A plasma feedback control system with fast 32-bit microprocessors and a man/machine interface with modern workstations have been newly developed for the operation of the JT-60 upgrade.

1. INTRODUCTION

The JT-60 tokamak is a large scale fusion experimental device for the study of magnetically confined plasmas near the thermal break-even condition. Since the first plasma obtained in April 1985, studies on impurity and particle control, confinement of high-power heated plasmas and steady state operation by radio-frequency wave current drive and production of the bootstrap current discharges were performed. The JT-60 tokamak has been upgraded in order to push forward these fusion researches conducted in the past five-year operation [1]. In the JT-60 upgrade (JT-60U) we can perform deuterium discharges with plasma current up to 6 MA and additional heating power of 50 MW. Throughout these investigations we intend to obtain physical and technological databases for the next-step machines.

This paper reports the present status of the JT-60 control system including its original design concepts, progress of the system in the past five-year operation and modification for the upgrade.

2. REQUIREMENTS AND DESIGN PHILOSOPHY

Since the JT-60 tokamak is a large-scale device with respect to the number of components, their occupied space, the amount of electric power consumption, etc. Since intrinsically unstable plasmas are produced and maintained, the control system is required to have high reliability and high speed. Besides these features it has to possess the characteristics of flexibility, expansibility and safety. Hence, the JT-60 control system was designed and fabricated with the following

features [2]:

(1) Hierarchical structure

JT-60U consists of more than ten subsystems such as a vacuum pumping system, magnet power supplies and plasma heating apparatus. These subsystems have to be separately operated in their preparatory stages before plasma operation. Moreover, they have to be organized into one system to perform plasma operation. Hence, the JT-60 control system has hierarchical structure of its central control system named ZENKEI and subsystem controllers.

(2) Computer control

Computer control was introduced for the operation of the JT-60 tokamak. Eight minicomputers and about a hundred microcomputers are used for a wide variety of control functions from fast feedback control of plasma discharge to handling of a large amount of monitoring and control data. In addition to 16-bit computers in the original control system, advanced 32-bit microprocessors and workstations have been newly introduced in the control system.

(3) CAMAC interfaces

Since fabrication for each subsystem was contracted to industry separately, various kinds of standards for both hardware and software were decided as JT-60 standards at Japan Atomic Energy Research Institute (JAERI). CAMAC standards were adopted for input/output signals from sensors /to actuators and for data transfer between the computers.

(4) Protective interlock by both software and hard-wired systems

The safety philosophy was established by taking into account certain key requirements in the design of the JT-60 control system. One of the most important requirements is personnel safety. This stems from use of high electric voltage, high magnetic field and possible radiation in the JT-60 tokamak. Hence, the protective interlock system with hard-wired relay logic backs up the computer system from the view point of reliability and safety. Moreover, the concept of precaution and protection was introduced in the system design.

3. SYSTEM CONFIGURATION

3.1 Control Configuration

The control concept of the JT-60 tokamak can be classified into two categories. One is control for plant control and monitoring and the other is for plasma control via actuators used for tokamak discharge.

The concept of plant support control is similar to that in other large-scale facilities such as manufacturing and power

plants. Plant support control is provided for controlling conditions of machines and monitoring their status. Included are on systems for operation-mode control, alarm monitoring, emergency control, protective interlock, etc. These control systems are supported by a complex system of computers and CAMAC systems named the "plant support and monitoring" system.

Sequence control of the actuators and fast feedback control of plasmas are included in the plasma discharge control. This control concept stems from a distinctive feature in the tokamak operation where plasma discharge with duration of a few tens of seconds is executed every few tens of minutes. The plasma discharge control is executed via three complex systems of computers and CAMAC systems named the "discharge control", "real-time control" and "feedback control" systems. Timing systems are also used for supplying trigger pulses and clock pulses in the discharge sequence control and the real-time and feedback plasma control.

The computer configuration of the JT-60 control system is shown in Fig. 1.

3.2 ZENKEI Computer System and Changes of Its Configuration

The computer system for ZENKEI was originally composed of seven 16-bit minicomputers of HIDIC-80Es (Hitachi Ltd.) having main memories of 320 to 448 KW. The cycle time of CPU is 0.48 μ sec. Five of them, having a shared memory of 128 KW, were located in the JT-60 computer room. The rest, having a shared memory of 64 KW, were in a local control room of the rectifier building. The first five CPUs are used for the plant support and monitoring (Ia), the discharge control (Ib), the real-time plasma control (Ib^R) and their man/machine interface (Ia^M and Ib^M). The latter two (Iib) were used for making a feedback control loop for plasma equilibrium control in combination with direct digital controllers (DDCs) in the poloidal field coil power supply. The Iib computer was connected to the Ib computer through an optical linkage bus named "data freeway". Since the ZENKEI

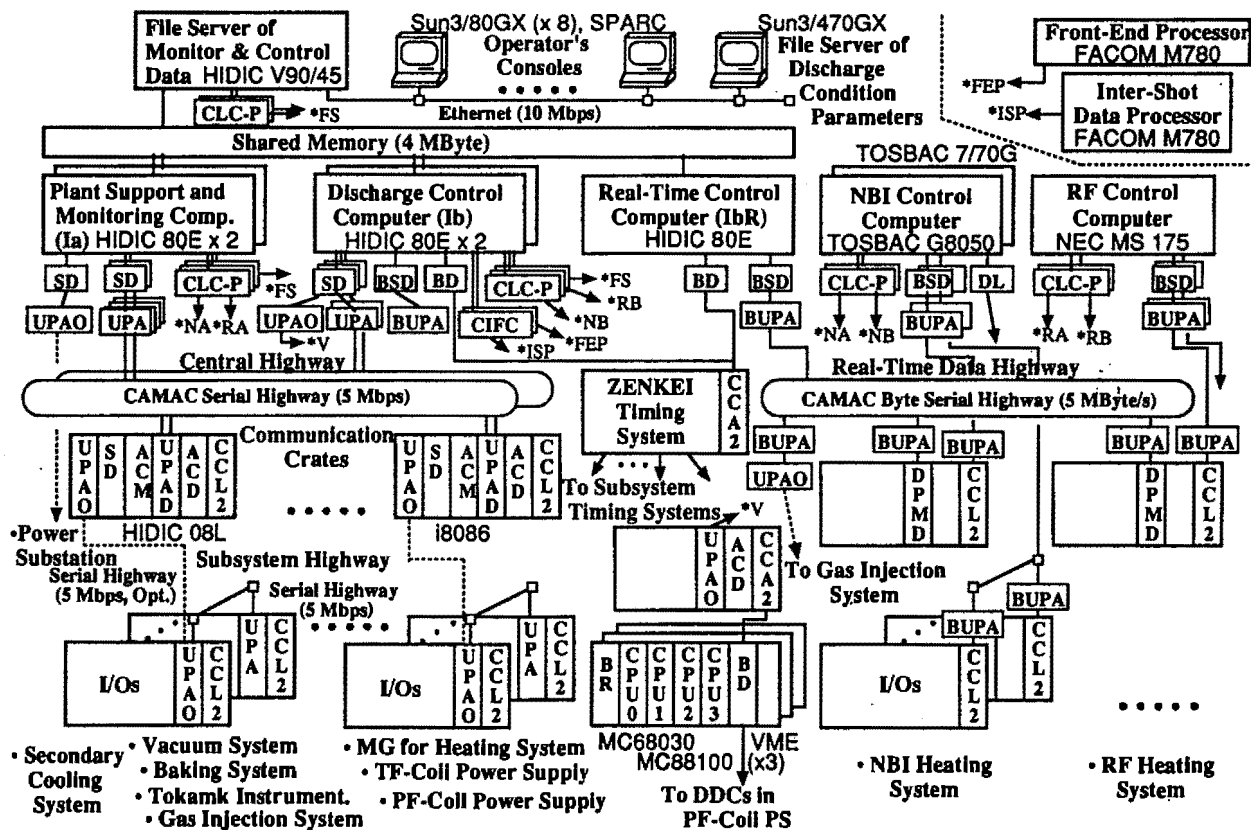

Fig. 1 Computer Configuration of the JT-60 Control System

computer system is a multi-bus system with I/O buses that are controlled through both of PCMA (Processor Controlled Memory Access) and DMA (Direct Memory Access) channels, the CPUs can share their peripherals of disks, printers, etc. A real-time operating system named "Process Monitor System-M (PMS-M)" is employed in this multi-computer system. The PMS-M has the functions of inter-CPU watching, control of tasks under other CPUs, control of I/Os shared by multi-CPU, etc.

The configuration of the ZENKEI computer system has been changed along with the progress of the past five-year operation. The feedback control was originally performed by one of HIDIC-80Es and the other is for back-up. Since the requirements for the control system were increased, the IIB system was, then, modified to be a pipelined system by using the two HIDIC-80Es. Moreover, a preprocessor system with digital signal processors (DSPs) was added to the pipelined system. Coping with the requirements for faster and more accurate control in the JT-60 upgrade, the minicomputers in the IIB system have been superseded by a VME-based multiprocessor system equipped with 32-bit RISC processors. Modern workstations connected via an Ethernet network have been introduced for improving the ZENKEI man/machine interface, which previously was implemented on two of the minicomputers HIDIC-80Es and consoles with dedicated character and graphic terminals.

4. DATA COMMUNICATION AND CAMAC SYSTEM

4.1 JT-60 Monitoring and Control Data

The JT-60 control system handles a large amount of data for plant support and monitoring and for discharge and plasma control. The plant support and monitoring system must send device status data for each subsystem to the central control computer every 5 sec to 1 minute. The number of monitoring points amounts to about 7500 analog and 9500 digital inputs. Second, it must possess sufficient data transfer capability so that operators are able to watch the discharge results and quickly decide the conditions for the next shot. The original discharge data amounted to about 3 MB per shot (10 sec discharge duration) every 10 minute in the standard operation scheme. At present, the data amounts to about 8 MB due to increase of the discharge duration corresponding to the upgraded JT-60 tokamak. Thirdly, it must exchange several tens of control commands and status data with each subsystem every 10 msec for the real-time control and every 1 msec (250 μ sec for the upgrade) for the feedback control of plasma position and shape.

4.2 Communication Systems

As shown in Fig. 1, a hierarchical structure was adopted in the CAMAC highway network corresponding to the hierarchical structure of the JT-60 control system described in

the previous section. The ZENKEI computers of HIDIC-80Es are connected to the subsystems that constitute a major part of the JT-60 facility through the nodal crates called communication crates. Various types of CAMAC highways (central highways) are used depending on their data communication requirements [3]. Some of the central highways are composed of dual serial highways for reliability. As the NBI and RF heating systems and the data processing system for plasma diagnostic instruments have their own minicomputers and a general-purpose large computer, the ZENKEI computers are also connected to them through their dedicated inter-computer linkage buses. The ZENKEI discharge control computer is also connected to a front-end processor at the Japan Atomic Energy Research Institute (JAERI) computer center, where the JT-60 experimental database is created. For local data transfer, each subsystem controller has its own highways named subsystem highways, device highways and local test highways.

The module configuration of the communication crate on the central highways in the Ia and Ib computer systems is shown in Fig. 1. An auxiliary controller with D-port (ACD) is installed in the crate as a mail-box module for communication. A dual-serial U-port adapter is used for conversion of the signals from/to the serial highway to/from the ACD. Besides the ACD module, two intelligent modules are installed in the crate. One is a crate controller which is driven by the local test highway. The other is an auxiliary controller with a 16-bit microcomputer of Intel 8086 or HIDIC-08L (ACM). These were developed by Hitachi Ltd. and Toshiba Co. respectively. The crate controller, the ACD and the ACM can control the dataway in that order of priority.

The ACD is a 3-wide CAMAC module which interfaces to the backplane dataway and the serial highway D-port at the front panel. It has two 16-bit, 2 KW buffer memories and two 24-bit data registers where the replies in the handshake protocol of the communication are written and read.

As the ZENKEI computer system must supervise many subsystems, a more efficient method than CAMAC is required for the data communication between ZENKEI and the subsystem controllers. Hence, the protocol and data format of this transfer extends the CAMAC standard to include a so-called "variable word-length" transfer. A single command can follow a block of data in conjunction with the function of the dedicated serial driver for HIDIC-80E. This variable word-length data transfer can operate about 2.5 times faster than the standard protocol. Furthermore, since each subsystem was contracted to industry separately, the handshake protocol and data format for the communication between the ZENKEI computers and the subsystem CAMACs were standardized as JT-60 standards at JAERI.

These communication systems allow full data transfer in spite of the increase in the amount of data, in particular the increased amount of discharge and feedback control data in the JT-60 Upgrade.

5. DISCHARGE SEQUENCE CONTROL AND TIMING SYSTEM

5.1 Discharge Sequence

Discharge control involves establishing a set of condition parameters, implementing the discharge and collecting data resulting from the discharge. This process is repeatedly performed due to the pulse operation of the JT-60 tokamak. Various types of discharge sequence have been prepared for high power pulse discharge, discharge cleaning and test operation. The concept of the sequential control phase was introduced for synchronizing the status of ZENKEI and the controllers of the subsystems used as the discharge actuators. The standard shot interval was originally designed to be 10 minutes. The discharge sequence is implemented by command and reply messages between the Ib computer and the subsystem controllers in conjunction with trigger pulses for the actuators generated by the timing systems.

The functions of so-called "pre-shot check" and "post-shot check" on the machine status are prepared for the precaution of machine troubles. The Ib computer in association with the alarm systems installed in the Ia computer and the hard-wired interlock system performs the discharge termination for protection of the machines at the occurrence of abnormal events according to their levels of seriousness.

5.2 Timing System

In the design of the timing system, consideration was given to safety, precision and reproducibility, correction of disorder in control sequence and linkage with real-time plasma control. In order to satisfy these requirements, we made provision for the timing system to have (1) control interlock, (2) timing pulse transfer with response recognition, (3) event-oriented control and (4) command output by computer access.

The timing system is characterized by the following four kinds of CAMAC modules: a clock pulse generator (CPG), a timing pulse generator (TMG), a timing pulse transmitter (TGT) and a timing pulse receiver (TGR). The timing system is under the control of the Ib and Ib^R computers through CAMAC highways.

The CPG generates the 1-msec clock pulse which is used as an external count-down clock to the TMG. The clock pulse is also used as an interruption signal of the control cycle in the real-time plasma control. The TMG has five 16-bit presetable counters. Hence, the sequence control from 60 sec before the discharge to the termination of discharge is performed with an accuracy of 1 msec. Each counter can generate a timing pulse when the "AND" condition is satisfied with its time-up and the event signal given by the computer in the discharge sequence. Transmission of the timing signal is executed by a handshake procedure by using an "acknowledge (ACK)" signal in combination with the TGT and TGR modules. The TGT module can encode and transmit 16-channel timing signals and the TGR module receives and

decodes them and replies the corresponding "ACK" signals to the TGT within 40 μ sec. In case of faults occurred in the trigger pulse generation by TMG and the transmission by TGT and TGR, Look-At Me (LAM) signals are available for the Ib computer to terminate the discharge sequence.

6. PLASMA CONTROL

A control system has to be designed according to its control objective, which implies sufficient understanding of the system including the objective. Since this premise did not always hold for the tokamak plasma, the control system was required to have a wide range of flexibility to tune the control method. Reliability was also required from the view-point of availability of the control system. To satisfy these requirements, we decided to build a fully-digital control system with digital computers and CAMAC-standard equipments [4]. Thus, we were able to prepare many variations of plasma control structure, by changing the discharge condition setting. In spite of the system having this flexibility, we often changed the control system by replacing computers with more advanced ones.

In this section, the present system structure and performance for the JT-60U plasma control are described.

6.1 Outline of System Configuration

As shown in Fig. 2, the JT-60 plasma control system contains two feedback loops. The major loop controls plasma heating and gas fueling and the minor loop controls plasma position and current via five sets of poloidal field coils. The control cycle of each loop was determined by its control objectives. The cycle time of the major loop is 10 msec and the minor one is 0.25 and 0.5 msec.

In the major loop, the Ib^R computer supervises the controllers of the gas injectors and the NBI and RF heating systems by using a byte-serial highway for the transfer of status data and control commands during a shot. A dual-port memory module with D-port (DPMD), which has two 16-bit, 128-word buffer memories, is installed in each communication crate in the Ib^R highway as a mail-box module for the fast data transfer. In order to increase the data transfer speed, the byte-serial driver, which was developed for HIDIC-80E, has a "command buffer" to burst CAMAC functions and data to the highway.

A VME-bus system has the characteristics that (1) we can utilize advanced micro-processors with 32-bit or more accuracy, (2) its system clock (16 MHz) is faster than the CAMAC system clock (5 MHz), (3) VME-bus modules interfacing with CAMAC systems are on the market, etc. In the minor control loop, faster and more accurate computation were required for plasma position and current control at the JT-60 upgrade. Hence, we decided to supersede the old 16-bit minicomputer-based feedback control system (IIb) and the 16-bit microcomputer-based DDCs by VME-based systems equipped with advanced 32-bit microcomputers [5].

Table 1 Computer Specification

RISC Microprocessor [MVME181]	
MC88100 RISC Microprocessor at 20 or 25 MHz 16 to 20 VAX MIPS	
HIDIC-80E	
Cycle Time: 0.48 μ sec, 0.8 MIPS, 0.3 FLOPS	

Table 2 Data Transfer Rate

HIDIC-80E (BSD)	K words to 1 crate/module
~ DPMD	Time = $80 + 2.8 \times K$ (μ sec)
MVME181 (CBD)	K words to any crate/module
~ ACB	Time = $2.4 \times K$ (μ sec)

The new IIB control system is composed of 4 VME racks, which are connected with each other through 6 bus repeater/expanders (PT-VME902A-1, Performance Technologies, Inc., U.S.A.). Three MC88100 based RISCs named MVME181 (Motorola Inc., U.S.A.) are installed in one of the racks. The other three racks are equipped with I/O modules. The parallel and pipe-lined processing of signal inputting, calculation of plasma state variables, feedback calculation and command output by using the three RISCs is synchronized by interruption from a 250- μ sec clock pulse given by the timing system and the flags transferred between the RISCs through VME-bus. The programs in the RISCs are written in C language. The host computer for developing the VME microcomputer programs is a Sun3/140M workstation (Sun Microsystems, Inc., U.S.A.).

The old 16-bit microcomputers (i-8086 based ACMs) in the DDCs were superseded by VME-based 32-bit microcomputers named MVME147 (Motorola Inc., U.S.A.). I/O modules, however, are installed in the DDC CAMAC crates as before.

Another CAMAC crate is provided for transferring data between the IIB and the DDCs and between the IIB and the IIB computers. The VME racks in the IIB system are connected to the CAMAC crate via a CAMAC branch driver (CBD8210 made by Creative Electronic Systems, Switzerland), a branch highway and a type-A2 crate controller (CCA2 made by Standard Engineering Corp., U.S.A.).

Specifications on the computational speed of the computers used in the plasma control system are summarized in Table 1. Data transfer rates are also shown in Table 2.

6.2 Performance of Plasma Control

The newly developed plasma control system is working well in the initial experiments at the JT-60 upgrade. Stable deuterium plasmas with plasma current up to 5-MA and the NBI power of 20 MW have been produced. The plasma position and current are well controlled by PD (proportional and differential) control with matrix gain. For example, the differences of the state variables between the observed and desired values in a 4-MA divertor plasma are about 15 kA for the plasma current and less than about 1 cm for the plasma horizontal and vertical positions and the height of X-point (a cross point of the separatrix line of plasma boundary). Dynamic switching of the control scheme is available for sophisticated control in the initiation and termination of plasmas. The phase control also functions well for discharge termination in association with the computer and hard-wired discharge fault systems.

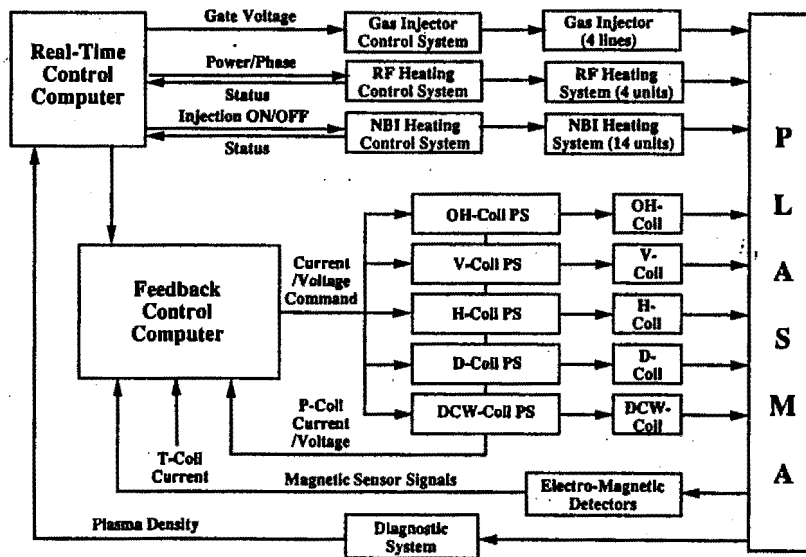

Fig. 2 Data flow of the JT-60U plasma control system

Content from this work may be used under the terms of the CC BY 4.0 licence (© 1992/2024). Any distribution of this work must maintain attribution to the author(s), title of the work, publisher, and DOI

7. MAN/MACHINE INTERFACE

As the man/machine interface for the JT-60 plasma operation, the ZENKEI control system uses modern workstations for operator's consoles. A large mimic panel is provided for displaying overall status of the JT-60U. ZENKEI also has an ITV system and a broadcasting system. Each subsystem has its own console for the individual operation. The subsystem console is equipped with some CRTs having keyboards or light pens, button switches, mimic panels and alarm annunciators. These consoles are located in the JT-60 central control room. For individual operation of the subsystem devices, each subsystem also has its local console.

In the experience of the past five-year plasma operation, one of the most troublesome operations was the operation of setting the discharge condition parameters. As described in Section 5, this operation must be implemented within a short time during a shot-interval. Problems arose because of inefficient consistency checks among the condition parameters and lack of guidance for the setting. Improvement of the functions of plant monitoring and discharge results data display was also required for the efficient and comfortable operation in the JT-60 experiments. For example, the ZENKEI operator's consoles before the upgrade were equipped with old type color semi-graphic and B&W graphic terminals. We were not able to use Japanese characters in these terminals. Moreover, it was required that the layout of the consoles was changed in order to increase the number of consoles for the plasma diagnostic devices.

In order to cope with the above requirements, no more room to install new programs for the improvement was left in the original computer system because it was designed 10 years ago. Memory sizes were small. The peripherals were so old that we could not make "user-friendly" interfaces. Hence, the hardware which composed the operator's consoles has been superseded by the modern workstations connected through a network [6].

As shown in Fig. 1, the new man/machine interface at the central level consists of ten workstations: Sun3/80GX and AS4040 (SPARC) (Toshiba Co., Japan) as the operator's consoles, one workstation of Sun3/470GX (Sun Microsystems, Inc., U.S.A.) as a file server of the discharge condition and a 32-bit industry control computer of HIDIC-V90/45 (Hitachi, Ltd.) as a file server of plant monitoring and plasma control data (We shall call it SVP). The workstations are installed on ordinary OA desks. Hence, the layout of the consoles in the control room can be easily changed. The SVP computer, which works under a combination of real-time and UNIX operating systems, is connected to the workstations through an Ethernet network. The SVP computer can share the 4-MB memory with the existing minicomputers of HIDIC-80Es. The shared memory is used for transferring a large amount of discharge result data. A DMA-controlled 16-bit parallel bus, whose controller is named CLC-P, is also provided for transferring a small amount of data such as event data from alarms and the discharge sequence from the HIDIC-

80Es to the SVP. The TCP/IP protocol is used for data communication on the network. The NFS (Network File System) protocol is also used as an application-level protocol for a large amount of data transfer. The application software in the new man/machine interface of these functions are written in C language. A window manager "SunView" is fully used in the displays of these control functions on the workstations. Multiple windows are displayed and Japanese characters are available. Click operation with a mouse can be used in the operation such as selection of items on the displays via "pop-up menus" and "panel windows" of "SunView".

The new ZENKEI man/machine interface has been fully used in the initial operation of the JT-60U. The load on the operators has been reduced. In particular, mistakes in the operation of setting the discharge conditions has been greatly reduced and the operational efficiency has been increased. This resulted in the decrease in the number of the operators. Some lessons remain from the view point of time response. For example, when the operator wants to display waveforms of discharge result data with a large amount of data points, he can not wait for the display without irritation.

ACKNOWLEDGEMENTS

The author wish to thank the members of Control Group in Division of JT-60 Facility I at JAERI for their collaboration in the development of the JT-60 control system.

REFERENCES

- [1] H. Ninomiya, et al., "JT-60 Upgrade Device for Confinement and Steady State Studies," *Plasma Devices and Operations*, vol. 1, 1990, pp.43-65.
- [2] I. Kondo, et al., "The JT-60 Central Control System," *Fusion Engineering and Design*, vol.5, 1987, pp.69-84.
- [3] T. Kimura, et al., "Communication System in JT-60 Control," in *Proceedings of the 10th Symposium on Fusion Engineering*, Philadelphia, 1983, pp.398-404.
- [4] K. Kurihara, et al., "JT-60 Plasma Control System," *Fusion Engineering and Design*, vol.11, 1990, pp.441-454.
- [5] T. Kimura, et al., "VME Multiprocessor System for Plasma Control at the JT-60 Upgrade," *IEEE Trans. on Nuclear Science*, vol.35, 1989, pp.1554-1558.
- [6] I. Yonekawa, et al., "A New Workstation Based Man/Machine Interface System for the JT-60 Upgrade," to be presented at this conference.