

# NSLS II CONTROL SYSTEM

Leo Bob Dalesio (BNL, Upton, NY)

## Abstract

The NSLS II is a new light source to be built at Brookhaven National Laboratory. The control system tools will be started this year. Technical areas of interest to improve productivity, maintainability, and performance, include Relational Database tools to support all aspects of the project, online Bbam modelling, intelligent distributed device controllers, and engineering and operation tools. We will discuss our goals and projects to make progress in these areas.

## INTRODUCTION

The National Synchrotron Light Source II [1] (NSLS II) is a new 3<sup>rd</sup> generation light source being built at the Brookhaven National Laboratory in Upton, New York. This new facility is planned to be operational in the 2013 time frame. In this paper, we discuss the requirements, standard solutions to be used, areas for development, risk analysis, and budget.

## REQUIREMENTS

The injection bunch length is 11-15 psecs. It has a 2.6 usec ring revolution time. The beam in the storage ring is to be topped off every 1 minute. The top off bunch train is 200 nsec. Top off damping time is 10-30 msec, during which there can be no beam extraction.

The control system must provide manual control of orbit trims, quadrupoles, sextupoles, and insertion. Approximately 10 Hz write/read is suitable for “turning knobs” for a power supply. The updates to the operator must provide 5 Hz updates to operators for up to 1000 chosen parameters. Archive capability for up to 6000 parameters at a rate of .5 Hz continually must be provided. The control system must scale to support 150,000 physical I/O connections and 400,000 computed variables. The aim for availability of the control system is 99.99%, 24 hours per day, 7 days per week.

The control system integrates all subsystems: diagnostics, low level RF, power supply control, vacuum control, facility control, insertion device control, beam line control, equipment protection and personnel safety.. It supports a loop time of 1 Hz for model based control. 10 kHz power supply read backs triggered from timing system to detect ripple, support fast orbit feedback, and correlate power supply behavior with beam behavior. It must support 10’s of Hz Data Collection for RF loop correction. Fast feedback system at 5 KHz are provided for RF Feedback on beam phase and orbit feedback using 180 BPMs and 120 Corrector PS in 30 I/O Controllers (IOC). The timing system must provide triggers with

under 80 psecs pulse to pulse timing jitter. There are 20 msec from detection of a beam envelope violation to equipment protection mitigation To support the diagnosis of orbit, coherent turn by turn orbit data for up to 800 channels for any arbitrary 1024 turns must be available. In fault situation, all storage ring parameters must be latch for the last 10 seconds of data from all parameters.

## CONTROL SYSTEM STANDARDS

The NSLS II is EPICS based. It will use standard EPICS[2] engineering tools: Extensible Display Manager [3], Channel Archiver[4], Striptool, and the Alarm Handler for operator support. Visual Database Configuration Tool w/ modifications for “Table Entry” will be used for EPICS database configuration. Standard tools will be selected for the operator log, error log, and other generic functions. For high level applications, the Matlab Middle Layer Toolkit (MMLT)[5] and eXtensible Accelerator Language (XAL) [6] will be used. The MMLT is in use at LBL, Spear, Diamond, SLS, CLS, and ASP. XAL runs at SNS and J Parc.. Embedded Real-Time Operating System choices are: RTEMS[7] which is in use at LCLS, Spear, and CLS or VxWorks which is in use at APS, SNS, Diamond, and SLS. Linux Workstations will be used in the control room.

## COMPONENTS FOR SLOW CONTROL

The control system uses a standard architecture for slow control components. Those subsystem that require no synchronization may be put into a remote scanning system such as a PLC or subsystem with some serial or Ethernet communication to pull the data into the EPICS environment for time stamping and distribution to all other tools. Those devices that require the VME instrumentation bus or require up to 60 Hz synchronization will be done in the VME or cPCI architecture.

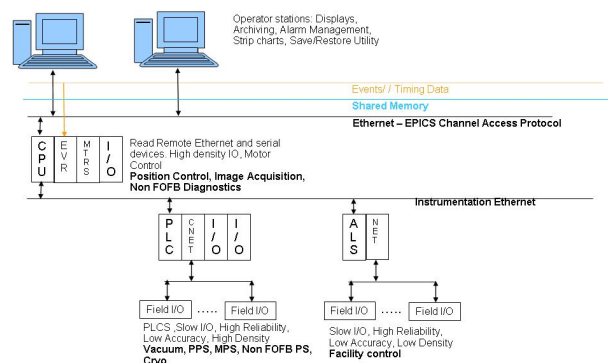

Figure 1: Hardware architecture for Slow Subsystems.

\*Work performed under auspices of the U.S. Department of Energy under Contract No. DE-AC02-98CH10886 with Brookhaven Science Associates, LLC.

## CONTROL COMPONENTS FOR HIGH SPEED, LOW LATENCY APPLICATIONS

The control system must use special components for low latency, deterministic components that support sub-millisecond applications for fast orbit feedback, machine control, and RF phase control. Some of these components are available from a single commercial sources like the Libera BPM [8] from ITech and the EVG/EVR timing [9] hardware from Micro Research.. It may be possible to extend the commercial boards to provide the capabilities needed. The primary issue is that these components strictly limit the sources for these boards and all carry currency risks. Alternatively, the development of an open-source framework for providing the timing, synchronization, and data communication required is under consideration. The conceptual design for this hardware employs low cost, readily available commercial components to provide this functionality. This design is done by Larry Doolittle from LBL lab. A group of experts in this area will be used to review and evolve this design. The goal is to provide a platform for any commercial or laboratory group to use to provide device controllers for this high performance environment. A prototype of this functionality is planned for late 2008.

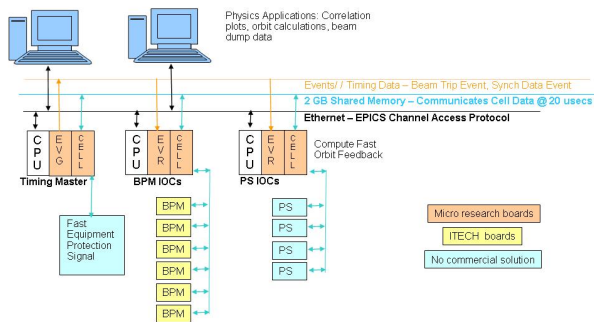

Figure 2: Hardware Architecture for high speed, low latency applications.

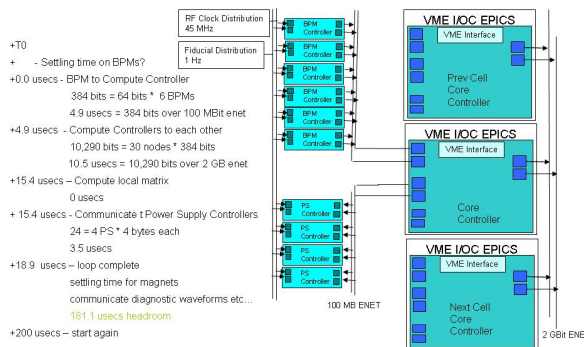

Figure 3: Embedded Device Controller Architecture.

## HIGH LEVEL APPLICATIONS

To support the development of high level applications, an online model will be installed very early in the project. The simulation is based on Tracey-2 [10] and runs under the I/O Controller (IOC). In the early stages, the Matlab Middle Layer Toolkit will be installed and operate against the online simulation. A development effort is planned to develop a client/server architecture for high level applications. This development will take an incremental approach to developing this architecture. The first application to provide as a server is a name mapper to provide name aliasing and introspection for families of magnets and composite values such as orbit. The second application currently planned is a server for the Lattice information. The picture aside shows the scope of the work envisioned for this project. The client/server middle layer is developed to provide access to all other traditional data as services. These services are to be ported into this environment incrementally. Close discussion and collaboration with as many high level applications packages as possible is desired. At present, we are working closely with the MMLT and XAL groups.

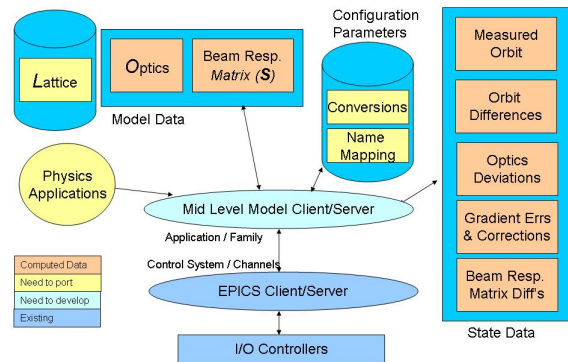

Figure 4: High Level Application Software Architecture.

## RISK ANALYSIS

There are three identified risks for the control system for NSLS II. The primary risk is the assembly of the control group. The budget calls for around 15 full time engineers/programmers/physicists. These break down further to 2 RDB experts, 4 high level application programmers, an EPICS expert, and 8 project engineers. The risk here is heightened by the fact that both RHIC and NSLS I remain operational through the construction and commissioning of the NSLS II. This risk is being mitigated by an early, aggressive recruiting effort, the building of collaborations for specific areas, and the use of commercial companies to augment our manpower to provide specific packages and perhaps project engineering support.

The second concern is the availability of a platform to implement low latency, high speed, time synchronous,

applications such as fast orbit feedback and machine protection. We have started to work with the engineers at Diamond, SLS, and LBL along with current board manufacturers to develop this platform. As a fallback, the commercial components from Diamond could be used.

Our last risk is in the use of our RDB to maintain all of our application parameters. We are starting early and leveraging off of others in the community, particularly with the IRMIS [11] tools developed at the APS. Use of the IRMIS database gives us a large head start on component, wiring and hardware support. Our early developments will focus on capturing the name mapping and Lattice information. Others have survived without this handled properly, but the result is a less efficient and dangerously unmanaged source of critical design parameters.

### SCOPE AND BUDGET

The NSLS II control system includes the integration of all subsystems in the accelerator, beam-lines and facilities. It provides all global systems and utilities. We plan to leverage on all of the excellent work that has been done previously with particular attention to those most recently completed at Diamond, Spallation Neutron Source, and the Swiss Light Source. The table below outlines the overall funding and manpower.

Table 1: Manpower and Cost Estimates

WBS Description	Direct \$		
	FTEs/yr	Total FTE Costs	Total Material
1.03.05.01 – 1.03.05.09 Apps: Diagnostics, RF, Power Supply, Vacuum Subsystem Integration of: Insertion Devices, Beam lines, Safety Systems, Facility	7	5.3 M	1.9 M
1.03.05.12 Timing	1.5	1.2 M	0.4 M
1.03.05.11 & 1.03.05.13 High Level Applications	6	4.8 M	0
1.03.05.10 Accelerator Control Room		75K	0.2 M
1.03.05.11 Network	.5	0.3 M	1.3 M

### CONCLUSION

The NSLS II has significant challenges, particularly in the assembly of a talented team to take on significant challenges and development. There is budget and plans to move control system technology forward in the areas of embedded control, high level application infrastructure and the application of relational databases. With the right staff, good collaborators, and a great start from those that went before us, the NSLS II should achieve all stated goals with the resources and schedule available.

### REFERENCES

- [1] “Philosophy For NSLS-II Design With Sub-Nanometer Horizontal Emittance”, S. Ozaki#, J. Bengtsson, S. L. Kramer, S. Krinsky, V. N. Litvinenko BNL; MOOAB01, Proceedings of PAC 2007, Albuquerque, NM.
- [2] “EPICS Future Plans”, Clausen, M., et. Al., ICALEPCS 2007, FOPA02.
- [3] Extensible Display Manager (EDM) by John Sinclair, ORNL. Web page: <http://ics-web1.sns.ornl.gov/edm/>.
- [4] Channel Archiver by Kay Kasemir, ORNL, web page: <http://www.aps.anl.gov/aod/bcda/epicsgettingstarted/starttools/channelarchiver.htm>.
- [5] “Automated Beam Based Alignment of the ALS Quadropoles”, G. Portmann, D. Robin, and L. Schachinger, Lawrence Berkeley Laboratory, Berkeley CA 94720 USA, May 1-5, Proceedings of PAC 2005, Dallas, Texas.
- [6] “XAL Status”, Pelaia, T., et. ICALEPCS 2007, Al., MOPB02.
- [7] RTEMS, open source real-time OS <http://www.rtems.com/>.
- [8] Libera BPM by Instrumentation Technologies, Slovenia, <http://www.i-tech.si/products.php>.
- [9] Event System by Micro-Research Finland, <http://www.mrf.fi>.
- [10] J. Bengtsson, “TRACY-2 User’s Manual”, SLS Internal Document, February 1997; M. Bøge, “Update on TRACY-2 Documentation”, SLS Internal Note, SLS-TME-TA-1999-0002, June 1999.
- [11] Don Dohan, “The IRMIS Universal Component-Type Model”, this conference, TOPA03.