

## THE TILECAL DETECTOR CONTROL SYSTEM\*

Joao Pina, Agostinho Gomes, Carlos Nuno Marques (LIP, Lisboa), Tiago Rodrigues Vieira Batista, Luis Granado Cardoso, Bernardo Sotto-Maior Peralva (CERN, Geneva), Giorgi Arabidze, Nikos Giokaris (University of Athens, Athens), Mohamed Ouchrif (Université Blaise Pascal, Clermont-Ferrand), Laura Sargsyan (YerPhI, Yerevan)

### Abstract

TILECAL is the hadronic calorimeter of the ATLAS detector that is being built at CERN. The main task of the TILECAL Detector Control System (DCS) is to enable the coherent and safe operation of the detector. All actions initiated by the operator and all errors, warnings, and alarms concerning the hardware of the detector are handled by DCS. TILECAL DCS design is finalized and almost implemented. All the main systems are implemented and working and certified for operation when ATLAS start taking data in 2008.

### INTRODUCTION

TILECAL, the hadronic calorimeter of the ATLAS detector, is a sampling calorimeter made of scintillating tiles readout by wavelength shifting fibres, using iron as absorber and photomultipliers (PMT's) as photodetectors [1]. The PMT's and part of the front end electronics [2] are located on the outer side of the modules. TILECAL is composed of 3 cylinders, one central barrel and two extended barrels. Each cylinder is composed of 64 modules.

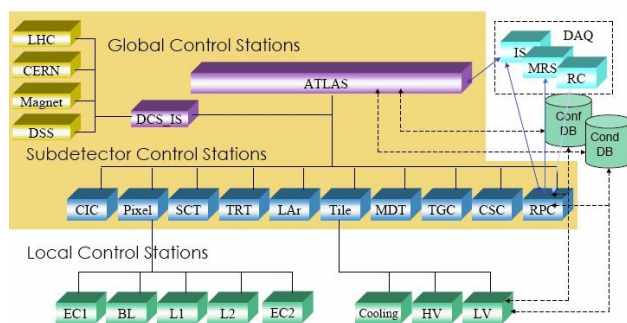

Figure 1: Hierarchical organization of the ATLAS DCS Back-End system.

The DCS architecture [3] consists of a distributed Back-End (BE) system running on PC's and different Front-End (FE) systems. In order to provide the required functionality, the BE system of the ATLAS DCS is organized hierarchically in three layers or levels as shown in figure 1. This hierarchy allows the experiment to be divided in independent partitions which have the ability to operate in standalone or integrated mode.

The TILECAL main DCS systems control and monitor the Low Voltage (LV) power system, the High Voltage (HV) system and the cooling of the electronics. Other control systems exist for the calibration related systems:

cesium calibration source and laser monitoring. The calibration related systems will have their own control systems, independent of DCS, but will exchange data and commands with the TILECAL DCS. In 2005 the commissioning of TILECAL started, including all components of DCS. This phase continues until the start of detector operations foreseen in 2008.

### SYSTEM TOPOLOGY

The logical structure of the TILECAL DCS is subdivided in blocks, attending to functional criteria, and structured in a tree-like way in order to give to the user a better view of the control system. All functional blocks can run autonomously. The system comprises the following blocks:

**High Voltage system:** required for the operation of the PMT's

**Low Voltage system:** required for a proper operation of all the readout electronics and for the HV regulation

**Cooling system:** monitoring and control of the TILECAL cooling sectors which keep all the electronics inside the correct temperature range

The TILECAL DCS will be divided in four sectors all identical from the logical point of view, two for the central barrel regions and two for the extended region. Each sector is composed of one Cooling, HV and LV partition. The hierarchy of PC's in TILECAL includes only 2 layers, a top layer with the TILECAL Control Station, and a bottom layer with 4 Local Control Stations (LCS), one per sector.

### SOFTWARE

PVSS II a Supervisory Control and Data Acquisition (SCADA) software from the Austrian Company ETM is used for the supervision of the ATLAS detector. Several functionalities are used like human-machine interface, alarm handling, archiving, trending, access control, etc, and also sets of interfaces to hardware and software.

For field bus communication TILECAL DCS makes use of the Controller Area Network (CAN) based protocol CANopen. For this a dedicated Open Protocol Communication (OPC), CANopen server was developed by the ATLAS central DCS team. This server fulfils all the CANopen functionality required by the cards called Embedded Local Monitor Board (ELMB) [4], the core of the LV power supplies control and monitoring system. The HV system also uses Distributed Information Manager (DIM) [5]. In order to communicate between the Micro boards and the PC, the HV system also uses Distributed Information Manager (DIM) [8], a

communication system for distributed environments developed at CERN that provides a network transparent inter-process communication layer. For storing the data, TILECAL DCS uses the ORACLE databases provided by ATLAS.

## TILECAL DCS MAIN SYSTEMS

A brief description of the most important TILECAL DCS systems is presented, giving emphasis on the performance of each system.

### *The High Voltage System*

The TILECAL High Voltage system [6] is based on HV bulk power supplies located in crates that provide a common high voltage for each set of photomultipliers. For a common set of photomultipliers there is a regulator system (HVopto board) that provides fine adjustment of the voltage for each individual photomultiplier over a range of 350 V below the input voltage. Each set of two HVopto cards is controlled by another board called, HVmicro card. In total each HVmicro board controls 68 channels of 5 different types with a reading rate of 0.1Hz. The communication with the HVmicro is done via CANbus connected in daisy-chain. This daisy-chain is connected to the PC through Kvaser PCican card with 4 ports, which distributes the connection with the modules in 4 branches of 16 drawers each. The communication between the PC and the bulk power supplies is done by RS422 through a TCP/IP gateway.

The HV DCS system implemented in 2007 uses the driver that communicates with the HVmicro boards interfaced with a DIM server. PVSS DIM client is used to transfer the data and the commands to the SCADA system.

The HV system is the most important system of the TILECAL DCS. The DCS besides ensuring the good behaviour of the HV system during operation is also responsible to read and store the applied voltages on the photomultipliers. In total, HV DCS will monitor more than 20000 parameters. Further, it needs to supply those values to the off-line data reconstruction group. Photomultipliers gains can change with time and new calibration needs to be applied so it is necessary to store in database all the values set during the lifetime of the experiment.

A stability study performed in 2004 on 288 photomultipliers, 3% of the total of the whole detector, during 31 days, showed that maximal fluctuations of the HV of a PMT during operation were of the order of 1 V. A new stability test is under way and results are foreseen before the end of 2007.

### *The Low Voltage System*

The low voltage system is composed by three devices: a low voltage power supplies (LVPS) located inside the

“finger” region of modules of the calorimeter, auxiliary boards which power and control 4 LVPS and bulk power supplies providing 200V DC. The LVPS provide the voltage and current needed for the operation of the electronic boards inside the calorimeter. Each LVPS uses 200 V DC as input to supply eight voltages from 3.3V to  $\pm 15V$  with a maximum fluctuation of  $<1\%$ . The control of the output levels is made by 4 channels 12 bit DAC's Maxim525. Power for the ELMB and respective motherboard comes from the Auxiliary boards. The Auxiliary boards are installed in crates far from the detector and they also allow switching on and off the output levels, and provide a clock for module synchronization.

The monitoring of both the LVPS and auxiliary board is provided by the ELMB's which also make the control of the Auxiliary boards. The DCS is responsible for the monitoring and control of all the system which has a total of more than 25000 monitored parameters.

### *Cooling System*

The TILECAL cooling system operates with water at sub-atmospheric pressure using a so-called Leakless Cooling System. The system is controlled and monitored locally by a Programmable Logical Controller (PLC). The TILECAL cooling plant cools, purifies and provides primary pressure to the water. The cooling plant supplies 24 individual sectors called cooling loops, 6 per TILECAL sector and each of those cooling loops has one regulator valve allowing them to be independent of each other. The TILECAL DCS monitors the temperature and pressure, of the cooling loops.

### *Finite State Machine*

The DCS Back-End in ATLAS is organized in three functional layers and the Finite State Machine (FSM) is the main tool for the implementation of the full control hierarchy.

The Controls hierarchy and the Partitioning rules are implemented based on PVSS and State Management Interface (SMI). The object model in SMI is described using a dedicated language State Manager Language (SML).

PVSS tools are used to configure the system, to log and archive information and to provide User Interfaces. SMI++ tools are used to model Devices and Subsystem behaviour, to automate operations and to recover from error conditions.

The basic FSM elements are Device Unit (DU) and Control Unit (CU). The DU's provide the interface with the hardware while the CU's (with complex control programs) integrate the DU's on hierarchy. The TILECAL FSM, figure 2, will incorporate over 21 control units and 600 device units.

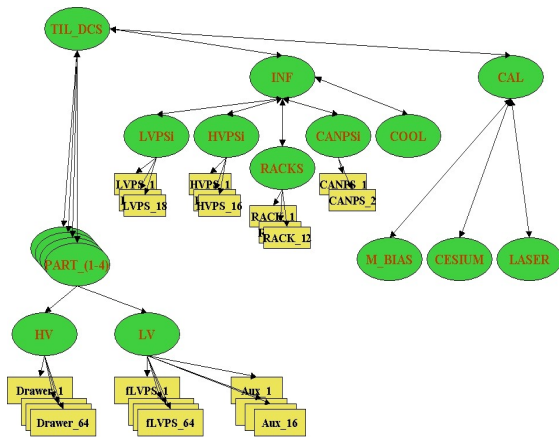

Figure 2: TILECAL FSM Architecture.

### Alarm Handling

At the ATLAS Global control Station level, there is also available an alert status. The alerts work independently of the FSM, however the status may be closely related. Automatic actions can also be triggered by alarms.

### Data Storing

The TILECAL DCS will use three types of database:

**PVSS ORACLE archive:** ORACLE database that stores relevant data for understand detector behaviour.

**COOL Conditions Database:** database which will store relevant data for offline data reconstruction in ATHENA [7].

**Configuration Database:** ORACLE database that will store system structure (lists and hierarchies of devices), device properties (like configuration of archiving, smoothing, etc.) and settings (like output values, alert limits).

The data produced by PVSS is stored in the DCS ORACLE archive, using a Remote Database Manager (RDB). Some of the data stored by DCS is useful for data off line reconstruction, like photomultipliers applied voltage. To make this data available to the ATLAS data analysis software, ATHENA, the COOL database was created, which implements an interval of validity database, i.e. objects stored or referenced in COOL have an associated start and end time between which they are valid. COOL data is stored in folders, which are themselves arranged in a hierarchical structure.

The PVSS-COOL process takes selected data from the PVSS Oracle Archive and copies it into COOL. During this process the PVSS data points types, that represent devices, are associated with a folder, on which data from different devices of the same type are allowed.

The original rate of data produced by the TILECAL DCS during normal detector operation is too high, so smoothing is applied to the data to be stored in the database. Currently, the amount of data that is stored is of the order of 300 MB per day.

## STATUS AND CONCLUSION

The calorimeter is installed in the cavern, and all of the DAQ and DCS electronics is installed. The control system for all the four TILECAL partitions is already installed and partially certified.

The chosen PC's have Motherboard Intel ITSSE7520JR2-ATAD2, Xeon 3.0 GHz dual processor, 2 GB memory, and 3 PCI slots. The hierarchy of PC's includes only 2 layers, a top layer with the TILECAL Control Station (SCS), and a bottom layer with 4 Local Control Stations (LCS), one per partition. In this approach, each LCS has to run all TILECAL DCS main systems and the respective FSM's. The switch on of the complete system takes several minutes, and currently is the only weak point in terms of performance. The most critical component is the low voltage system since, after several hardware problems were found during installation, the control program suffered several changes, namely in the start up procedure (switch on).

Now DCS provides monitoring and control for all of the electronics and the first version of the FSM was successfully tested and continuously improved along new hardware was installed.

During 2007 several Milestone weeks, where the TILECAL DCS, the other sub detectors control systems and the ATLAS central DCS were set up together, allowed to test the integration of the complete ATLAS DCS during runs of data taking.

## REFERENCES

- [1] ATLAS Collaboration, 'ATLAS Tile Calorimeter Technical Design Report', CERN/LHCC/96-42, 1996.
- [2] R. Teuscher, 'Front-End Electronics of the ATLAS Tile Calorimeter', XI International Conference on Calorimetry in Particle Physics, Perugia, 2004.
- [3] H. Boterenbrood, et al, 'Design and Implementation of the ATLAS Detector Control System', ATLAS-DAQ-2003-043; Geneva, CERN, 28 May 2003.
- [4] B. Hallgren, 'The Embedded Local Monitor Board (ELMB) in the LHC Front-End I/O Control System', 7th Workshop on Electronics for LHC Experiments, Stockholm, 2001.
- [5] C. Gaspar, 'Distributed Information Management System', ECP division CERN.
- [6] R. Chadelas, 'High voltage distributor system for the Tile hadron calorimeter of the ATLAS detector', ATLAS Internal Note ATLAS-TILECAL-2000-003, 2003
- [7] ATLAS Collaboration, 'ATHENA The ATLAS Common Framework' CERN, 2001.