

PRELIMINARY DESIGN CONCEPTS FOR THE CONTROL AND DATA ACQUISITION SYSTEMS OF THE ITER NEUTRAL BEAM INJECTOR AND ASSOCIATED TEST FACILITY

A. Luchetta and G. Manduchi, Consorzio RFX – Associazione Euratom-ENEA, Padova, Italy

Abstract

ITER is a joint international research and development project aiming to demonstrate the scientific and technical feasibility of fusion power. The ITER Neutral Beam Injector (NBI, negative H or D ion source, 1MV acceleration voltage, 40A ion current, 16.5MW beam power, 1 hour continuous operation) is a major and innovative component of ITER and will be supported by a dedicated Test Facility (NBTF). The NBI and the NBTF are being designed with the goal to have one injector fully operational on the ITER device in 2016. The two items need separate, but closely interacting, control and data acquisition systems. The NBI control and data acquisition system will manage the NBI device and will be installed at the ITER site; the NBTF control and data acquisition system will manage the test facility and enable extensive scientific exploitation of the NBI before its final installation at the ITER site. The paper reports on the design activity for both control systems, including the definition of the system requirements, the functional system structure and the preliminary system architecture.

INTRODUCTION

ITER is a joint international research and development project that aims to demonstrate the scientific and technical feasibility of fusion power [1]. It will be constructed in France. ITER is a toroidal device based on the physics of tokamak in which the ionized gas (plasma) is heated up to ignition by additional heating and current drive systems injecting either radio frequency or neutral beams. The ITER neutral beam injector (NBI) [2] will produce a beam in H or D. In order not to be deflected by the magnetic field, the beam will contain only neutral atoms. ITER will be equipped with two NBIs, with an option to add a third one. Devices having the technical characteristics required for the ITER NBI have never been built; their construction is a scientific and technological challenge. Table 1 compares the ITER NBI parameters with the parameters of the JET neutral beam enhancement currently in progress [3]. To support the development of the NBI, a dedicated experiment will be built, the Neutral Beam Test Facility (NBTF), to test the NBI at full performance before installing it at the ITER site. It will be constructed in Padova, Italy with the aim at testing the first ITER NBI from 2012 to 2016.

Neutral Beam Injector

Figure 1 shows a view of the NBI. The beam line is housed within a metallic container (Vessel). Negative ions are produced inside an ionization chamber by radio frequency (Ion source). The ions are extracted from the

Table 1: ITER vs JET neutral beam parameters

Parameter	ITER	JET
Ion	H ⁻ or D ⁻	H ⁺ or D ⁺
Beam energy	1 MeV (D ⁻)/800 keV (H ⁻)	125 keV
Beam current	40 A	65A
Pulse length	3600 s	20s
Beam divergence	< 7 mrad	---

ion source and accelerated by grids at different potential from -1MV to ground level (Accelerator). The ion beam with current up to 40A is neutralised by colliding with neutral gas of the same species in the Neutraliser. Emerging from the neutraliser will be a neutral beam (60% of the original negative ion beam) and negative and positive ion beams (each with ~ 20% of the initial power/current), all having an energy of 1 MeV. The residual ions are deflected by applying an electrostatic or magnetic field in the Residual Ion Dump onto a water-cooled collector system designed to accept the high power-density. The beam of neutral atoms is either injected into the ITER plasma or intercepted inside the injector by a movable calorimeter which can accept the full neutral beam power. To maximize ionization and avoid reionization, the injector incorporates a large cryopump to exhaust the gas that is fed into both the ion source and the neutraliser. The injector is permanently connected to the ITER primary vacuum and a fast shutter provides a low conductance between the injector and the torus except during beam injection. A high voltage bushing system carries the voltage for the grids and the active in-vessel components.

Neutral Beam Test Facility

At the ITER site, centralised auxiliary systems

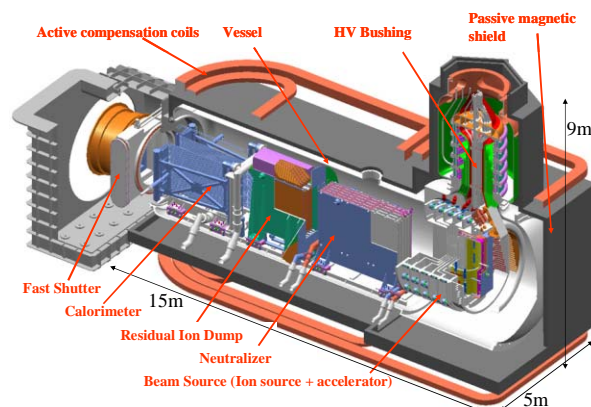

Figure 1: View of the ITER neutral beam injector.

guarantee the operation of components by providing necessary supplies such as refrigerated water for cooling, liquid He for cryogenic parts, gas flow and electric power. These services (and many other) must be present also at the NBTF to allow the exploitation of the NBI at full performance. Control, data acquisition, interlocks and safety management are important functions that must also be implemented in the NBTF. In ITER these functions are centrally provided by a macro-system including three components: the Control, Data Access and Communication system (CODAC), the Central Interlock System (CIS) and the Central Safety System [4].

SYSTEM FUNCTIONAL BREAKDOWN

The NBTF has been divided into hierarchical blocks, called systems and subsystems, including components that are functionally related. Figure 2 illustrates this subdivision. The NBTF comprises five systems:

- The NBI system, i.e. the system under test;
- The auxiliaries system including all technical services to operate the neutral beam injector;
- The control and data acquisition system (NBTF-CODAC) in charge of reliably operating the facility;
- The Central Interlock System (NBTF-CIS) in charge of machine protection;
- The Central Safety System (NBTF-CSS) in charge of protecting human beings and environment.

The NBI will be handled by NBTF-CODAC, NBTF-CIS and NBTF-CSS when installed at the test facility site, whereas ITER-CODAC, ITER-CIS and ITER-CSS will manage it when installed at the ITER site.

The components in the neutral beam injectors are grouped in five subsystems: power supply, in-vessel, diagnostics, general services and “ITER-only”. The diagnostics characterize the beam quality. When installed at the ITER site, the NBI will be completed with some additional components, like the fast shutter and the active field compensating coils which are grouped in the “ITER-only” subsystem. The NBI controller is in charge of the

NBI integrated control, whereas the Plant Interlock System (NBI-PIS) and the Plant Safety System (NBI-PSS) provide system-wide machine protection and safety functions, respectively.

The components of the auxiliaries system are grouped also into five subsystems: power grid, Ion Source Test Facility (ISTF), B-coils, diagnostics and technical services. The ISTF is a separate experiment to finalize the RF ion source in parallel to the neutral beam construction. It will be built on a faster time schedule than the neutral beam (test will start in 2010). Diagnostics in the “Auxiliaries” system will not be delivered to ITER with the injector. The B-coils are a set of coils to produce a bias magnetic field in the region of the beam line simulating the residual magnetic field of the ITER plasma. In analogy with the components in the NBI, the Auxiliaries Controller (AUX-Controller), the Plant Interlock System (NBTF-PIS) and the Plant Safety System (NBTF-PSS) are dedicated to control, system-wide machine protection and safety, respectively.

SYSTEM REQUIREMENTS

The design of NBI and NBTF is in progress and some basic choices are still under discussion. This negatively affects the reliability of non-functional requirements that can be hardly estimated and cannot be fixed yet.

Control and Data Acquisition

The pulse length of up to 3600 s requires data acquisition to be implemented as a continuous process. Most of the analogue channels will have a low sampling frequency (< 1 kHz) and only a subset will need sampling frequencies of up to a few MHz. To cope with continuous data logging, acquired data will be time stamped with absolute time. The quantity of analogue channels from the in-vessel components is limited by the reduced access through the vessel. Table 2 illustrates the current estimate of the parameters of NBTF-CODAC.

Interlock System

Due to the high power load and voltage on the in-vessel components, the interlock system is very crucial for the integrity of the installation.

Interlocks to the beam will be set in case of NBI anomalous conditions to protect the components, for instance in the presence of anomalous magnetic field in the region of the ionized beam or anomalous voltage in the residual ion dump. Interlocks to the injection of the beam will be also set by ITER in the case of inadequate plasma density or temperature in the tokamak far wall exceeding limits.

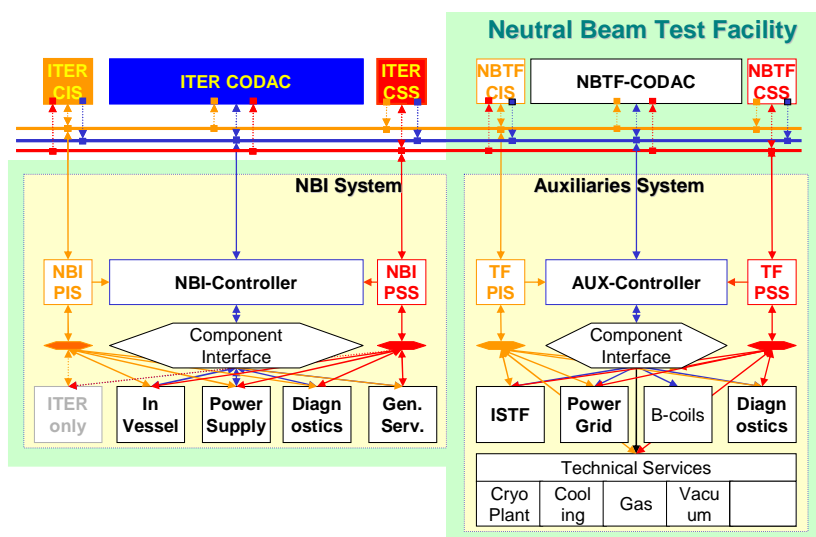

Figure 2: Functional breakdown of ITER neutral beam test facility.

Table 2: NBTF-CODAC requirements

Type	Quantity
Sampling frequency	< 5 MHz
Time resolution/precision	<200/50 ns
Nr. of input analogue ch's (NBI)	< 1000
Nr. of input analogue ch's (AUX)	< 3000
Control points	10,000 – 30,000
Data acquisition throughput	< 200 MB/s
Data acquired per pulse	< 20 GB
Data acquired in one year	< 60 TB

The NBI shutdown system must shut down the beam in a time shorter than the minimum required to produce damage to the heat receiving elements. The reference time of reaction (including detection of fault, decision and shutdown) will be shorter than 50ms for interlocks related with direct beam power deposition. Faster reaction time applies in the case of the residual ion dump voltage disappearing requiring a reaction time of < 1 ms.

Safety System

Safety is related mainly to high voltage, fire protection and radiation monitoring of both the area and release. As the NBI is connected to ITER, tritium produced in the experiment can flow from the ITER discharge chamber to the neutral beam through the fast shutter. Radiation may also be produced by the neutral beam. The safety system is to be able to reach the required level of demonstrability required by the French nuclear licensing process.

PRELIMINARY SYSTEM ARCHITECTURE

The proposed system architecture reflects the functional breakdown of the system and this will make it easier to integrate the neutral beam injector at the ITER site.

Control and Data Acquisition - Subsystem Level

Each subsystem will include a slow controller (cycle time > 10 ms), a fast controller if required (cycle time < 10 ms) and a data logger. The controllers are in charge of the reliable operation of the subsystems and will be implemented by using industrial solutions with proven high reliability. The data logger will record data according to their sampling frequency requirements and will not be responsible for reliable operation. The controllers will be implemented by using industrial solutions with proven high reliability.

Control and Data Acquisition - System Level

The NBI and AUX controllers will supervise the NBI and the Auxiliaries subsystems, respectively. They will share hardware and software technologies. The advantage of this modular approach is that cost for development and

prototyping is minimized and integration is easier. The disadvantage is that the AUX controller will use technologies prescribed by the ITER specifications for instrumentation and control and this will increase its cost.

Control and Data Acquisition – System Level

NBTF-CODAC will provide a subset of the functionalities that ITER-CODAC will provide at the ITER site. The NBTF-CODAC will be interfaced to the system level through the same communication system used by ITER-CODAC to make easier the integration of NBI and ITER-CODAC. Unfortunately the selection of the technologies for NBTF-CODAC must be done much earlier than for ITER-CODAC, with the possible result that NBTF-CODAC and ITER-CODAC might not be compatible. On the other hand, due the anticipated time schedule of the NBTF-CODAC, work in the NBTF can be considered as prototyping useful for ITER-CODAC.

Plant Interlock and Safety Systems

They will be implemented as modular, centralized blocks. NBTF-CIS and NBTF-CSS will integrate the two plant-level systems.

CONCLUSION

The functional requirements for the control, data acquisition, interlock and safety systems of the ITER NBI and NBTF have been fixed. A tentative definition has been given also for the non-functional requirements. These have to be refined with the progress of the corresponding plant system design. A functional breakdown of the two systems has been established, aiming at easing the integration with ITER CODAC. A preliminary system architecture, in correspondence with the functional breakdown, has been selected.

ACKNOWLEDGMENT

This work was supported by the European Communities under the contract of Association EURATOM/ENEA.

REFERENCES

- [1] ITER internal document, Plant Design Specification, ITER_D_22ER4F v 3.0
- [2] ITER internal document, Design Description Document (DDD5.3), Neutral Beam Heating and Current Drive (NBH&CD), ITER, N 53 DDD 29 01-07-03 R 0.1.
- [3] D. Ćirić, D.P.D. Brown, C.D. Challis, B. Chuilon, S.J. Cox, B. Crowley, I.E. Day, D.C. Edwards, G. Evison, L.J. Hackett, *et al.*, Overview of the JET neutral beam enhancement project, *Fusion Engineering and Design*, in press, Sept. 2007
- [4] Jo Lister, Jon Farthing, Martin Greenwald, Izuru Yonekawa, Status of the ITER CODAC conceptual design, this conference