

THE STATUS OF VIRGO

Franco Carbognani on behalf of the Virgo Collaboration

Abstract

The experience acquired during the commissioning phase of the VIRGO interferometer between September 2003 and August 2005 suggested some major detector up-grades to reach its design sensitivity. The detector shut down, started in September 2005 and concluded in January 2006, was devoted to the implementation of such up-grades. After the installation of a new Power Recycling mirror together with a new suspended Injection Bench, a second commissioning phase started to debug the up-grades acquiring experience in operating the interferometer for long data taking periods. To this purpose different Week-end Science Runs (WSR) have been organized to test the detector performance and its reliability as well as to prepare the transition to a long scientific data taking period (VSR1) started on May 18, 2007. In this article the main features of the VIRGO detector together with its present status and the scheduled up-grades devoted to the design sensitivity improvement, are presented.

INTRODUCTION

The VIRGO interferometer (ITF) for gravitational wave detection represents the result of an effort of two founding agencies: the CNRS for France and the INFN for Italy. It consists of a recycled Michelson ITF with two Fabry-Perot cavities along the arms 3 km long each one [1]. A passing gravitational wave impinging on the suspended mirrors is detected via a variation in the measurement of a laser beam optical path along the arms.

The VIRGO detector is located at the European Gravitational Observatory laboratory close to Cascina (Pisa – Italy) and it is designed to detect gravitational waves emitted by astrophysical sources in the frequency range between a few Hz and a few kHz. Presently, other broadband detectors, based upon to the same working principle, are active in the gravitational wave search such as the three interferometers of the LIGO Collaboration [2] and the GEO detector [3]. The great interest on gravitational wave studies is also related to the possibility that these experiments can work as network system on Earth.

THE VIRGO DETECTOR LAYOUT

The VIRGO optical layout is sketched in Figure 1. A 20 W laser beam is obtained by Nd:YVO4 high power injection laser source locked to a solid state 1 W Nd:YAG master laser. The laser beam is sent on an optical table ground connected (External Injection Bench – EIB) within the laser laboratory to be correctly aligned to the ITF reference frame before entering in the vacuum system. A large optical window separates the laser laboratory from the base tower vacuum vessel. Passing

through this window the laser beam reaches the Suspended Injection Bench (SIB) which has been redesigned adding a Faraday isolator system to reject the back-scattered light. The beam is then spatially filtered by means of 144 m long suspended triangular cavity (Input Mode Cleaner – IMC) before being injected into the main ITF. The IMC is used as a reference in the pre-stabilization loop where the laser frequency is stabilized within a few Hz by using the standard Pound-Drever-Hall technique [4]. The frequency stability below 15 Hz is achieved by an additional control loop that stabilizes the IMC length with respect to a rigid 30 cm long reference cavity (RFC) bolted on the SIB bottom part.

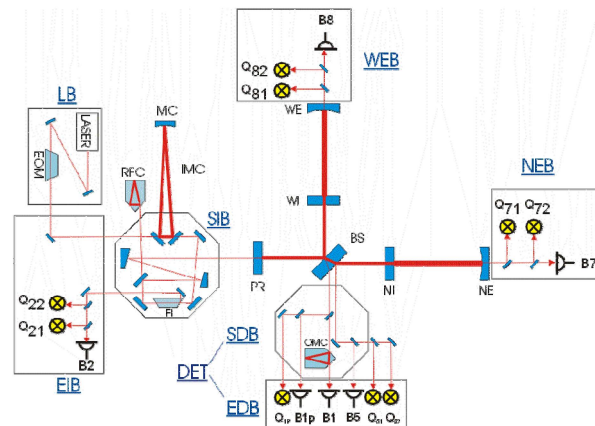

Figure 1: Virgo optical layout

The laser power available on the Power Recycling (PR) mirror is about 7 W and it is used into the ITF. Passing through the PR mirror the laser beam is separated by the Beam Splitter (BS) and finally it enters into two long Fabry-Perot cavities (North and West cavity) with a finesse of 50. They enhance the light path amplifying the beam phase change induced by the optical path length variation. Since in standard working conditions the ITF is locked on the dark fringe, all the light (apart some losses and the small amount transmitted through the terminal mirrors) sent by the injection system into the ITF is back-reflected. For this reason the high reflectivity of the PR mirror (92.2%) is used to recombine in coherent way this power and creating an additional cavity between the PR mirror and the Michelson ITF. Thanks to this technique the power impinging onto the BS mirror is amplified by a factor about 35 (recycling factor) reducing the shot noise.

All the ITF mirrors are suspended from a mechanical seismic isolation system called Superattenuator (SA). It is based on a working principle of a multistage pendulum formed by a chain with six mechanical filters hung to a three legs elastic structure conceived as a pre-isolator stage and based on a working principle of an Inverted Pendulum (IP). The SA has been conceived to provide the

required passive filtering performance of seismic noise starting from a few Hz in all degrees of freedom. An upper limit of the system has been measured during the commissioning phase obtaining an attenuation factor of 10^{15} at 10 Hz [5].

In the low frequency band (below 4 Hz) where all the resonance modes of the SA structure have been confined an active feedback control (Inertial Damping – ID) based on 3 positioning sensors and 3 accelerometers mounted on the IP top stage, is used to reduce the residual motion of the suspension point down to a few tenths of μm .

The payload suspended from the last filter chain consists of three elements: a marionette and a reference mass surrounding the mirror hung by means of two pairs of thin metallic wires in cradle configuration connected to the marionette itself. Four permanent magnets screwed to the marionette body together with the coils mounted on the legs of the last filter chain, represent the actuation system adopted to feedback control (Local Control – LC) the payload. This control system is based on optical lever sensors ground connected and it has been conceived to reduce the mirror angular motion keeping the ITF aligned within fractions of μrad r.m.s. (or better).

The shape of the reference mass has been chosen to protect the mirror and to be used as a mechanical support of the four coils mounted with cross configuration in front of four small permanent magnets glued on the mirror back side. These last actuators are used as electronic dampers to recover the position of each mirror after an ITF un-lock without exciting the mechanical mode of the filter chain.

Finally, the main output signal is reconstructed by a set of high-quantum efficiency InGaAs photodiodes mounted on an optical bench outside of the vacuum vessel (External Detection Bench – EDB). The output beam, before reaching the photodiode B1 (see Figure 1), passes through a monolithic 2.5 cm long cavity (Output Mode Cleaner – OMC) installed on a suspended bench attached to a SA and maintained in vacuum. The OMC has been included in the VIRGO optical layout to filter the higher order optical modes originating from misalignments and optical defects.

COMMISSIONING OF THE DETECTOR

The general approach adopted for the detector commissioning was that one of an increasing complexity of the optical configuration starting from the lock of a single cavity passing through a recombined mode of both cavities and finally reaching the complete ITF locking with the PR mirror aligned and the main output port on the dark fringe (recycled ITF). These results have been obtained concentrating the commissioning activity on two relevant aspects: the continuous improvements of the feedback control loops and the continuous ITF noise reduction.

To achieve the complete ITF locking, the VIRGO collaboration has developed the so called “variable finesse” technique [6] locking the ITF outside the dark fringe working point. In this way a large fraction of the

light escapes through the output port and the power built-up in the recycling cavity is low. As a last step, the ITF is brought adiabatically on the dark fringe.

Once the ITF is locked another control loop is necessary to maintain the mirrors perfectly aligned one with respect to the other and with respect to the laser beam. Since the necessary accuracy is not achievable by using the ground based LC, an automatic alignment based on the Anderson technique [7] and using the transmitted light through the end mirrors has been implemented.

One of the main difficulties found attempting the full ITF locking was due to a large amount of light backscattered into the Injection System. This problem increased the beam frequency noise making the locking acquisition very difficult. It was temporary solved by introducing an optical attenuator between the IMC and the PR mirror at the price of reducing the injected power by one order of magnitude. With the new SIB, completely redesigned and installed during the detector shut down (September 2005 – January 2006) on top of which a large Faraday Isolator has been included, the problem has been eliminated. As a consequence of the optical components choice accommodated on SIB and because of the problems put in evidence by the curved and non-monolithic PR mirror a flat monolithic PR mirror replaced the previous one. When the second commissioning phase started, the injected power into the ITF was increased and new difficulties appeared due to the mirrors thermal deformation. This required to slightly reduce the power and to re-visit the lock acquisition process to deal with the thermal transient. A mirror thermal compensation system, currently under development, should solve this problem in 2008.

The second aspect of the commissioning work dealt with the ITF noise reduction. This work consisted in the identification of noise sources limiting the ITF sensitivity. In some cases the sensitivity improvement required a fine tuning of the control systems, while a better protection of the ITF sensors from external disturbances together with environmental noise reduction helped a lot. Many of these noise sources were addressed in the last months of commissioning before VSR1. Acoustic noise source, for instance, were reduced adding isolating enclosures on in-air optical benches (EIB, EDB, WEB and NEB - see Figure 1).

All over the second commissioning period a set of Week-end Scientific Run (WSRs) with the ITF operated at high power in recycled configuration has been organized since September 2006. Those runs have been important for the final tuning of the shifts organization, automatic procedures and for checking detector reliability and data taking process before a long run. The sensitivity obtained during those runs is shown in Figure 2.

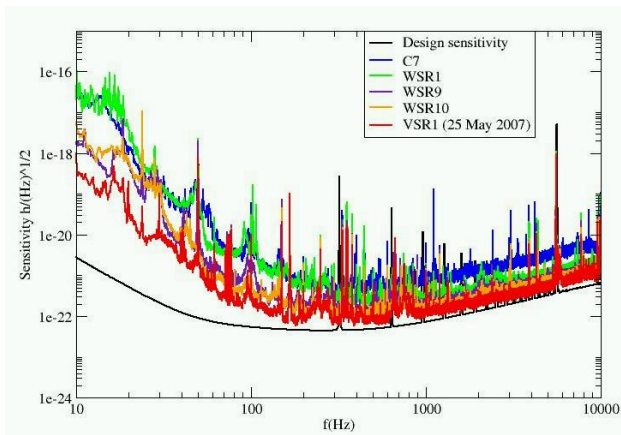

Figure 2: Virgo sensitivity curves on the different runs compared to the design one

VSR1 DETECTOR PERFORMANCE

The first VIRGO Science Run (VSR1) started on May 18th, 2007 in coincidence with the last period of LIGO S5 run. Even if the detector sensitivity was not the design one all over the bandwidth (in the frequency region 300 Hz-5 kHz the design sensitivity has been reached and it is equal to the LIGO one), it has been considered appropriate to start joint data analysis with the LIGO Scientific Collaboration (LSC). In this context a Memorandum Of Understanding (MOU) has been signed between the two scientific communities that schedules full data exchange, joint data analysis and joint publications.

In term of detector stability, the VSR1 duty-cycle achieved 81%. This result has been obtained thanks to a full locking automation procedure (see [8]) and to the recent substantial improvement of the VIRGO seismic isolation system controls. The detector sensitivity expressed in terms of the maximum distance, at which a coalescing binary formed by two neutron stars with 1.4 solar masses would be detectable, attained 4 Mpc.

THE NEXT STEPS: VIRGO+ AND ADVANCED VIRGO

The VIRGO design sensitivity will allow testing some of the present gravitational wave amplitude upper limits. Even if a first detection is possible, the sensitivity of VIRGO and LIGO detectors are not sufficient to open the era of gravitational wave astronomy. Moreover, any potential gravitational wave signal detection should be done by a coincidence of different interferometers having a common sensitivity on a large bandwidth to be considered as a network. For these reasons it is important

to prepare an up-grade of the present apparatus improving the design sensitivity of a factor 2 (VIRGO+), so that an increment of a factor 10 or more in the detection rate will be reachable.

The Italian-French collaboration is planning a first set of detector up-upgrades, VIRGO+ [9], which should be completed (commissioning included) within the first half of 2009. After this phase the detector should be ready for data taking in coincidence with enhanced LIGO (eLIGO).

Since the seismic isolation system (SA) is compliant with the design sensitivity improvement, the scheduled changes will concern:

- the installation of new IMC payload;
- the installation of a system for thermal compensation of the mirrors;
- the improvement of the output power laser (up to 50 watt) by using a new laser amplifier;
- the installation of new control system electronics;
- the installation of new mirrors increasing the Fabry-Perot cavities finesse up to 150;
- the installation of fused silica last stage suspension (still under evaluation).

A more substantial up-upgrades campaign will take place at the beginning of the next decade, when a second generation detector, called Advanced VIRGO (AdV) [10], will be installed in the present infrastructure. In this case the main goal is to improve the present design sensitivity by one order of magnitude, increasing the event rate by three orders of magnitude. The conceptual design document of AdV is expected to become available by the end of 2007. A dedicated R&D program is in progress with the goal to start the engineering phase in 2010.

REFERENCES

- [1] <http://www.virgo.infn.it>
- [2] <http://www.ligo.caltech.edu>
- [3] <http://geo600.uni-hannover.de>
- [4] R.W.P.Drever et al., Appl. Phys. B : Photophys. Laser Chem., 31, 97-105 (1983)
- [5] S. Braccini et al., Astro. Phys. 23 (2005) 557-565
- [6] L.Barsotti et al., Proceedings of the 6th Amaldi Conference
- [7] D.Z.Anderson, Appl. Opt., 23, 2944-2949 (1984)
- [8] F. Acernese et al., Proceeding of the Icalepcs, Geneva, (2005)
- [9] Acernese F, et al., Journ. Phys., 32 (2006), 223-229.
- [10] R.Flamini et al., 'Advanced Virgo White Paper', VIR-NOT-DIR-1390-30