

AUTOMATIC BEAM PROFILE MEASUREMENT FOR THE BEAM TRANSPORT LINE

Changhor Kuo, Teno Yang, K.H. Hu, C. J. Wang, Jenny Chen, Demi Lee, Kuotung Hsu,

National Synchrotron Radiation Research Center, Hsinchu 30076, Taiwan

ABSTRACT

Digital camera has been adopted for the booster, storage ring and transport-line diagnostic recently at the Taiwan Light Source. The system provides low image distortion transmission over long distance. The system is integrated with control system. Each screen monitor equip with a digital camera. These screen monitors are used for beam profile measurement and help injection condition optimization. Wider dynamic range and highly flexibility of the digital gated camera provide various functional enhancements. System configuration and present status will be summary in this report

INTRODUCTION

Imaging applications in the accelerator community are most often utilized to measure beam profile and interference fringes. The beam profile may convert form fluorescence, various optical diagnostics (SR, OTR, DR, etc.) [1]. Usually, fluorescence screen/OTR and synchrotron light source radiation monitor measures beam profile and beam size of the accelerator system in order for performance optimization, routine operation check and various beam physics studies. This tool has been useful for characterizing properties of electron beam analysis. For example, the beam emittance is calculated from the measured beam size.

The digital camera was adopt to improve functionality of the accelerator diagnostics [2,3], a major upgrade of the data acquisition and analysis system has been implemented. The main goals are to increase signal transmission quality, the dynamic range, the linearity of the profile monitor, and better supports for data analysis.

Using a fully digital camera has two major advantages over analog CCD camera. First, the A/D conversion is performed closer to the CCD/CMOS sensor, keeping the amount of electronic noise to a minimum degree. Once the digitized signal is immune to noise, we can implement long haul (10 m ~ 10^3 m) applications in accelerator researching field. Various long hops solution is supported by the IEEE1394A/B interface. Noise immunity and isolation provided by this solution must be welcome in the accelerator environment. Second, unlike analog camera systems, digital systems do not suffer from pixel jitter. Each captured pixel value corresponds to a well-defined pixel on the CCD/CMOS chip. The IEEE1394 interface is a hot swappable and self-configuring, high performance serial bus interface that is capable of 400 Mbit/sec data transmission and will be enhanced to 3.2 Gbit/s for next generation products. The interface support asynchronous (guaranteed delivery) and isochronous (guaranteed bandwidth and latency) data transfers. By using digital IEEE1394 camera system [3,4], we are able to eliminate the frame-grabber stage of processing and directly transfer data at maximum rates of 400 MB/sec. IEEE1394 general purposed CMOS cameras (Prosilica CV640, 659 x 494 4.65 μ m square pixels) [4] were chosen for screen monitor application. There is no frame grabber or additional power supply required. Frame rates of up to 30 fps can be achieved with adequate in the full image.

SYSTEM DESCRIPTION

There are 12 IEEE-1394 cameras were installed for the screen monitor of the transport line at late 2004. All of these cameras are distributed in a large area beyond copper wire can cover, three to four near-by cameras are grouped and connected to central hub by IEEE-1394B fiber link for long distance transmission. To simply cabling, multiple nearby cameras are cascading together. Only one camera is active in the cascading chain, transmission bandwidth is shared by all cameras in cascading when

system is initializing. All screen monitor are controlled by one computer. Since only one camera is used, full bus bandwidth is available for the one camera in service.

The copper cable is suffered for longer distance transmission especially near the pulse magnet power supplies. Data stream is deteriorated sharply by the operation of pulse magnets for the cameras nearby. The camera may hang and need power reset to assume its operation occasionally. After this problem was identified, the topology of the camera array has been changed slightly to ensure the reliable operation of the whole system. Camera radiation damage is similar with analog camera. Some damage pixels are observed due to radiation [2]. Thin lead enclosure is help to improve this slightly.

Based upon experience during last two years, major disadvantage of IEEE-1394 based camera are the noise immunity of form pulse magnet operation. Short cable is preferred. To simply the cabling, multiple nearby cameras are cascading together. Transmission bandwidth is share by all cameras in the cascading bus.

Several 1394 hubs are applied in this install as shown in the Figure 1. The main issues are from 1394 copper cable specification and installation environment. The standard 1394 copper cable is defined up to 5 meter. This cable length isn't enough to real situation. The cameras are divided to several groups with the hub and optical fiber transceiver in the transport line of Taiwan light source. This layout also keeps from kicker pulse magnetic field interference. This new imaging system has been operated for one year. The stability, computer analysis and image quality is good to injection beam adjust and study.

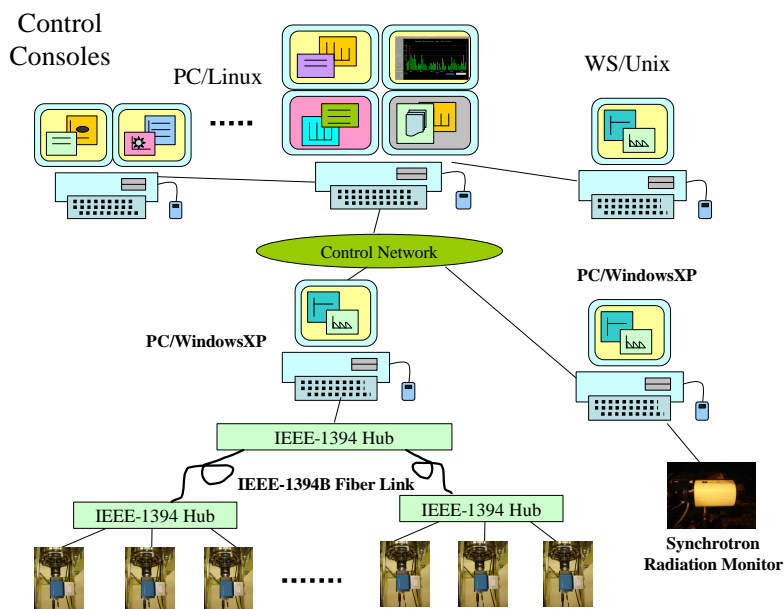

Figure 1: Topology of the IEEE-1394 camera installation.

SOFTWARE IMPLEMENTATION

Major software includes of DCAM camera drivers in the server node, user interface in the console node. The server node still contains console control function that is based on PC with windows XP. There is several functions that are necessary in the console and server node control, such as gain and exposure time control for camera, brightness control and analysis tools for demonstration. Since the camera is comply with DCAM (IIDC 1.31) digital camera standard. The protocol defines the exchange of data with IEEE 1394 cameras. However, DCAM isn't only defined in the video stream provided by the camera, but is also the camera parametric control (for instance brightness, shutter, white balance, exposure time, ...etc.). In the camera controller, we have two typical tasks - namely:

- how the camera 'tells us' which parameters it is equipped with device(for instance not every camera offers automatic gain control).
- how the parameters provided are adjusted.

These parameters are accessed via the so-called asynchronous channel of the IEEE 1394 bus. Thus, we would be able to directly access the PCs 1394 interface to exchange data with the camera. Usually we prefer interfaces at operating system level. As they clean of propriety hardware, they are basically

a standard. Indeed, they are a part of the operating system. Thus, it is not necessary to deal with the details of the DCAM specification. This DCAM driver based on windows PC is upgraded from 1.30 to 1.31 by to improve functionality which is lake in the old driver 1.30. The old driver is supported in the plug and play operation only from third party. The existent devices are automatically renamed to a new device name if there is any device is failed or disappeared in the bus. This mechanism leads uncomfortable form maintenance point of view. The new driver overcomes these problems and supported following these functions:

- Optimized YUV decompression.
- In-line Bayer decoding.
- Broadcasting - One camera can send images to multiple hosts simultaneously.
- Low level buffer management.
- Support for P4 hyper-threading machines.
- Improved camera attributes control.
- Camera enumeration function.
- Cameras plug/unplug events.
- .NET support.

The user interface in the console node is supported in the Linux and windows PC. The Matlab and Labview commercial software are applied in the on-line image analysis. The control panel (screen 3) is shown on the figure 2. The camera control includes of camera selection, gain control, trigger control, multi-exposure control, database synchronized, and the shutter control of exposure time in this tool. The image access and camera control is also support to Matlab script language. The acquire image (screen 2) and its 3 dimensional distribution as shown in Figure 3.



Figure 2: The control panel of screen monitor in the console.

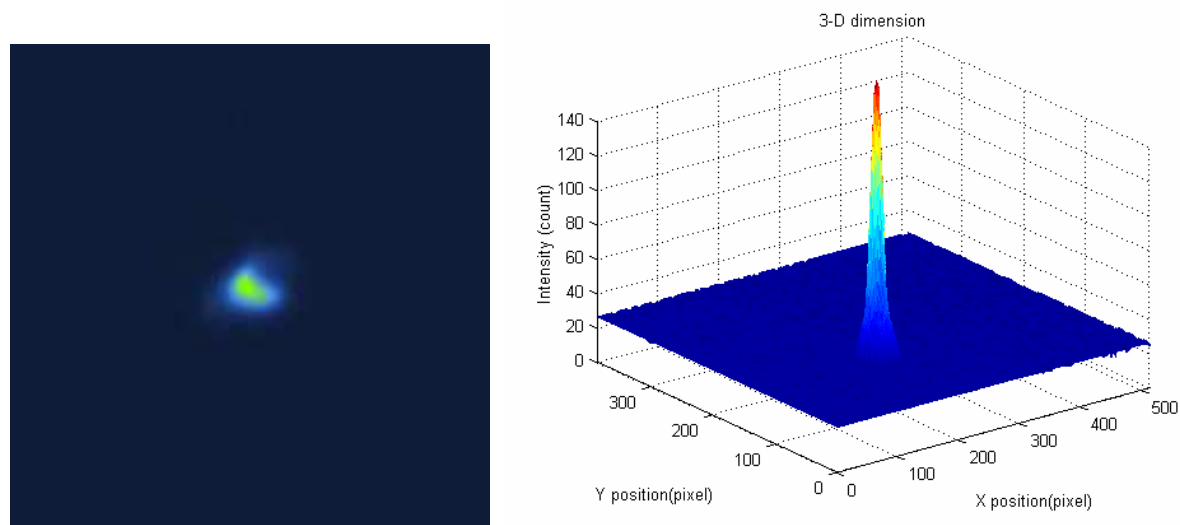

Figure 3: Raw image and its intensity distribution.

OPERATION EXPERIENCES

There are about 15 IEEE-1394 cameras were installed for the screen monitor of the transport line and storage ring. The screen monitor is installed near the injection pulse magnets of the storage ring that is interfered in the operation of these devices. The camera always hangs after a short term operation. The camera is interfered in the EM wave and ground loop noise of copper cable that is induced from pulse magnets action. We use fiber link to replace copper cable to reduce this EM wave in the cable. In other way, to cut down the 1394 cable length is necessary. That is effective to reduce ground loop noise in the cable and normally keep camera control and communication from server.

SUPPORT ANALYSIS SOFTWARE TOOLS

The image are acquire by MATLAB scripts or LabVIEW interface running at the control consoles. User can select desired screen monitor (camera) as their desires. The acquire image can be analysis by Matlab scripts further. The profoile are fitted by following formula:

$$f(x) = A + Bx + C e^{-\frac{(x-\langle x \rangle)^2}{2\langle \sigma^2 \rangle}}$$

where **A** is the baseline offset, **B** is the baseline slope, **C** : is the amplitude of the Gaussian distribution, and σ is the 1 sigma beam size. Typical analysis results is shown in the Figure 4.

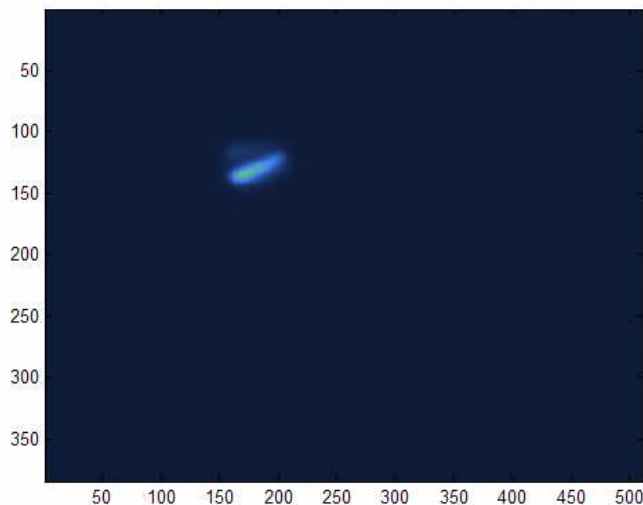

(a) Raw profile data

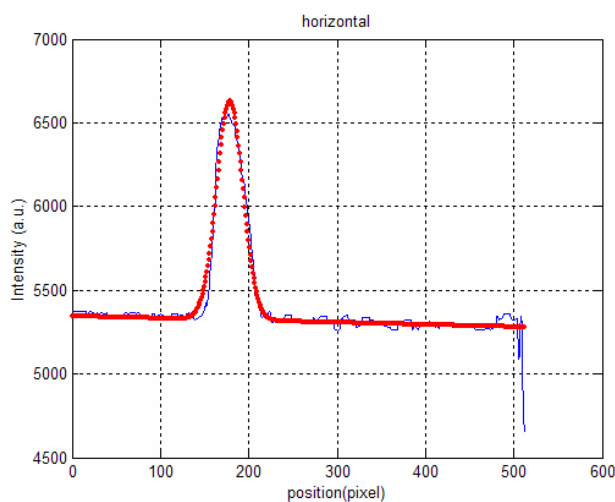

(b) Blue line is the profile data, red line is the fitted results.

Figure 3: Typical profile fitting.

APPLICATION FOR BEAM TRANSPORT LINE EMITTANCE MEASUREMENT

Since all transport line screen monitor have been upgraded to IEEE-1394 cameras. All cameras are external trigger by the extraction timing of the booster synchrotron. Adjustable exposure time is to adopt various beam intensity. Multiple exposures are possible to single bunch low charge observation. Emittance of the transport line was measured by quadrupole scan method [5]. The exposure time of the camera can be adjusted according to the beam intensity to prevent saturation of the camera. Multiple exposures are supported to measure the low beam current (single bunch). The beam image was analysed using Matlab scripts. The emittance of the extracted beam of the booster was measured by the quadrupole scan method. With a well-centered beam, the beam size can be measured as a quadratic function of the quadrupole field strength, K . The Σ_{11} -element of the beam transfer matrix is given by the following expression:

$$\begin{aligned}\Sigma_{11} &= A(K - B)^2 + C \\ &= AK^2 - 2ABK + (C + AB^2)\end{aligned}$$

with the parabolic fitting function:

$$\sum_{i1} = \langle \sigma^2 \rangle = A(K - B)^2 + C$$

Herein, A, B, and C, are the three fitting parameters, and K is the quadrupole strength. The twiss parameters can be obtained from these three fitting parameters. The emittance is given from the determinant of the beam matrix: $\varepsilon = \sqrt{AC} / S_{12}^2$. Figure 5 plots the measured horizontal beam size versus the quadrupole field strength. The fitted A, B, and C parameters are also determined. The fitted emittance is 238 nm-rad, which is consistent with the theoretical value.

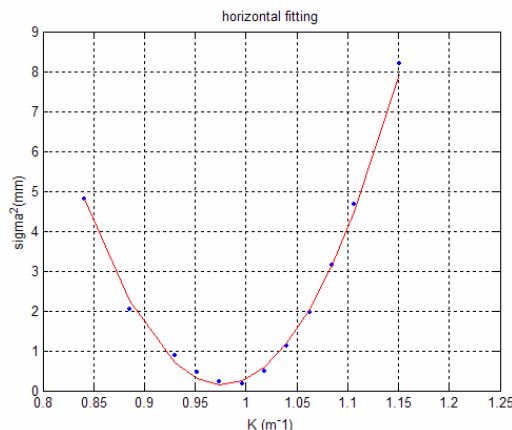

Figure 5: Example of transverse beam emittance measurements at transport line by using quadrupole scan method. Fitted parameter of A = 255.22, B = 0.98, C = 0.15, giving emittance $\varepsilon_x = 238$ nm-rad.

SUMMARY

The digital camera have been adopt for accelerator diagnostics in the NSRRC. A simple hardware topology approved acceptable reliability. However, reliability should be improved. Support of better image analysis environment is on-going. However, after screen monitor image is digitalized and record, that is helpful to up injection efficiency and top-up mode injecting operation, for especially.

REFERENCES

- [1] M. Ferianis, "Optical Techniques in Beam Diagnostics", Proceeding of the EPAC'98 and reference therein, 1998, pp. 159-163.
- [2] C. J. Wang, et. al., AIP Conf. Proc. 732 (2004) 462.
- [3] G. Rehm, AIP Conf. Proc. 732 (2004) 407.
- [4] L. Catani, et al., "A Large Distributed Digital Camera System for Accelerator Beam Diagnostics". Review of Sci. Instrum. 76, 073303 (2005).
- [5] M.G. Minty, F. Zimmermann, "Measurement and Control of Charged Particle Beams", Springer-Verlag, Berlin, Heidelberg, New York, 2003.