

High-resolution, low-latency, bunch-by-bunch feedback systems for nanobeam production and stabilisation

Philip Burrows

*John Adams Institute for Accelerator Science,
Oxford University*

Feedback On Nanosecond Timescales (FONT) Group:

Robert Apsimon, Neven Blaskovic Kraljevic, Douglas Bett, Ryan Bodenstein, Talitha Bromwich, Philip Burrows, Glenn Christian, Christine Clarke, Ben Constance, Michael Davis, Tony Hartin, Young Im Kim, Simon Jolly, Steve Molloy, Gavin Nesom, Colin Perry, Rebecca Ramjiawan, Javier Resta Lopez, Jack Roberts, Christina Swinson

Outline

- Brief introduction and motivation
- Linear collider interaction point collision feedback
- ATF2 γ - γ' feedback system
- ATF2 'interaction point' feedback system
- Summary + conclusions

International Linear Collider

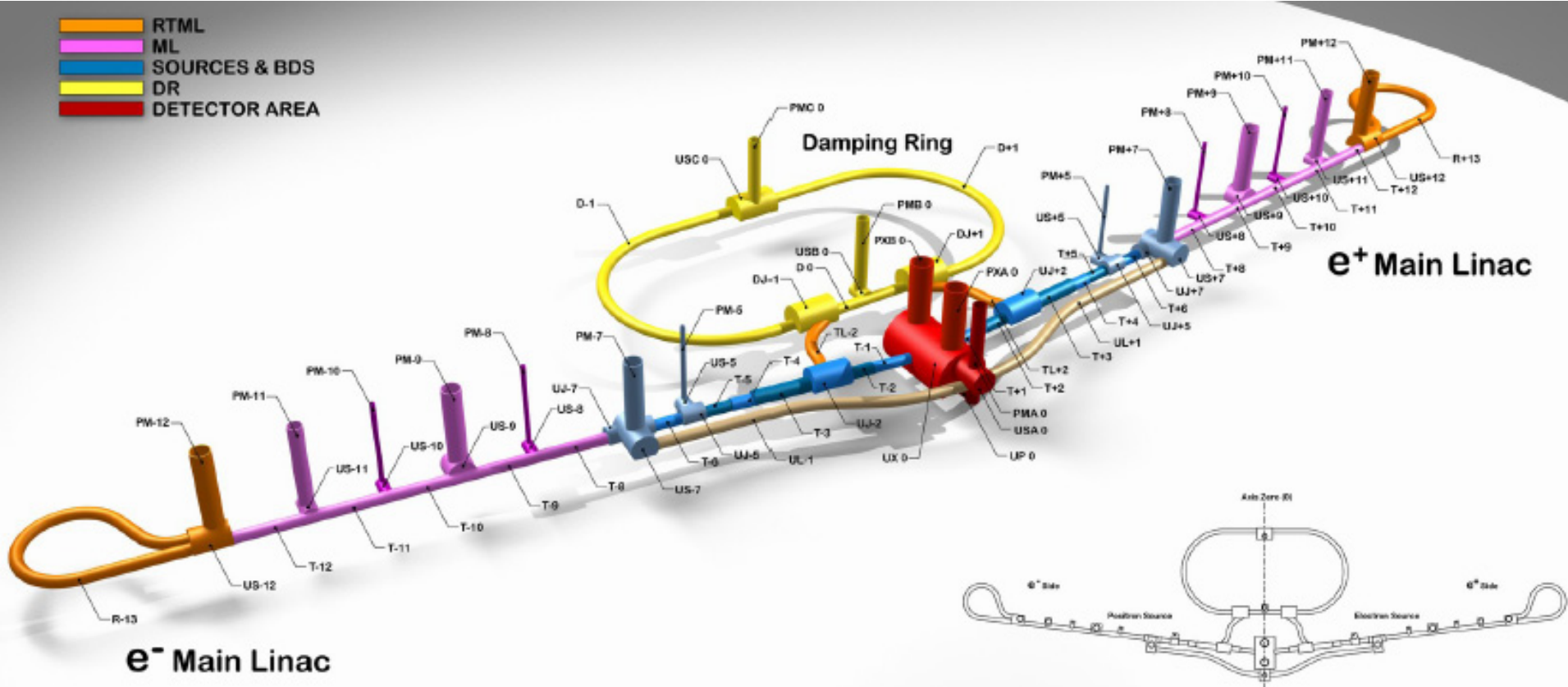

ILC beam parameters (250 GeV)

Electrons/bunch	2	10**10
Bunches/train	1312	
Bunch separation	554	ns
Train length	727	us
Train repetition rate	5	Hz
Horizontal IP beam size	516	nm
Vertical IP beam size	8	nm
Luminosity	1.4	10**34

ILC beam parameters (250 GeV)

Electrons/bunch	2	10^{10}
Bunches/train	1312	
Bunch separation	554	ns
Train length	727	us
Train repetition rate	5	Hz
Horizontal IP beam size	516	nm
Vertical IP beam size	8	nm
Luminosity	1.4	10^{34}

Collision feedback concept

Last line of defence
against relative
beam misalignment

Measure vertical
position of outgoing
beam and hence
beam-beam kick
angle

Use fast amplifier and
kicker to correct
vertical position of
incoming beam

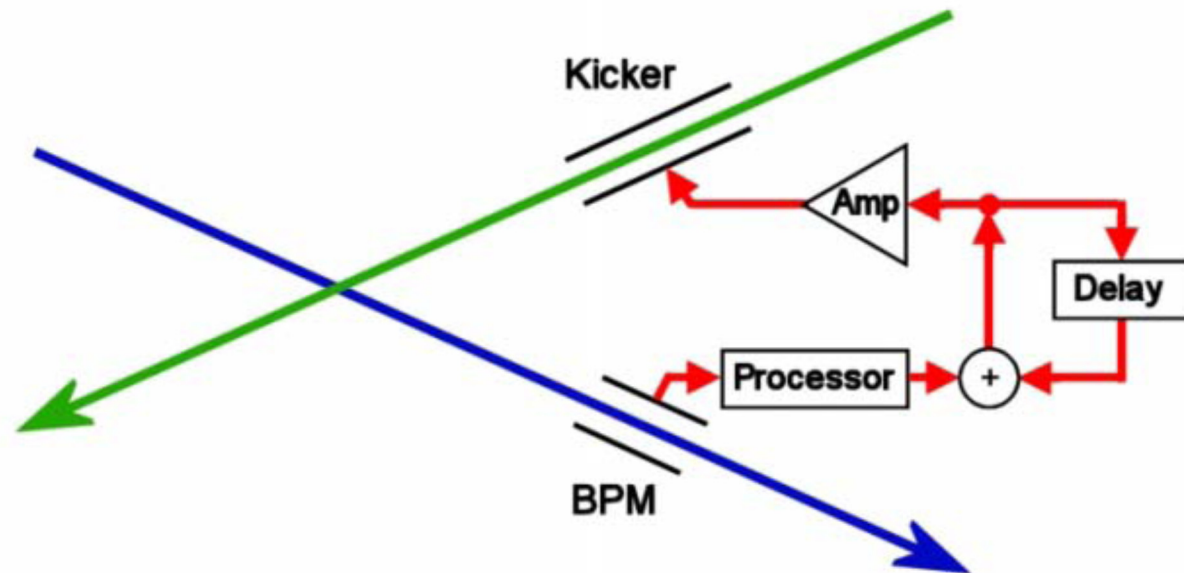

ILC Interaction Region (SiD detector)

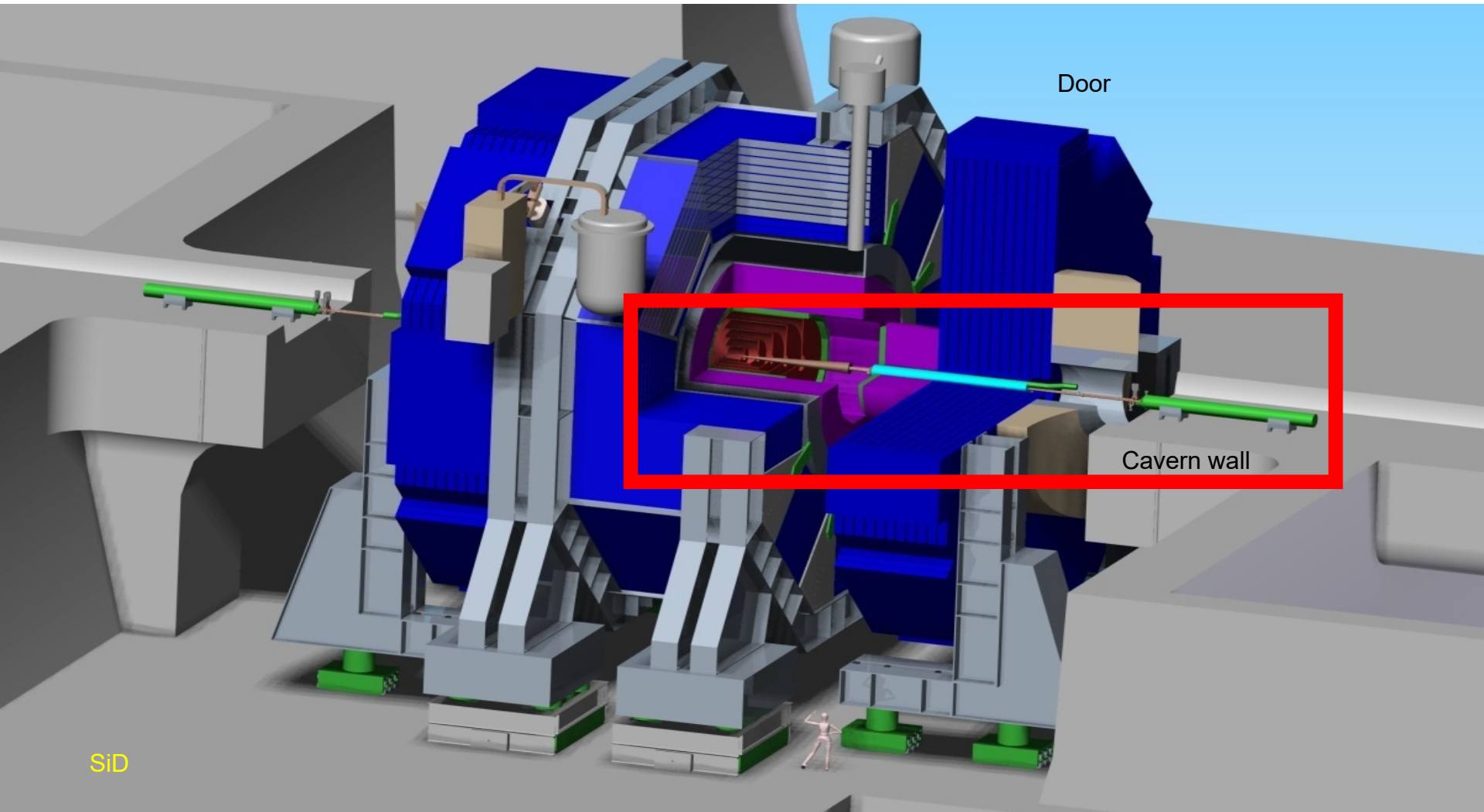

ILC final-focus region

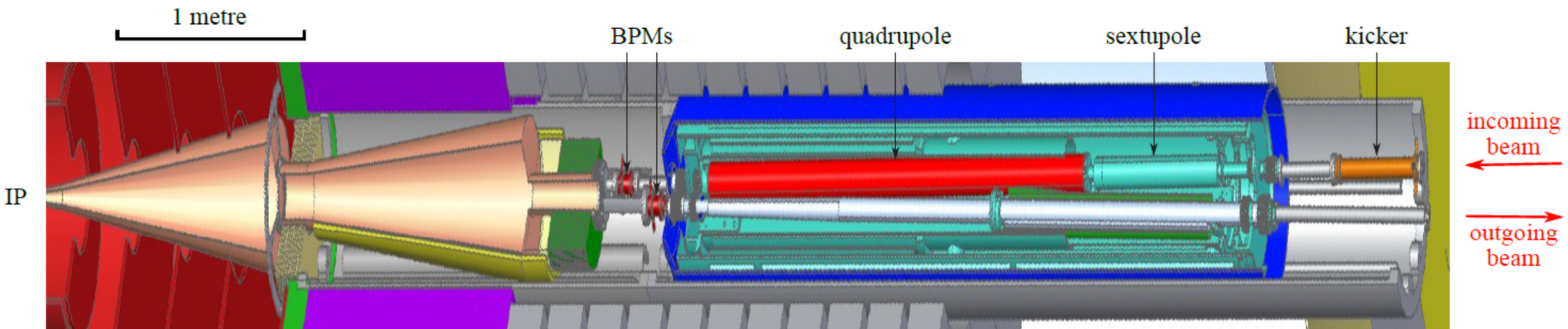

ILC final-focus region

feedback kicker on incoming beamline

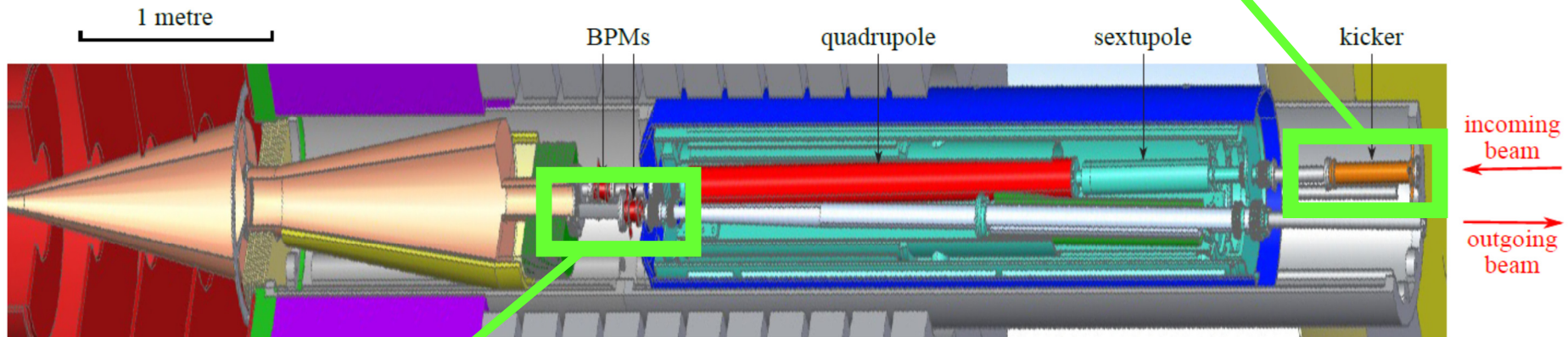

feedback BPM on outgoing beamline

KEK Accelerator Test Facility (ATF)

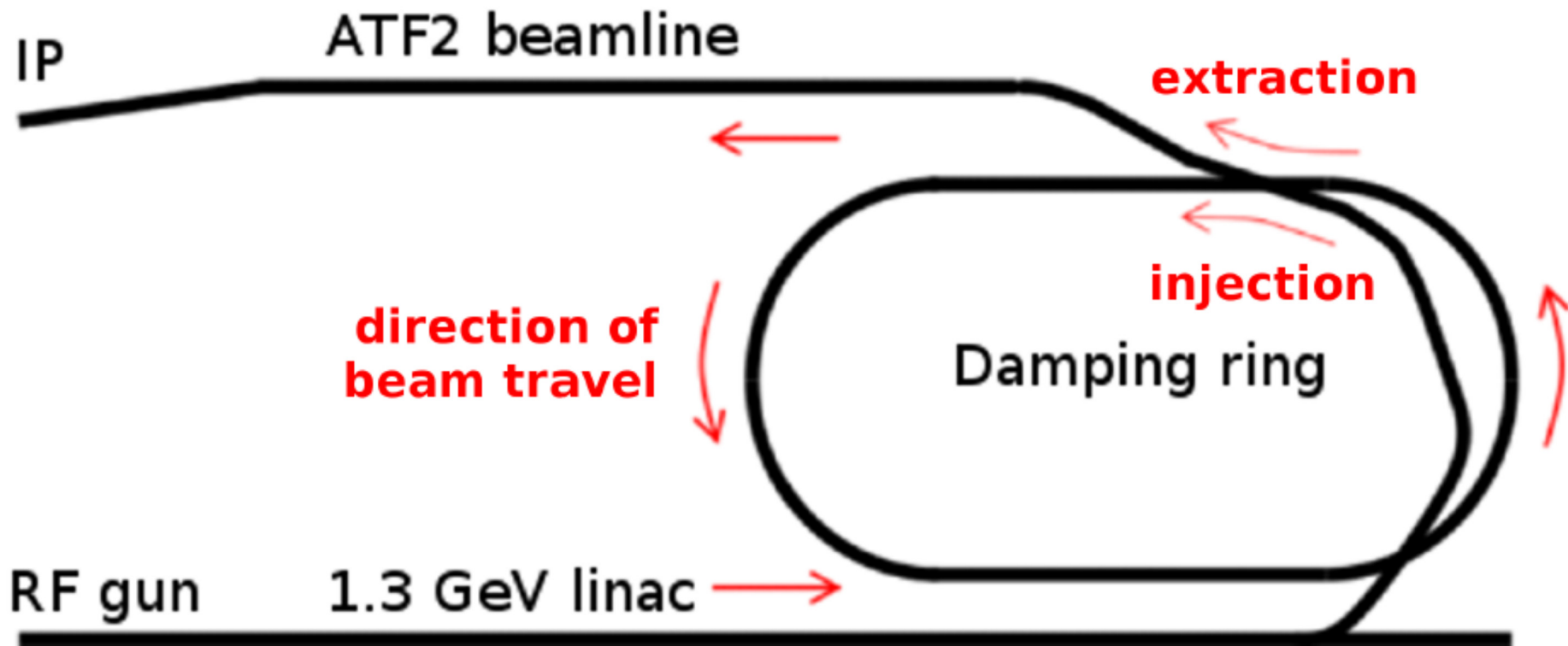

FONT installation at ATF

IP FB system

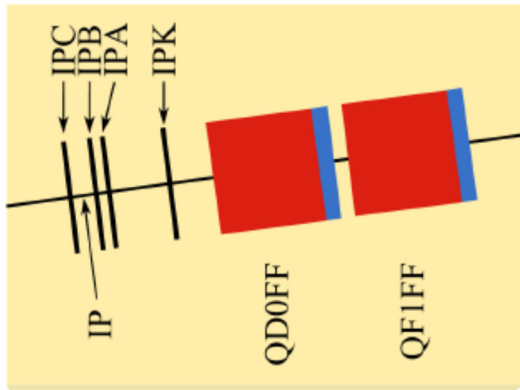

Upstream FB system

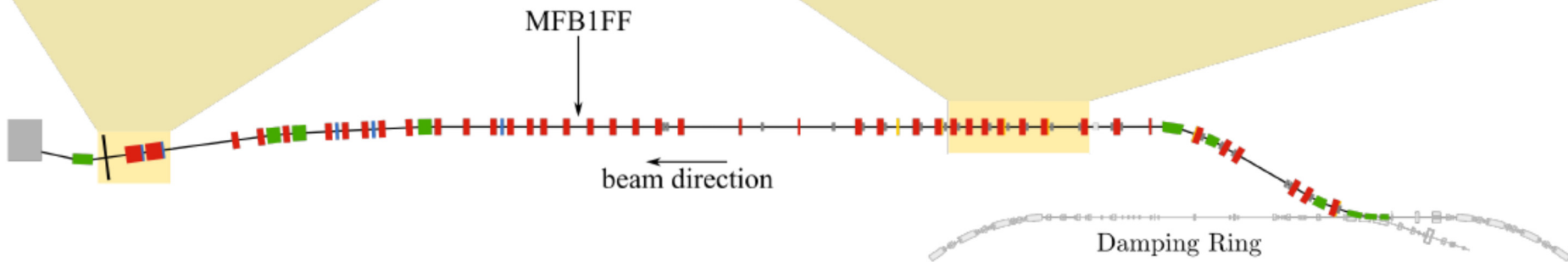
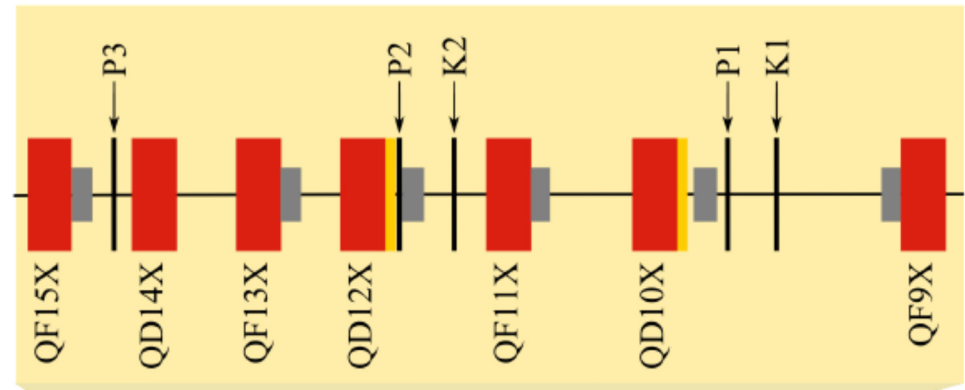

- Quadrupole
- Sextupole
- Dipole
- Skew Quadrupole
- Corrector

ILC IP FB prototype: FONT4 at ATF2

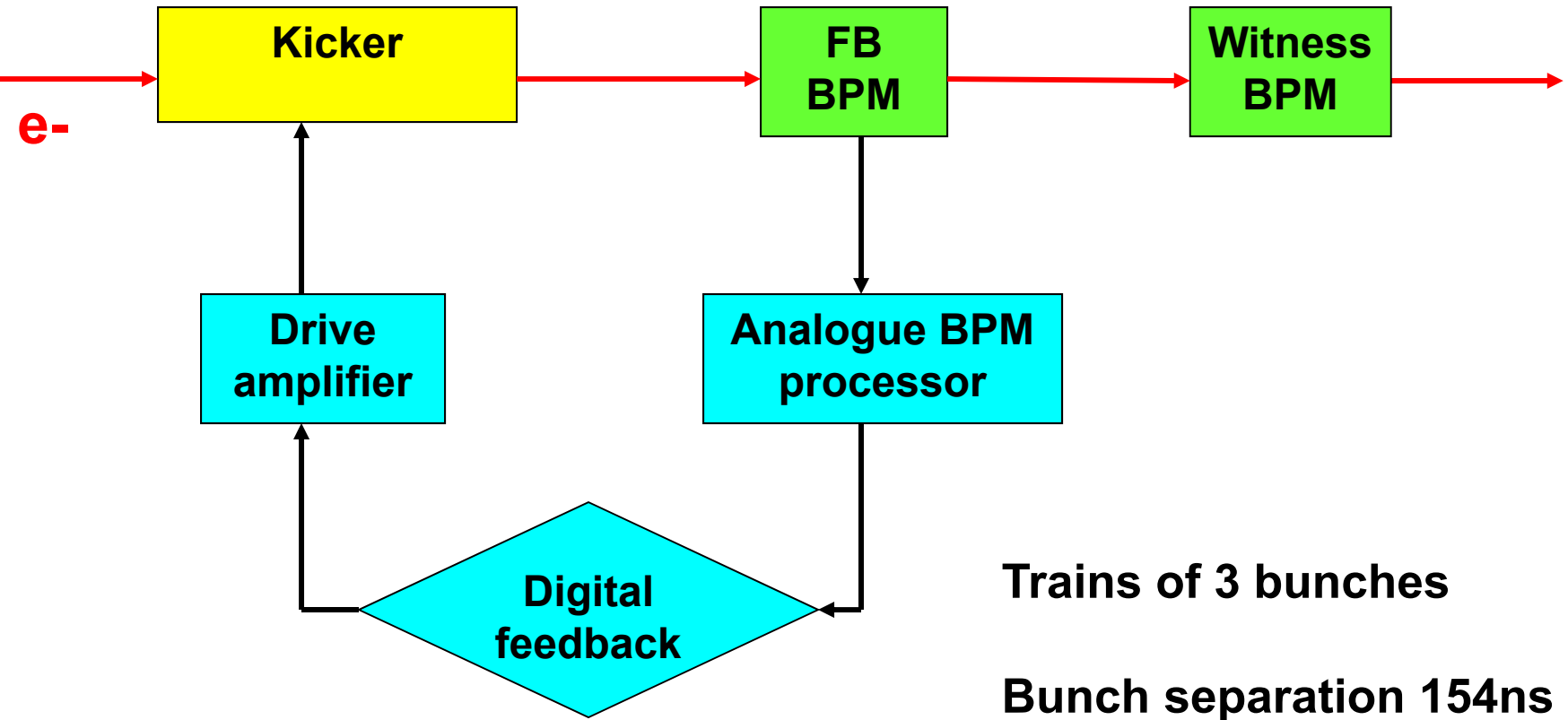

ILC IP FB prototype: FONT4 at ATF2

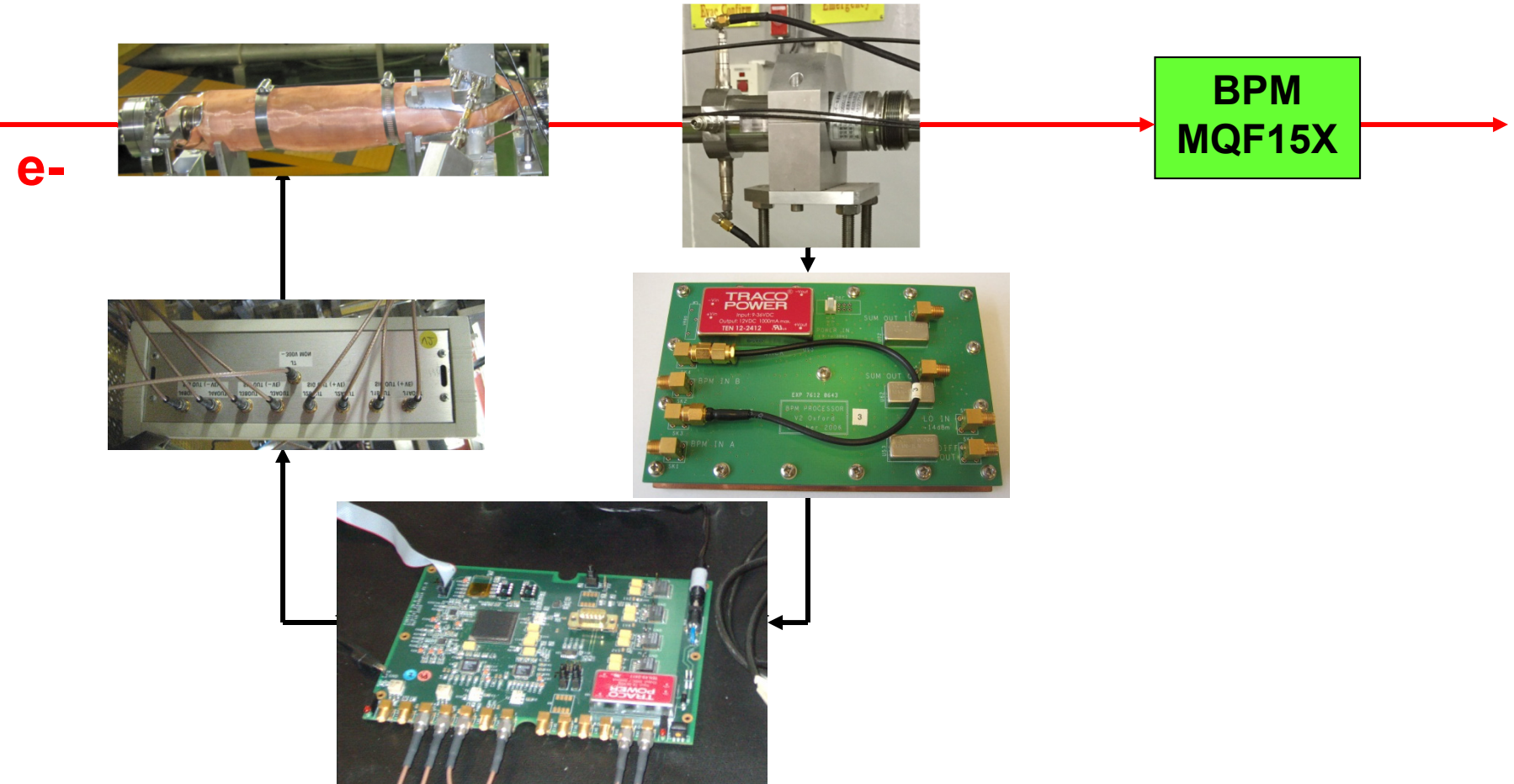

Stripline BPM signal processing

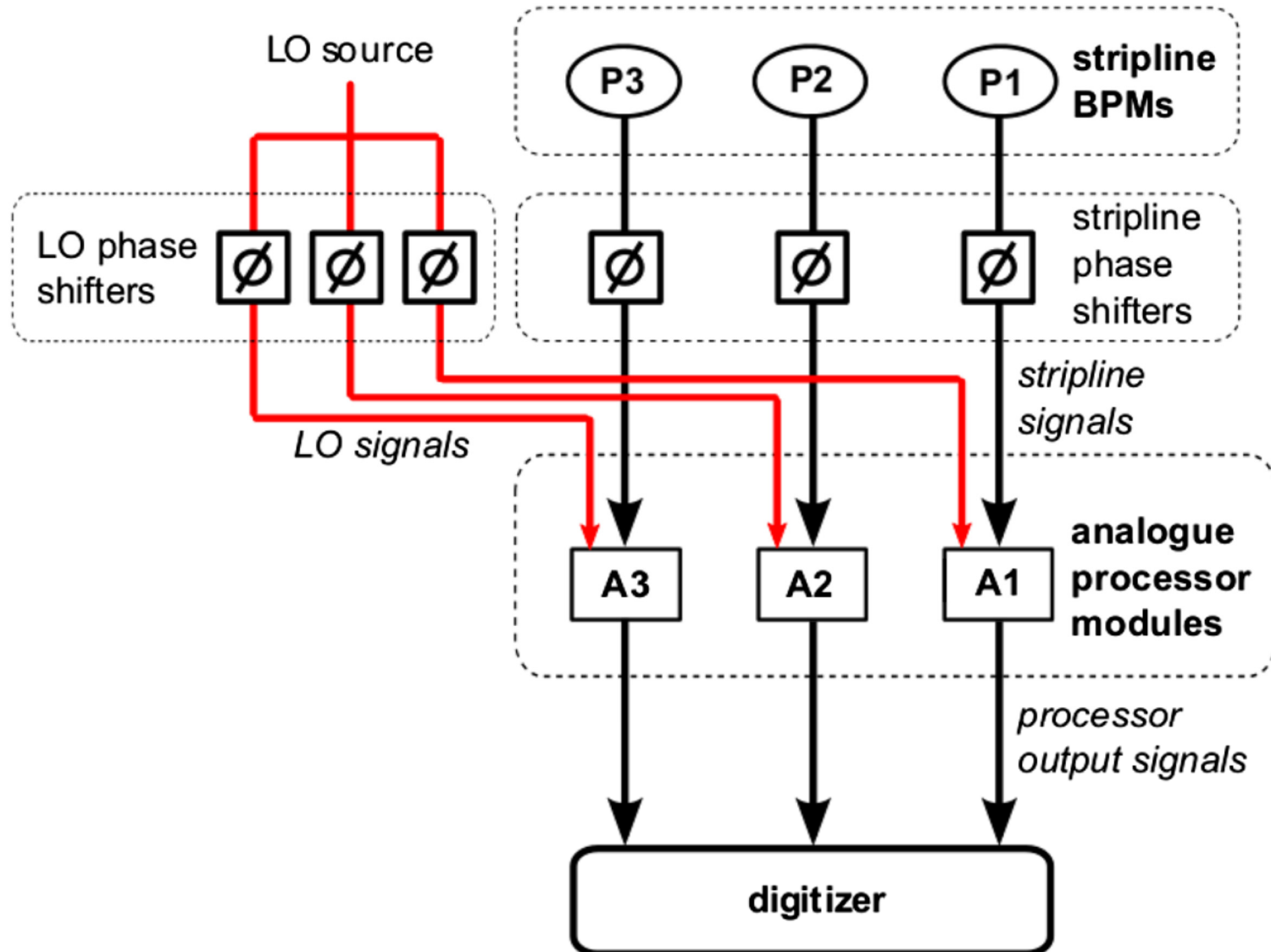

Analogue signal processor

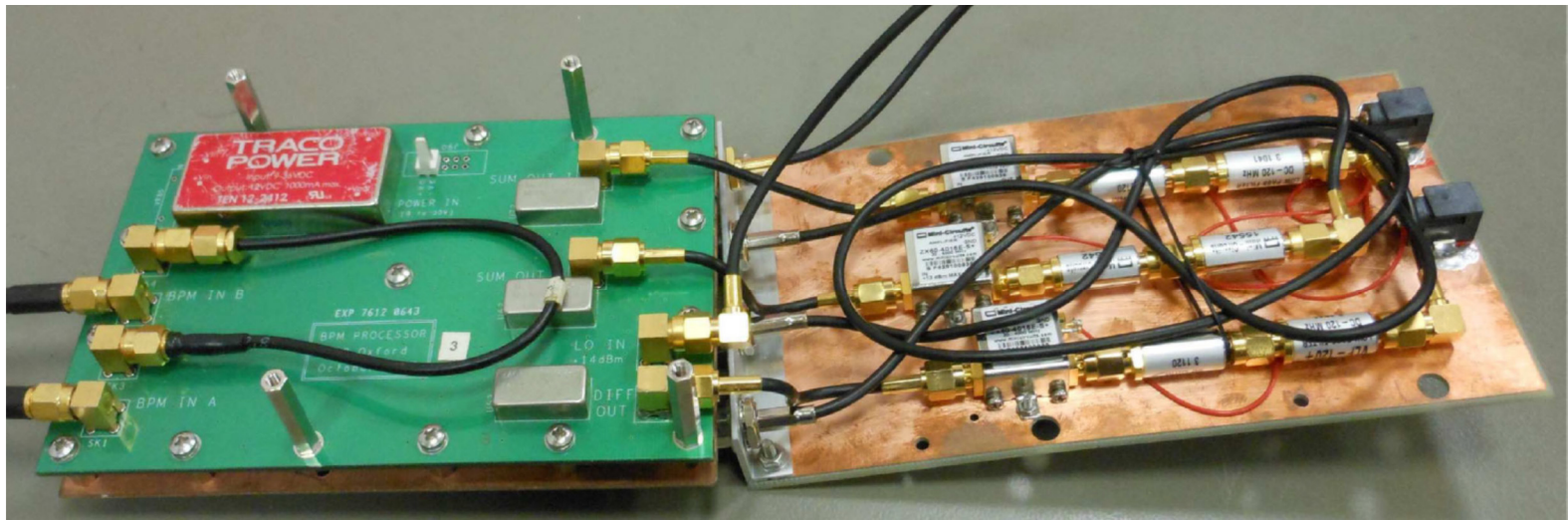
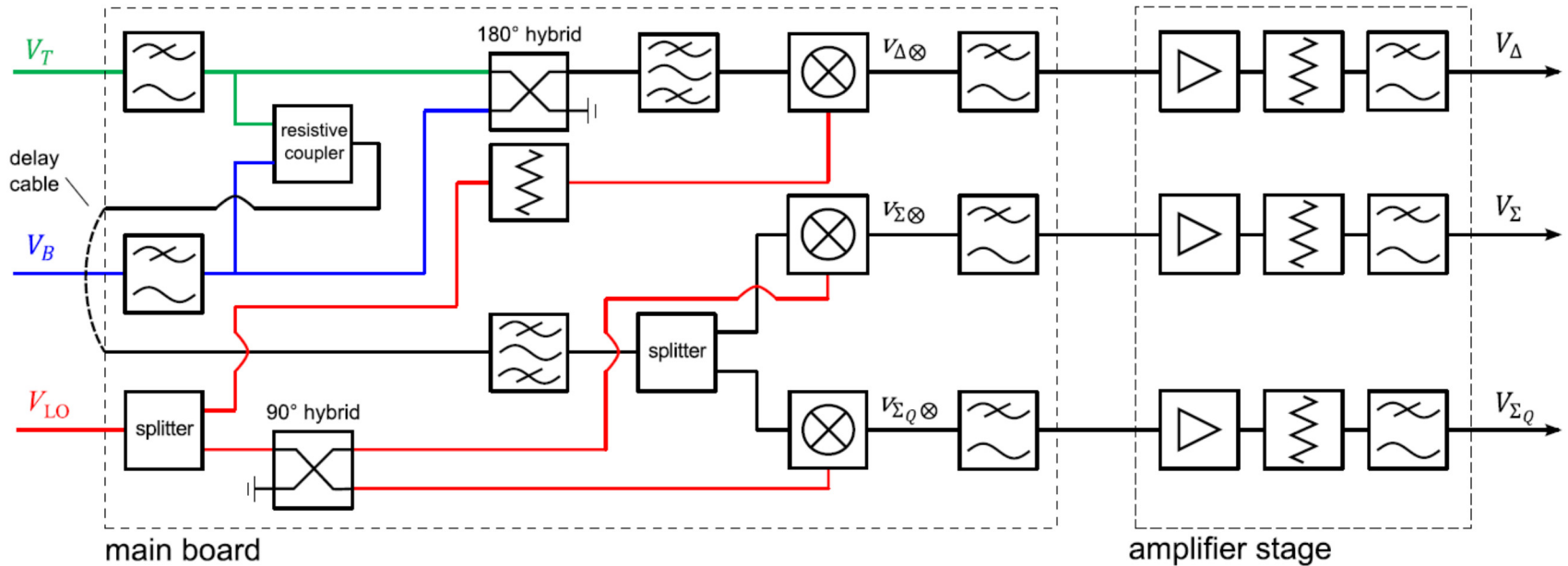

FONT4 digital feedback board

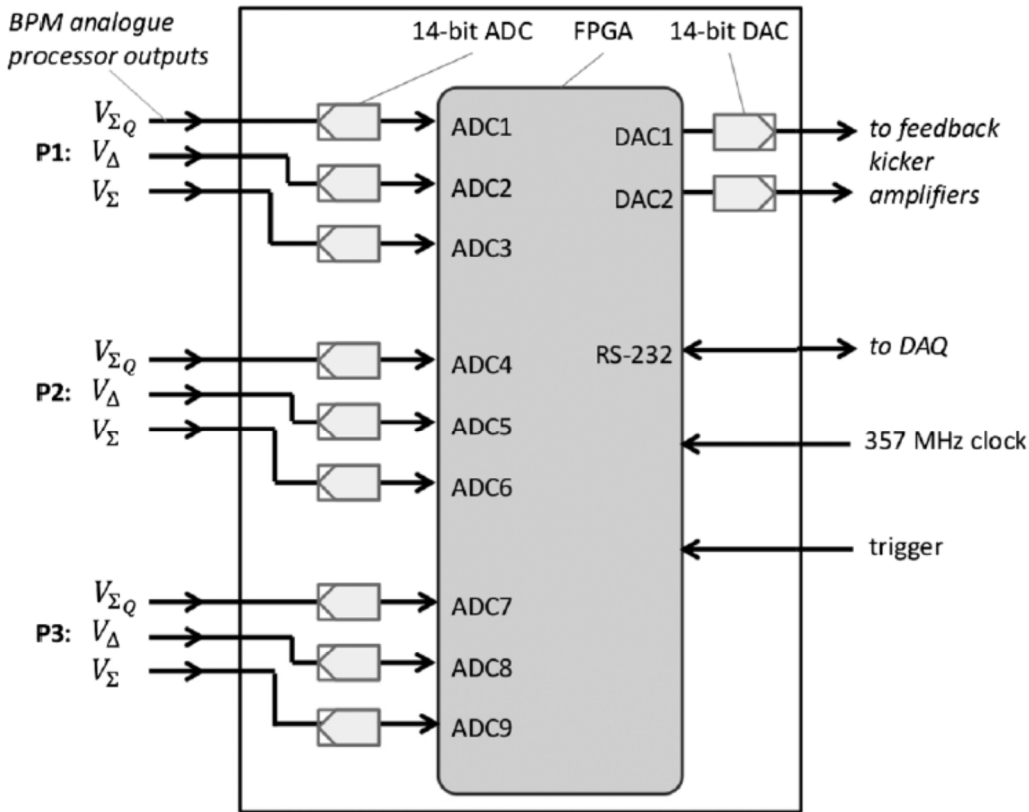

Difference/sum calculated in real time

Kicker calibration applied

Feedback gain applied

Integrator maintains running correction

Kicker drive signal(s) generated

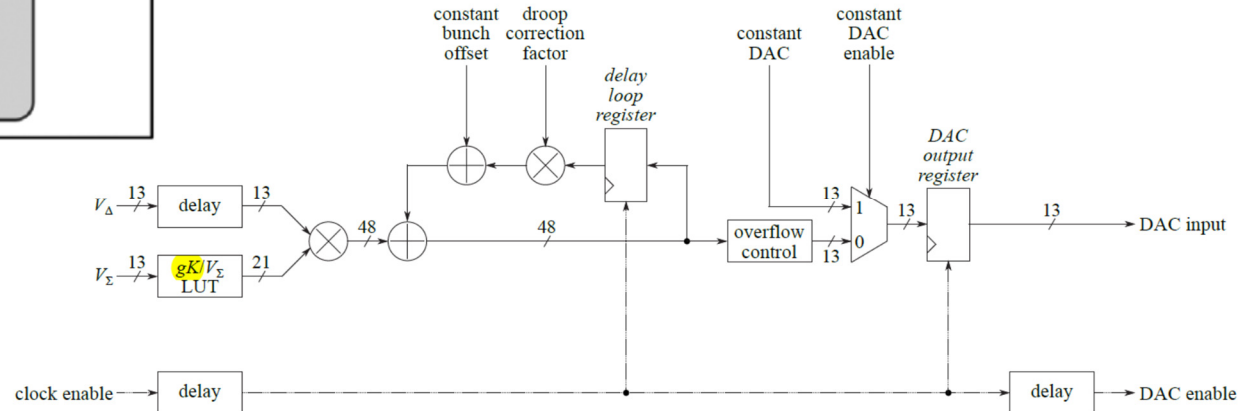

Measured BPM resolution

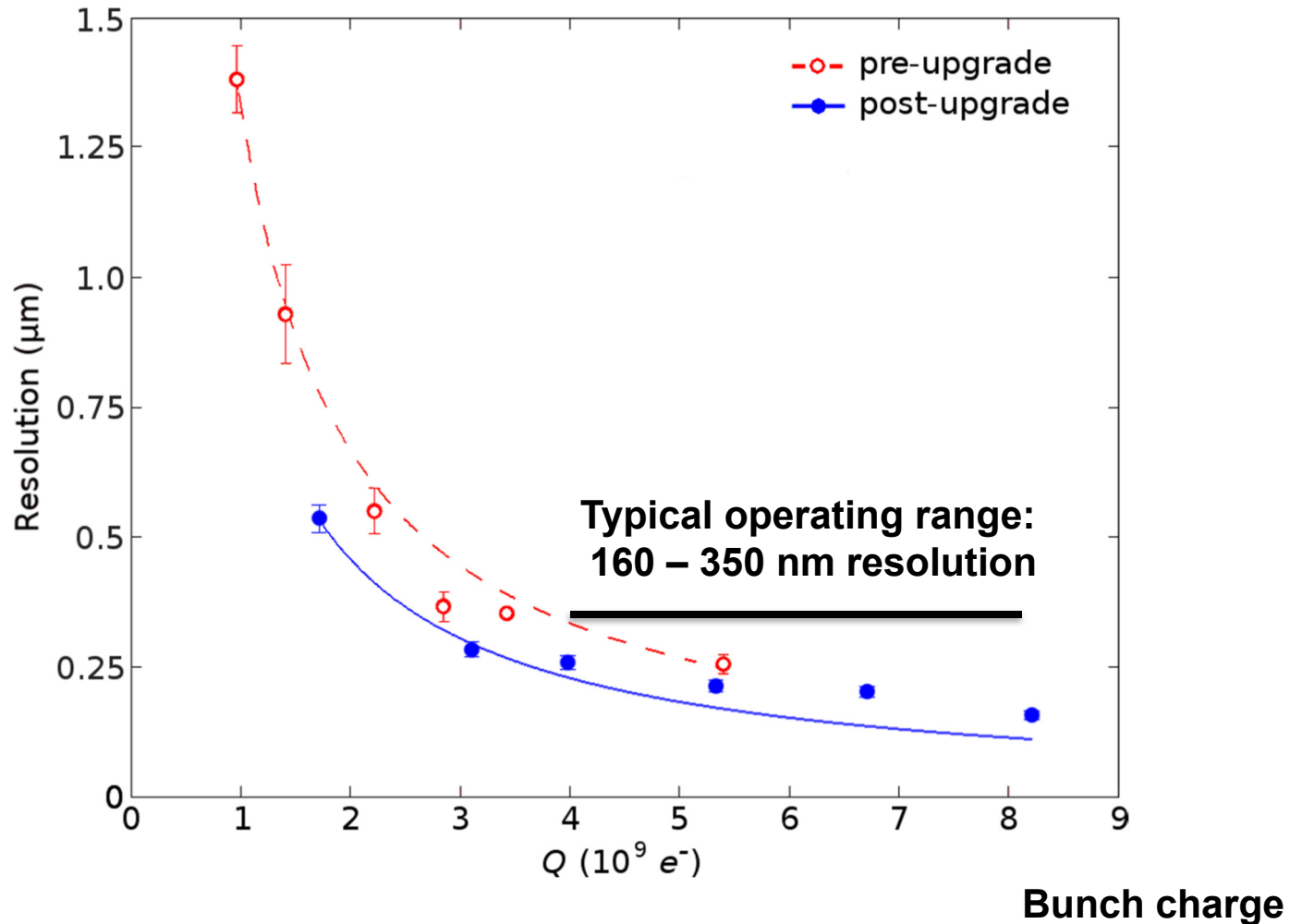

Feedback performance

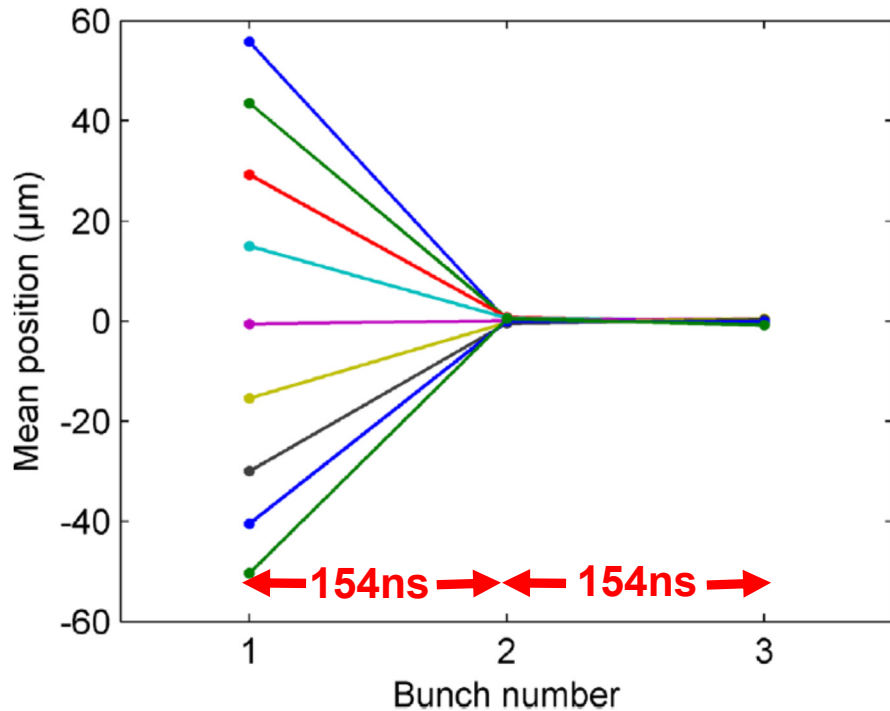

Beam position zeroed

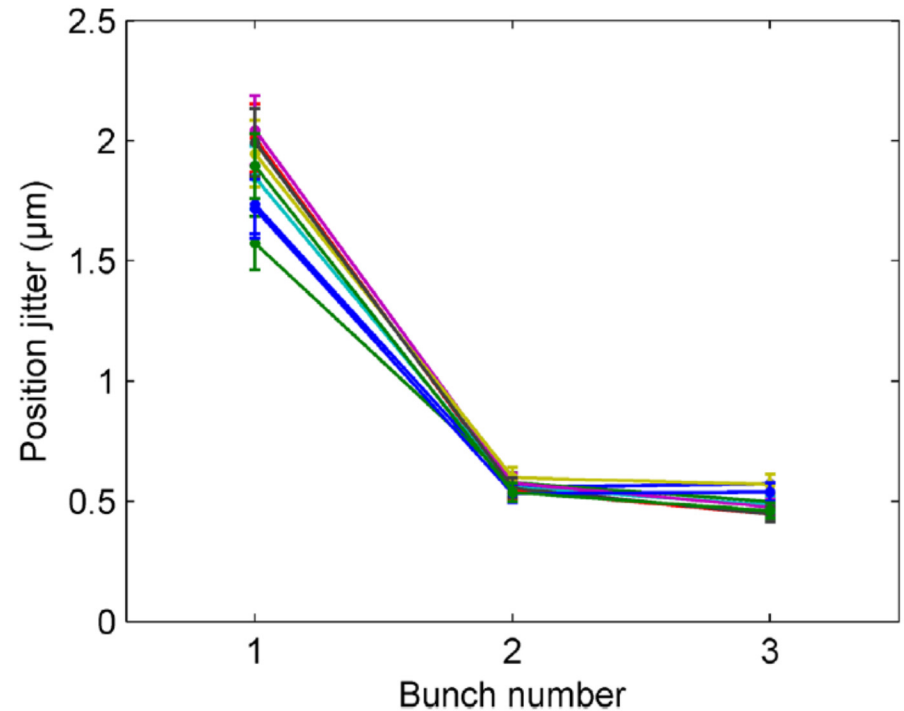

Jitter reduced to limit set by BPM resolution

Feedback performance

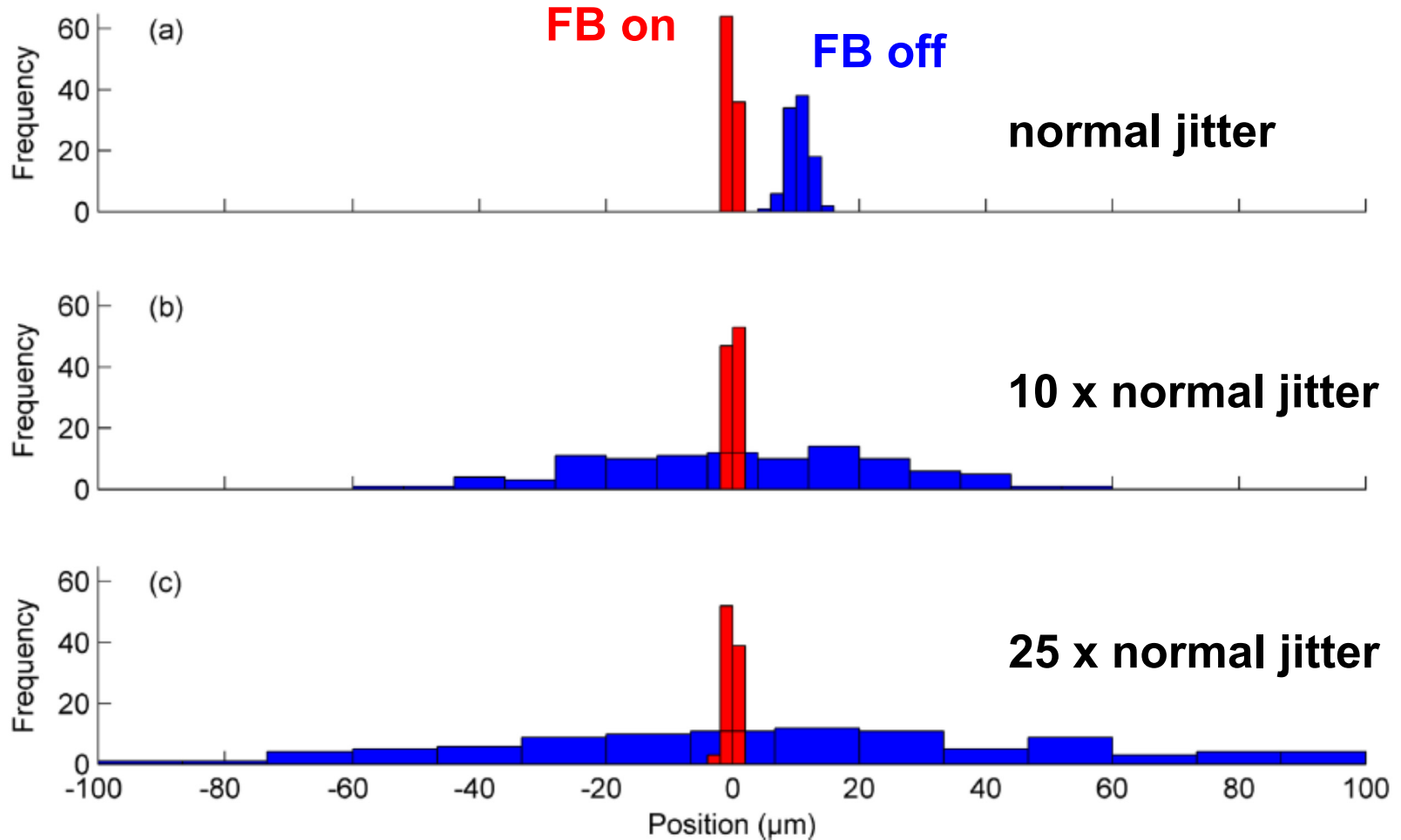

FIG. 19. Distributions of positions with feedback off (blue) and feedback on (red) for bunch 2 at P3 with incoming, uncorrected position jitters of (a) $\sim 2 \mu\text{m}$, (b) $\sim 22 \mu\text{m}$, and (c) $\sim 45 \mu\text{m}$.

FONT4 performance summary

TABLE IV. Comparison of the IP feedback performance required at the ILC with that achieved by the FONT feedback system at ATF.

		ILC	ATF
Energy per beam	GeV	250	1.3
IP feedback latency	ns	554	148
BPM dynamic range	μm	± 1400	± 1500
BPM resolution	μm	~ 50	~ 1
Beam angle correction range	nrad	$\sim \pm 60$	$\sim \pm 180^\dagger$

[†] scaled by the ATF/ILC beam energy ratio

Simulated ILC IP FB performance

(500 GeV)

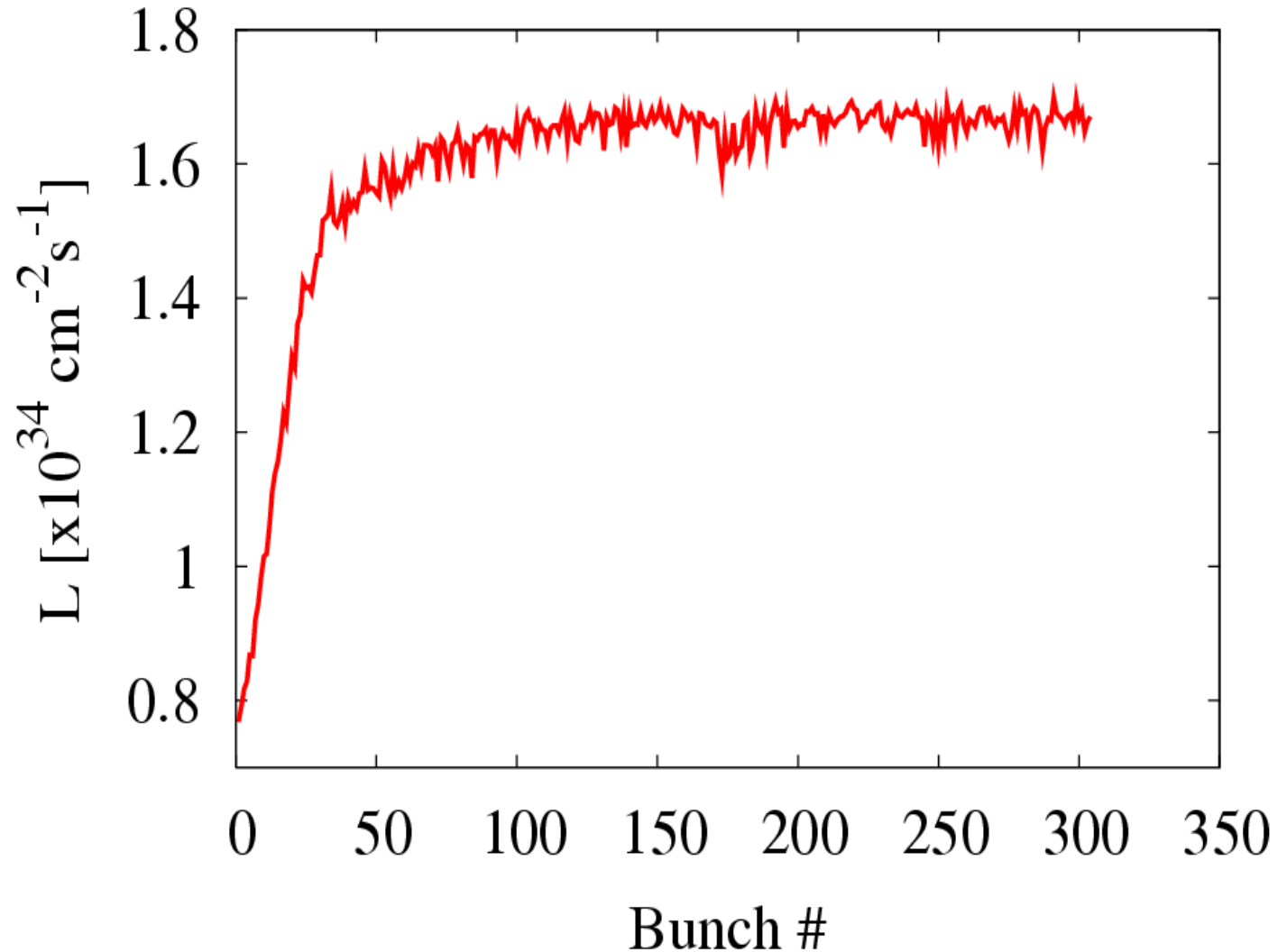

FONT5 installation at ATF2

IP FB system

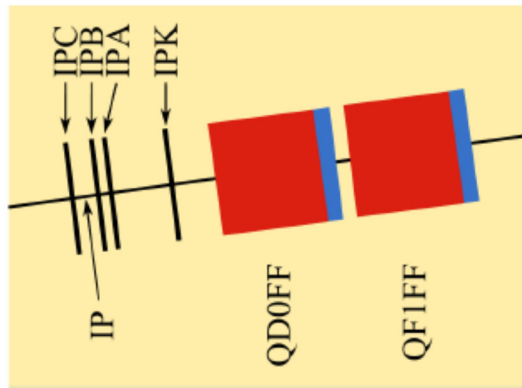

Upstream y-y' FB system

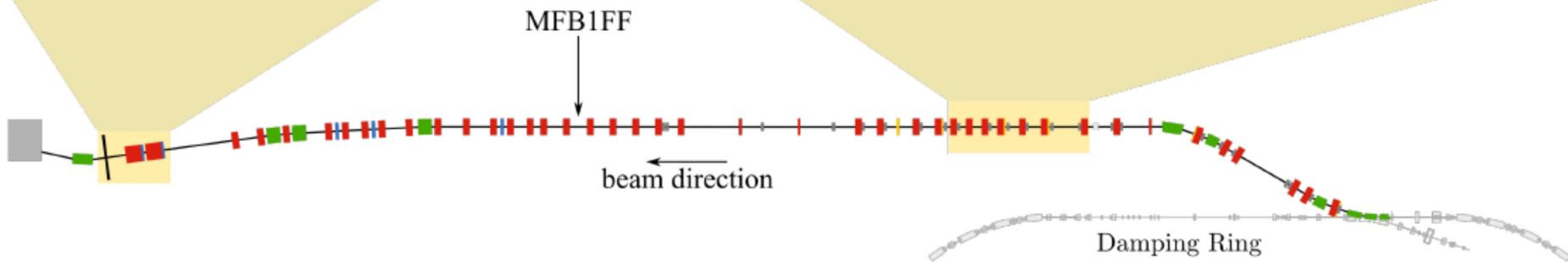
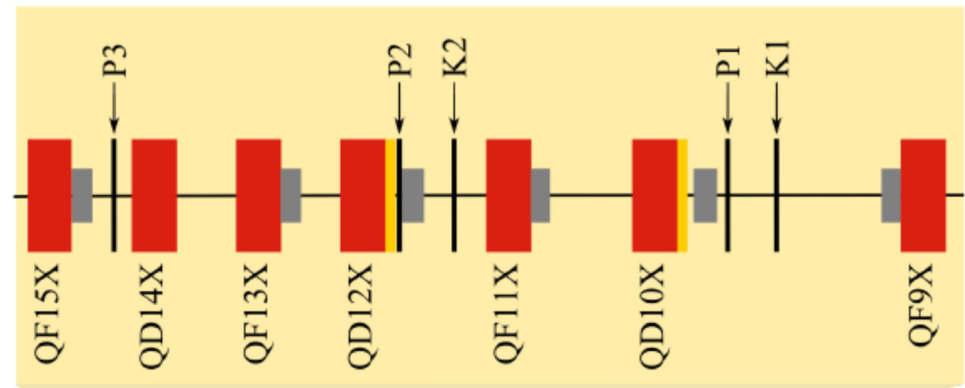

- Quadrupole
- Sextupole
- Dipole
- Skew Quadrupole
- Corrector

Upstream y-y' FB system

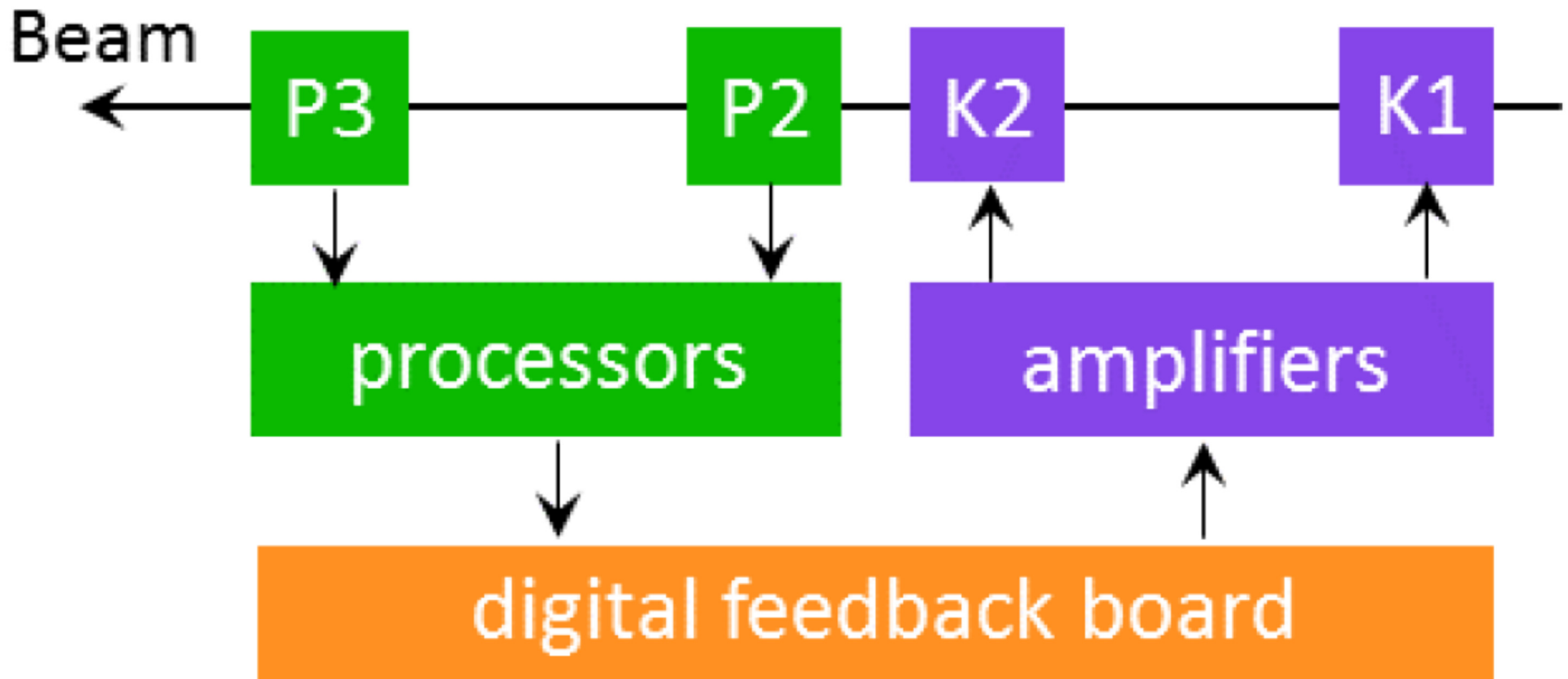

In-loop BPMs

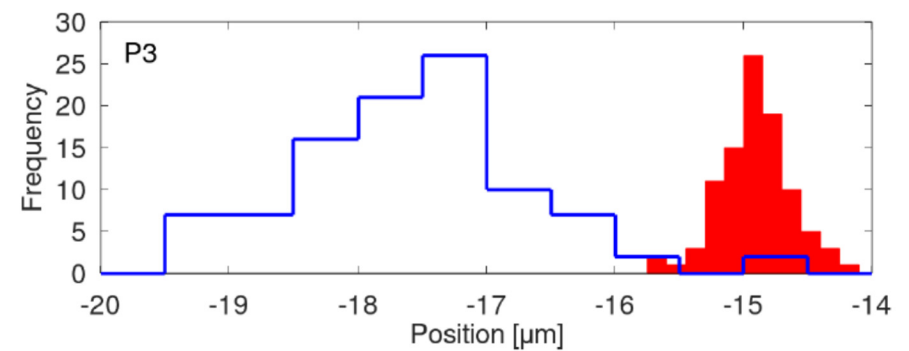
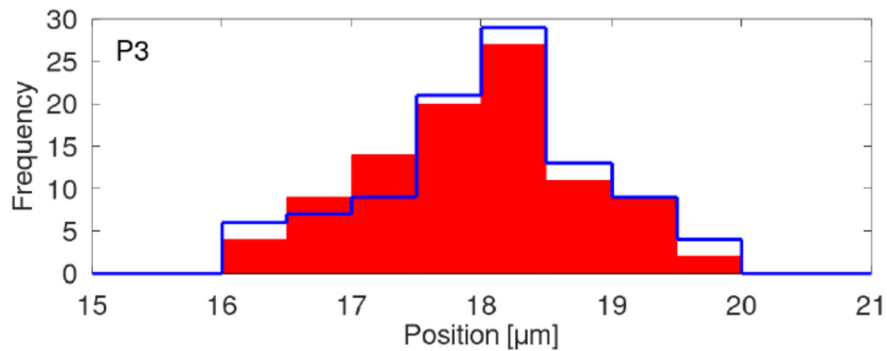
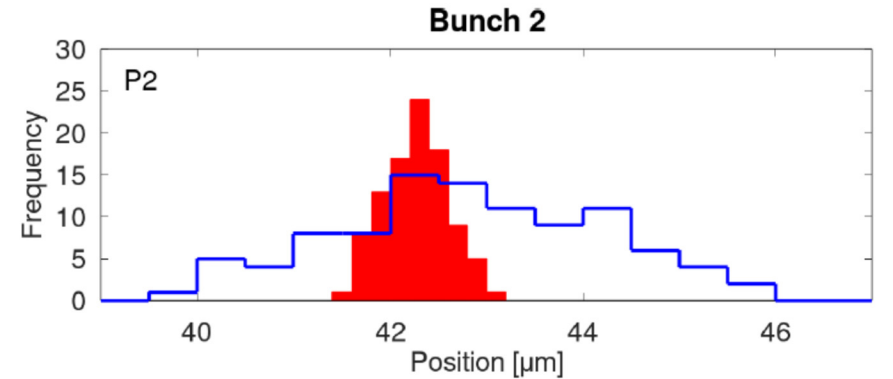
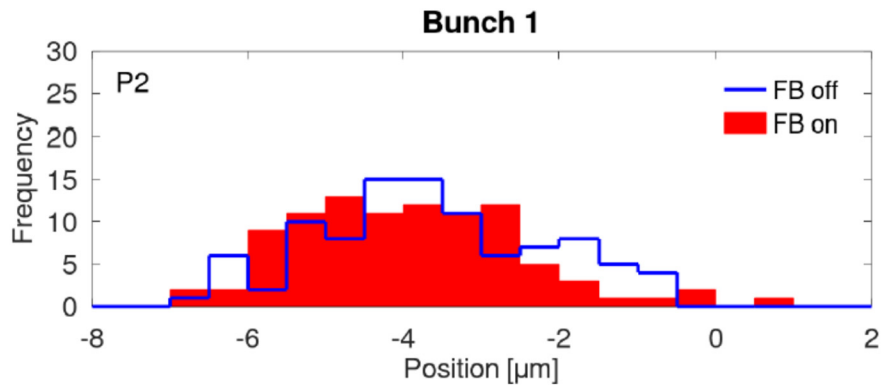

Jitter reduced by factor ~ 4 , to BPM resolution ($\sim 200\text{nm}$) limit

Downstream witness BPMs

Jitter reduced by factor ~ 4 at IP

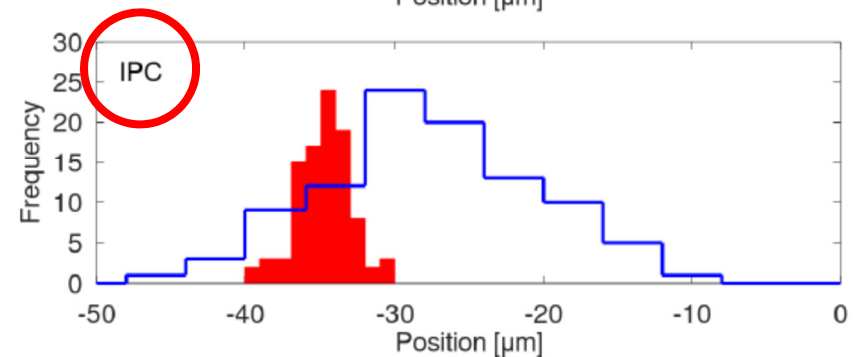
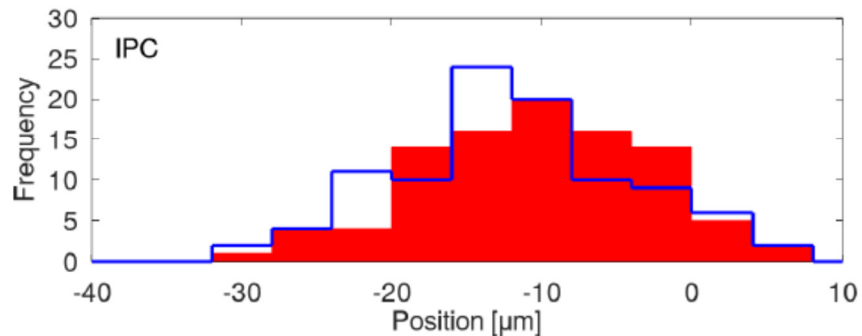
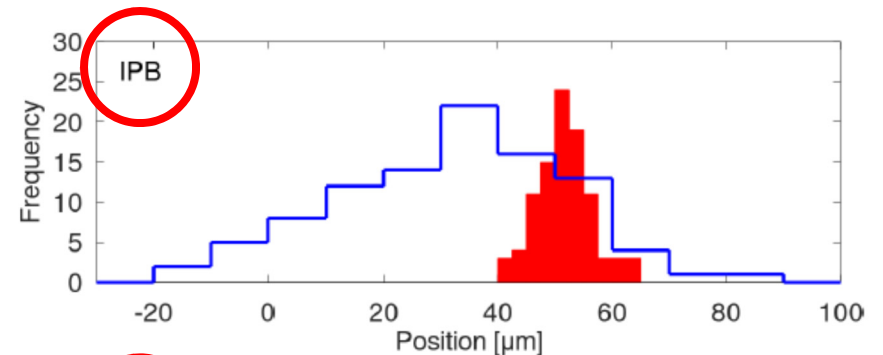
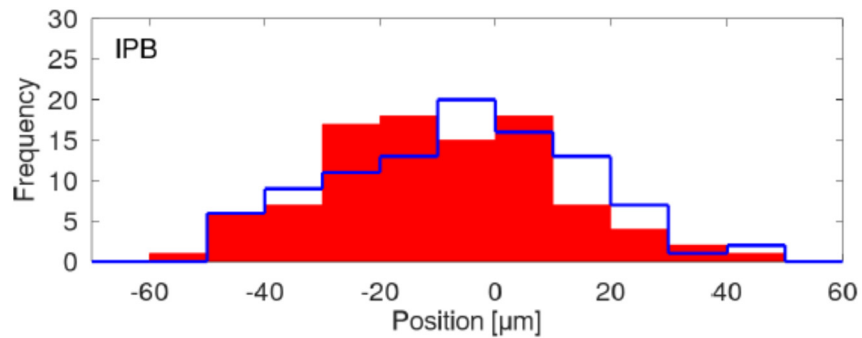
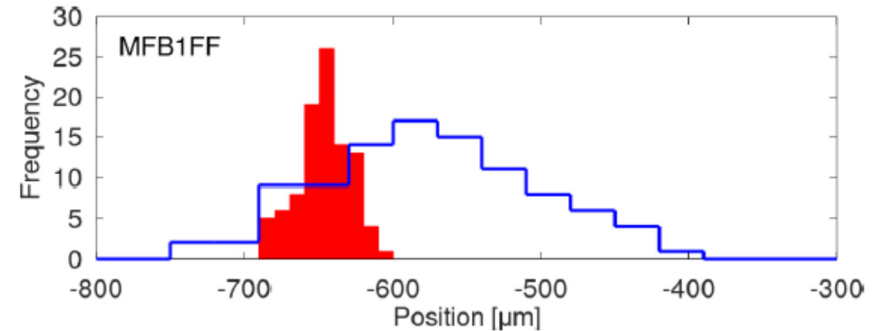
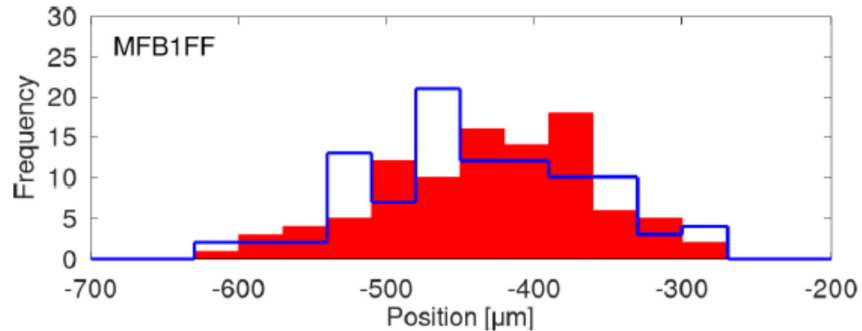

Results in terms of beam angle

Angle jitter reduced by factor ~ 4

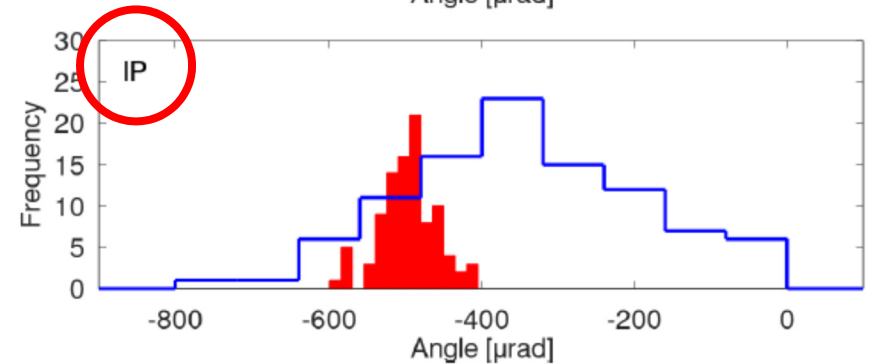
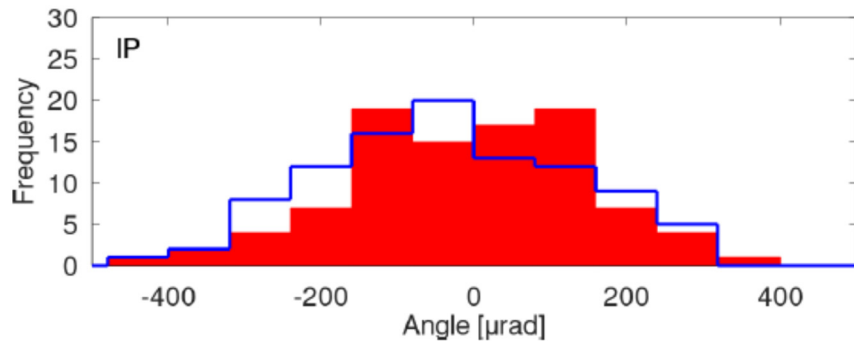
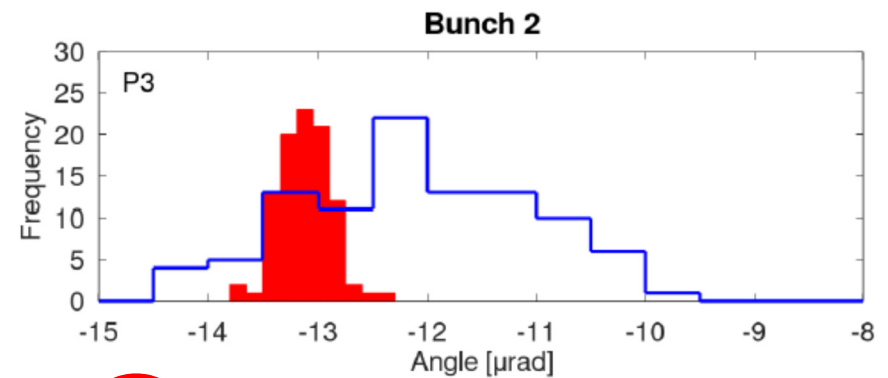
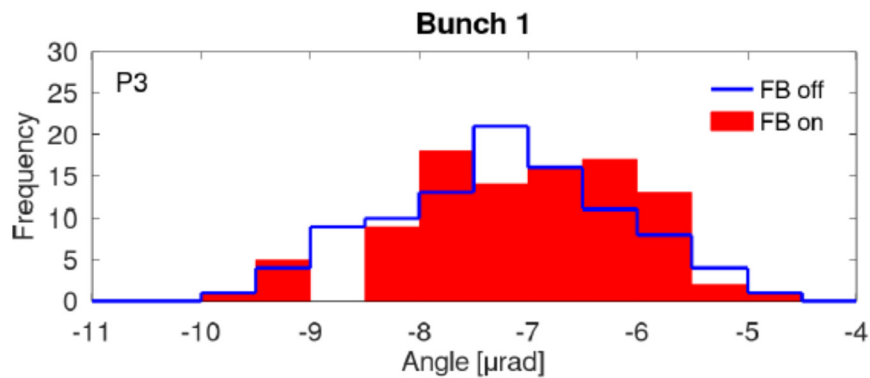

Extrapolation to IP

Track beam data from upstream region to IP using MADX model

- beam stabilised to $\sim 1\text{nm}$ at IP
- correction limited by upstream FB BPM resolution
- not possible to measure directly with 1nm resolution!

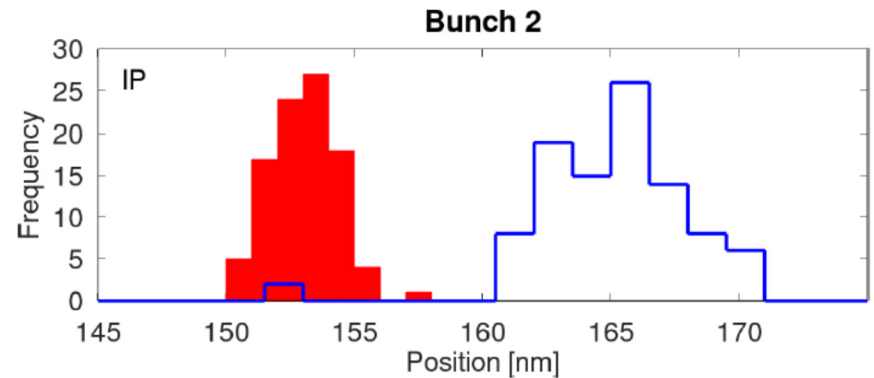
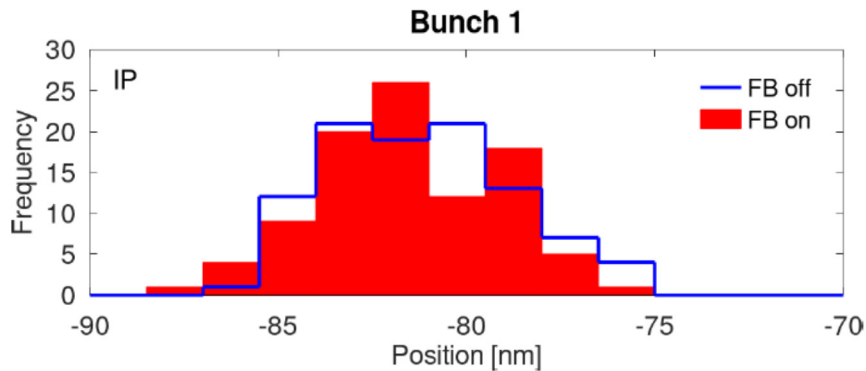
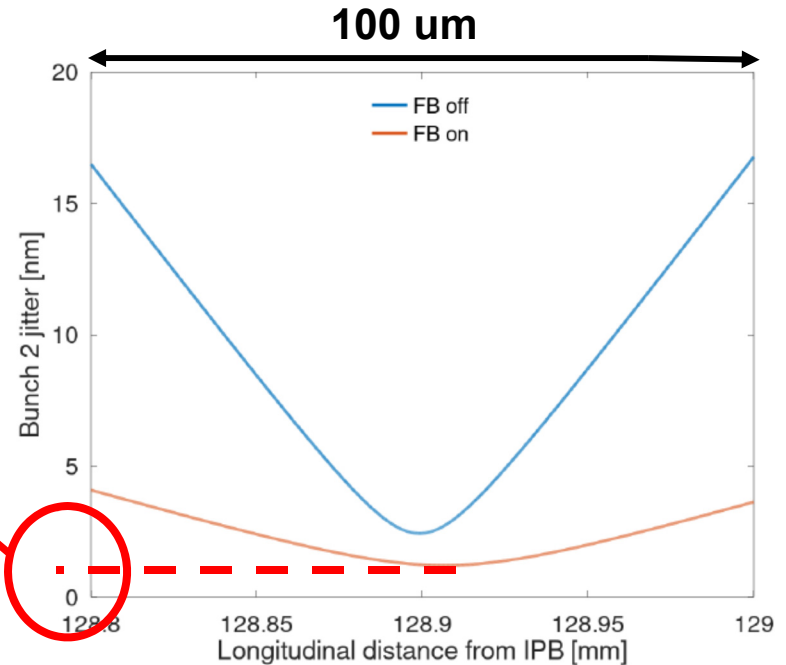

Application of upstream y-y' feedback: reduction of beam-size growth due to wakefields

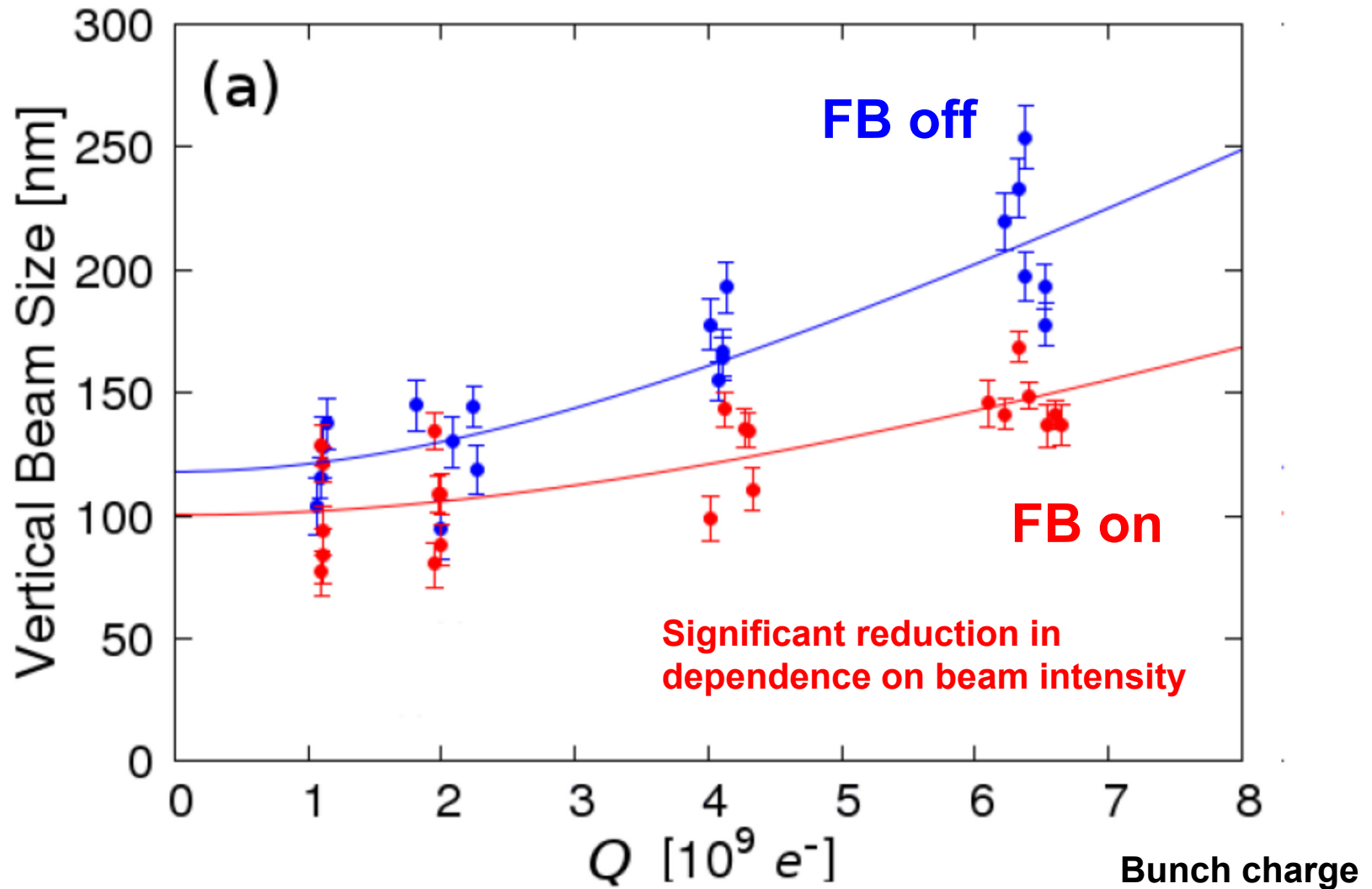

ATF2 'IP' FB system

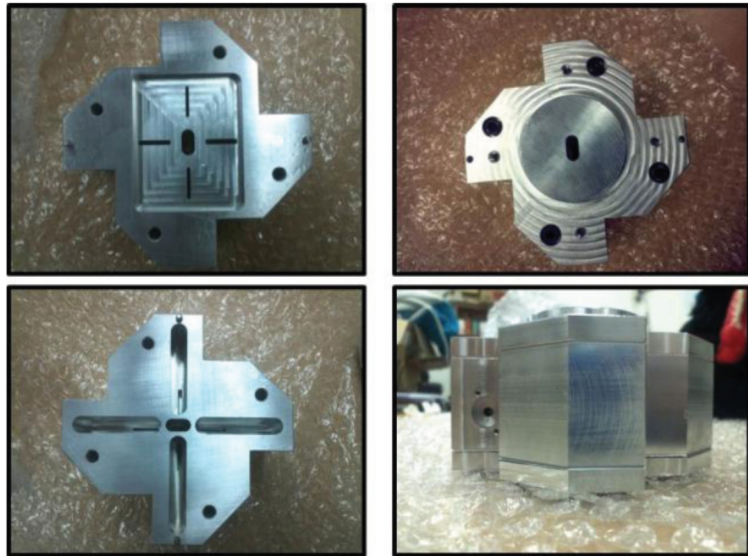
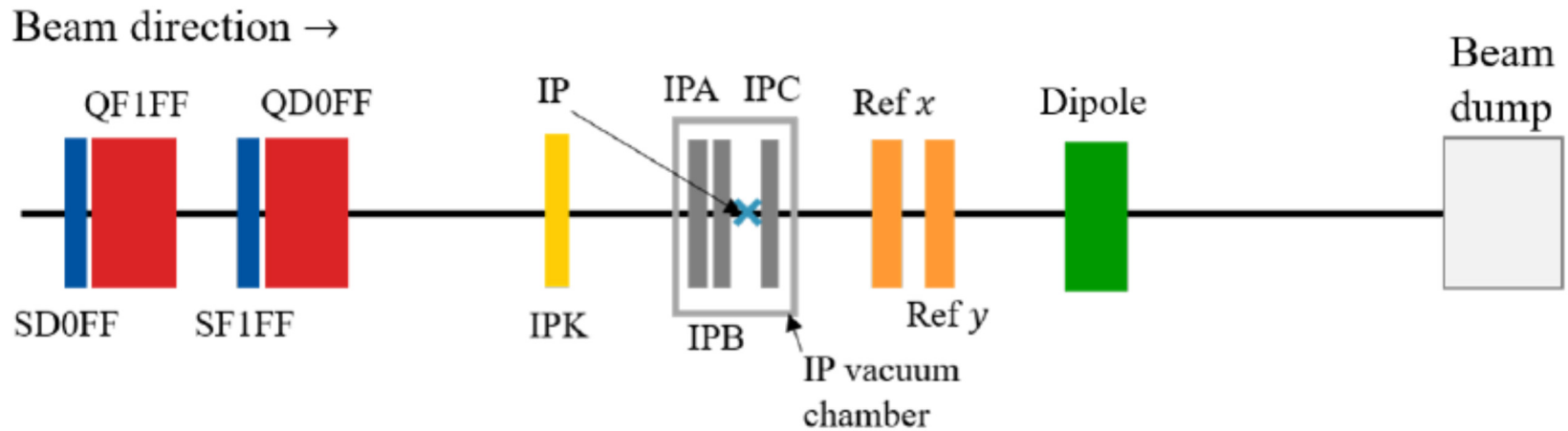

BPM cavity	Design frequency (GHz)	Measured frequency (GHz)	Decay time (ns)
Dipole IPA (<i>x</i> -port)	5.712	5.705	25
Dipole IPB (<i>x</i> -port)	5.712	5.706	25
Dipole IPC (<i>x</i> -port)	5.712	5.704	23
Dipole IPA (<i>y</i> -port)	6.426	6.428	26
Dipole IPB (<i>y</i> -port)	6.426	6.427	22
Dipole IPC (<i>y</i> -port)	6.426	6.428	21
Reference (<i>x</i> -cavity)	5.711	5.705	14
Reference (<i>y</i> -cavity)	6.415	6.428	14

ATF2 'IP' FB system

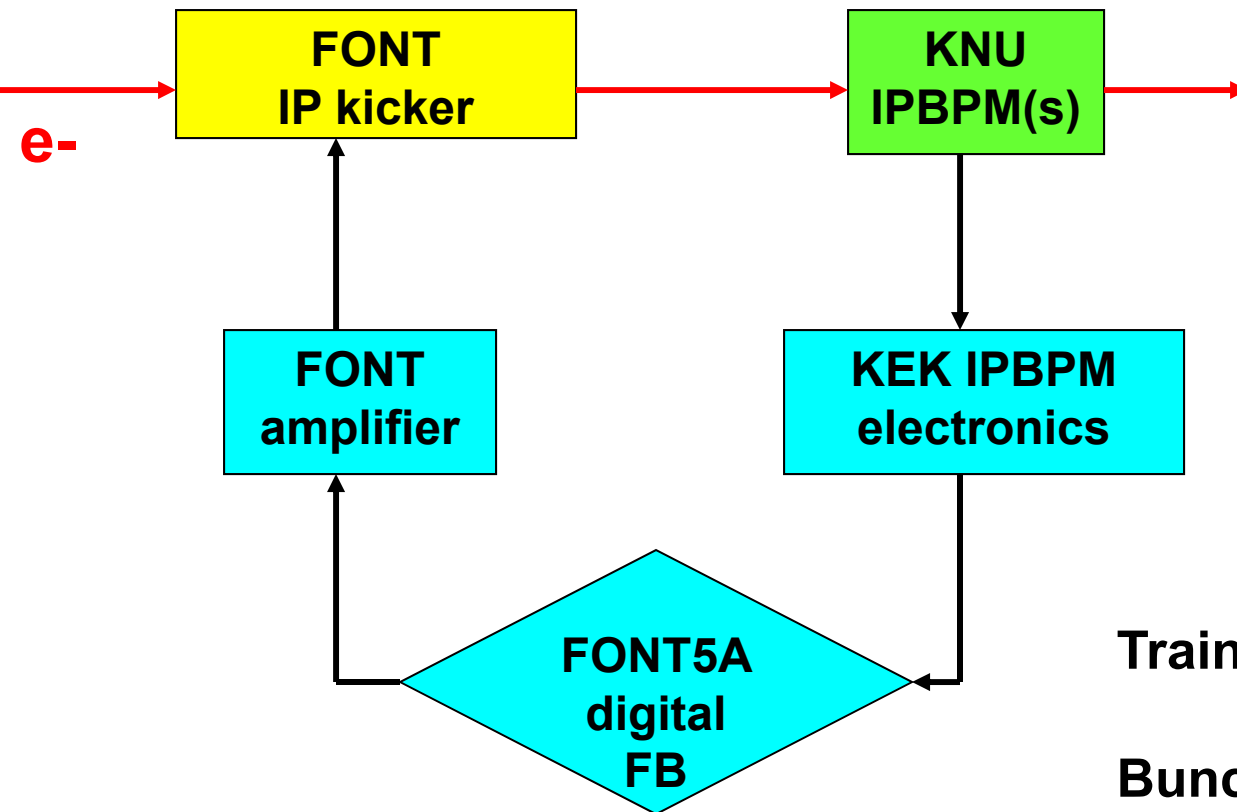

Trains of 2 bunches

Bunch separation c. 280 ns

ATF2 'IP' FB system

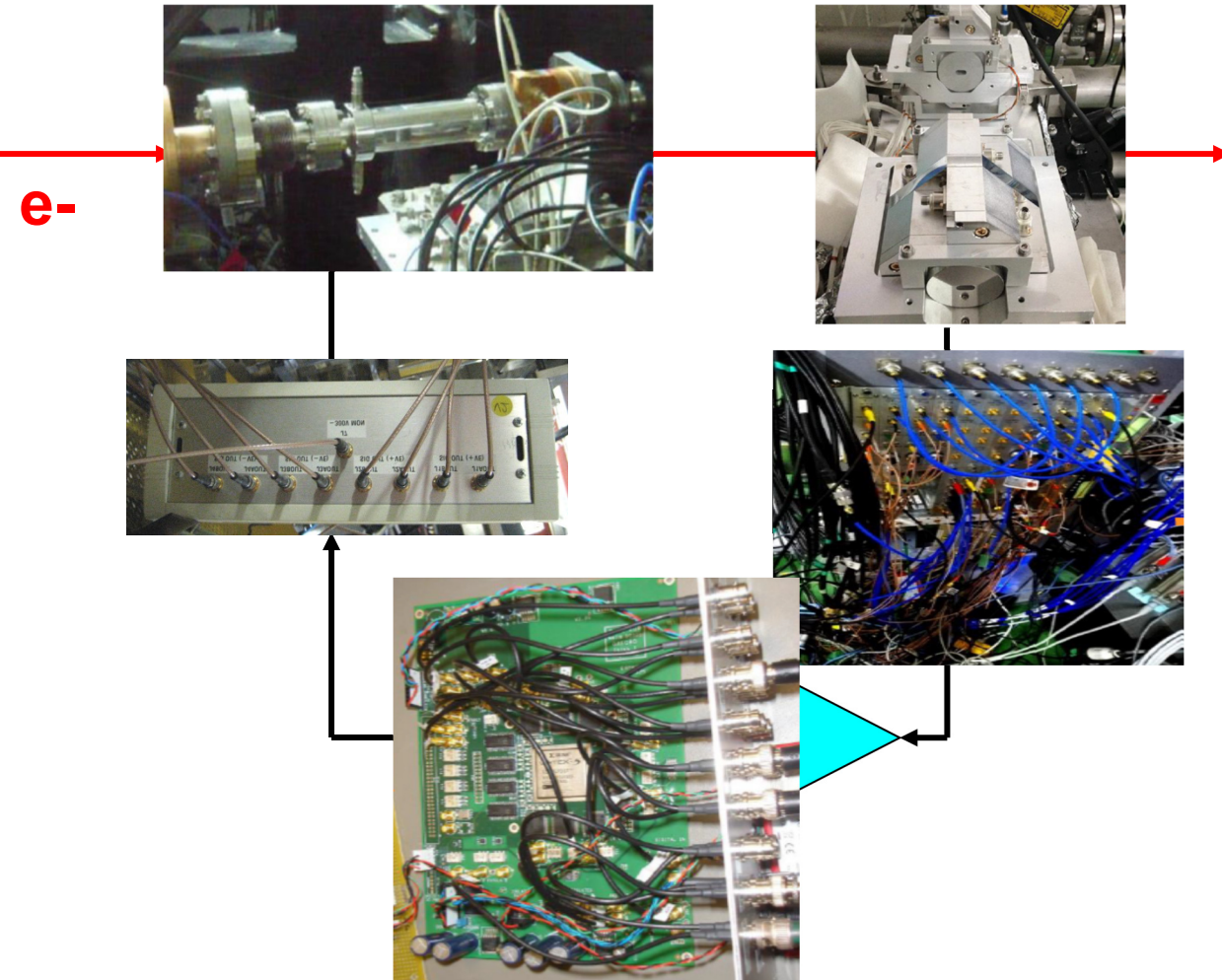

Analogue signal processor

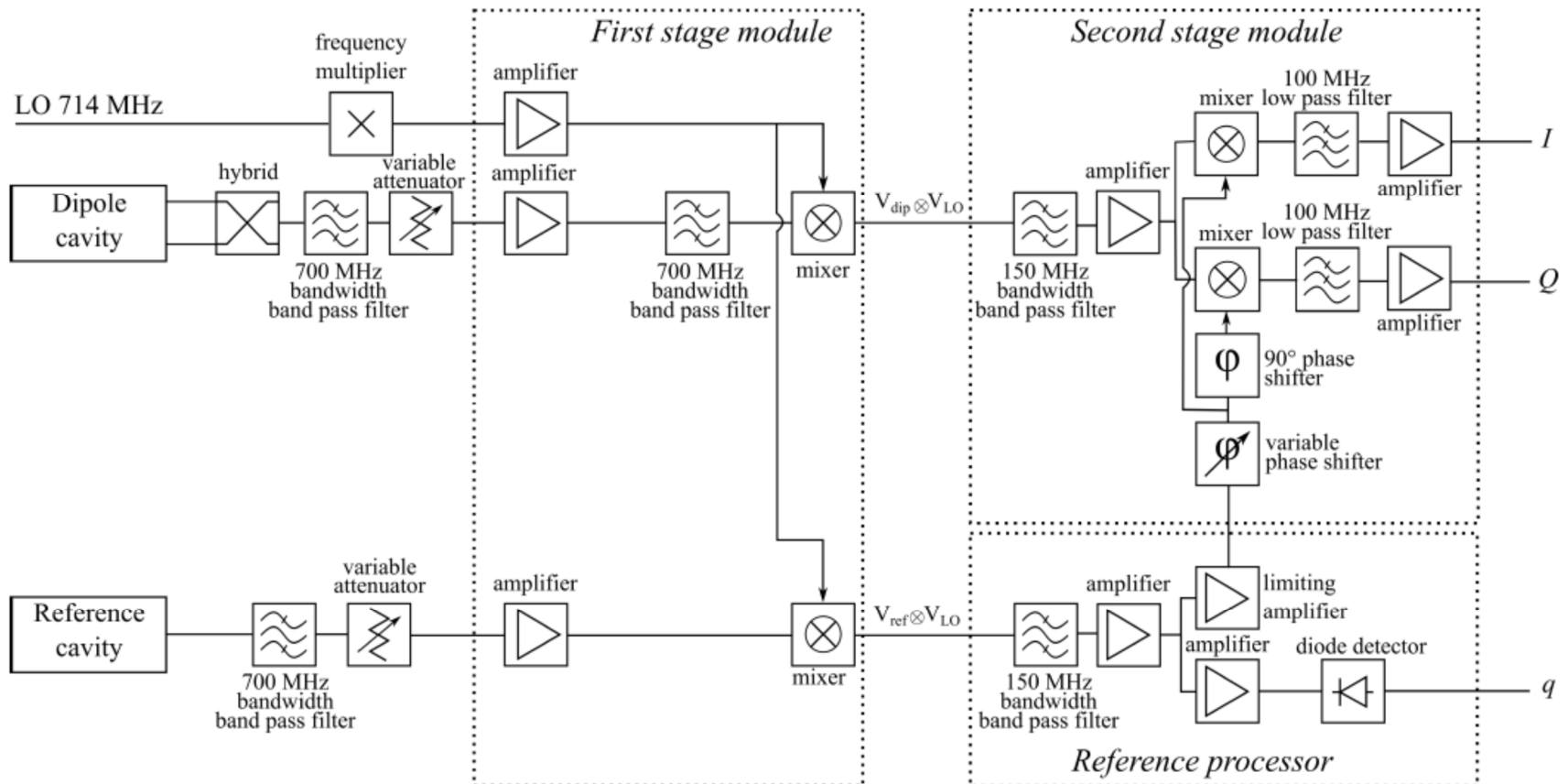

Calibration (example)

Example digitised waveforms:

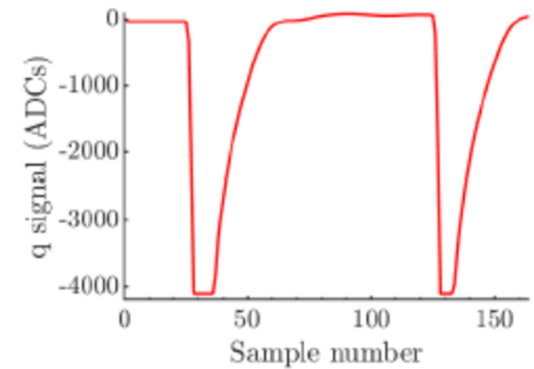
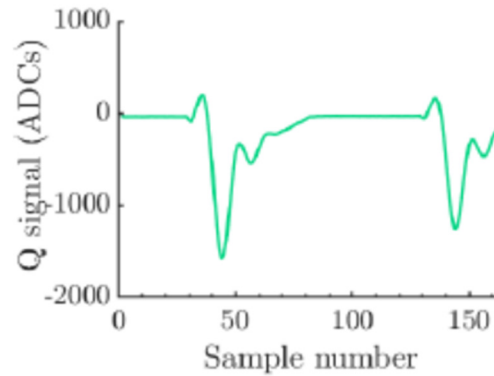
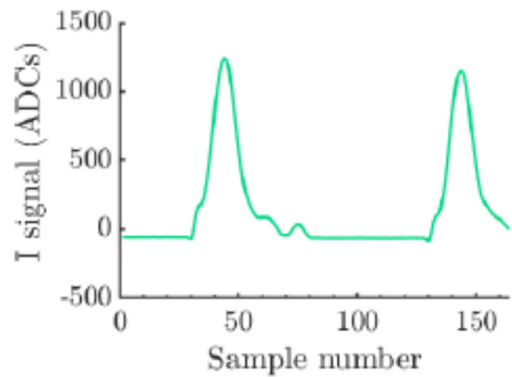

Example calibration:

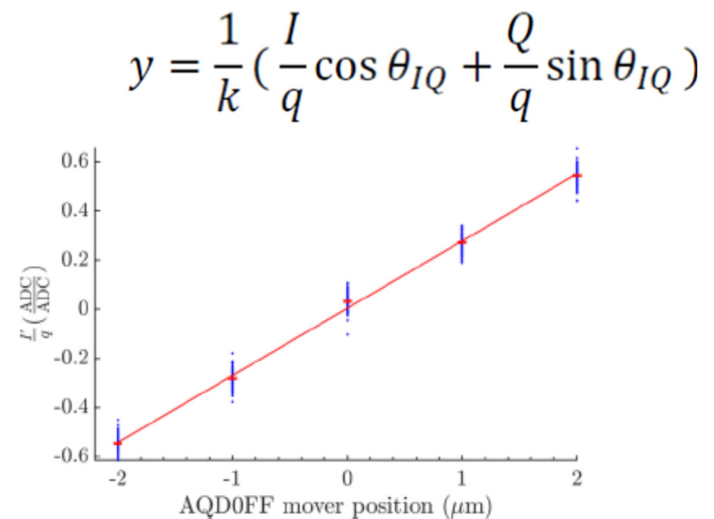
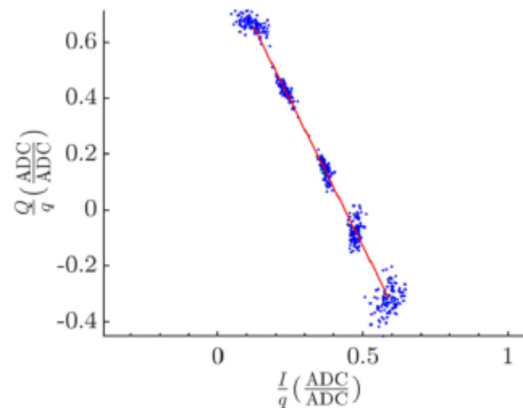
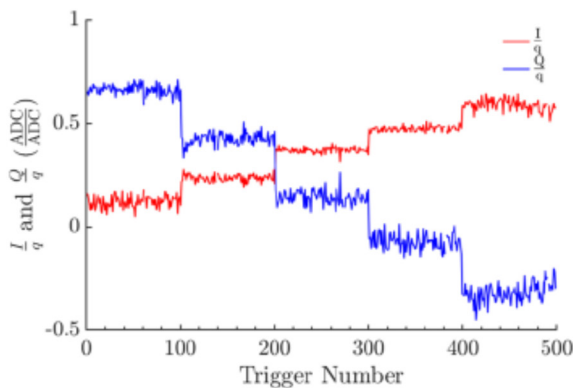

Real-time signal processing

- **Firmware runs on FPGA on digital board:**
 - Digitisation of BPM I + Q waveforms + q signal
 - Position determined from I,Q, q by applying calibration
 - Feedback signal calculated by applying gain
 - DAC output to drive kicker
 - Must meet overall system latency < bunch spacing ~ 280ns**
- **Previous version used single sample from 1 BPM as input**
- **Firmware upgraded (2018) to allow:**
 - Real-time integration of up to 15 samples in BPM waveforms
 - Input to FB loop from multiple BPMs
 - improved position resolution in real time
 - better FB stabilisation of beam
 - FB loop latency measured ~ 232 ns**

Position resolution

Ballistic beam

Use geometry of 3-BPM system to predict beam position at 3rd BPM using position measured at other two BPMs:

$$y_i^{\text{pred}} = A_{ij}y_j^{\text{meas}} + A_{ik}y_k^{\text{meas}}$$

Resolution determined from distribution of residuals:

$$\sigma = \text{std} \left\{ \frac{(y_i^{\text{meas}} - y_i^{\text{pred}})}{\sqrt{1 + A_{ij}^2 + A_{ik}^2}} \right\}_{ijk}$$

Best real-time resolution ~ 19 nm

(< 25nm routine, depends on beam)

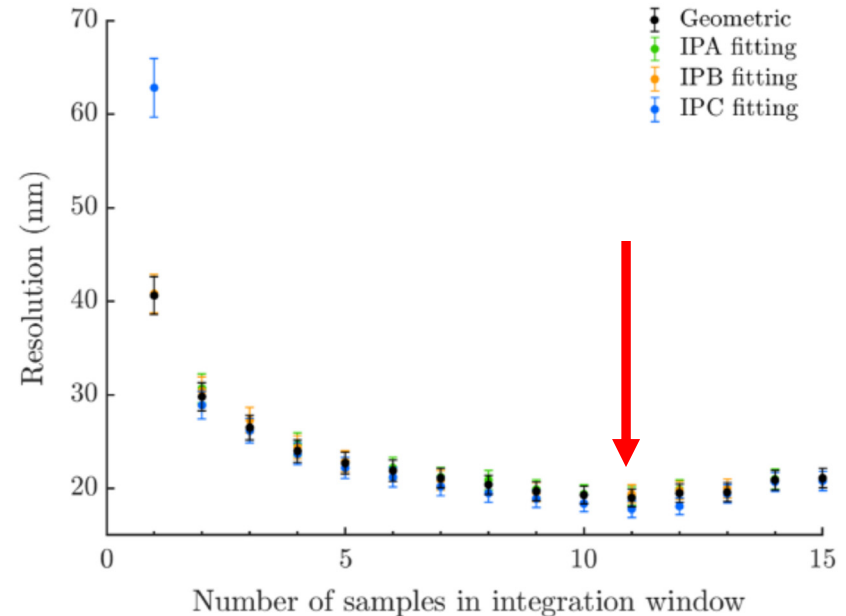
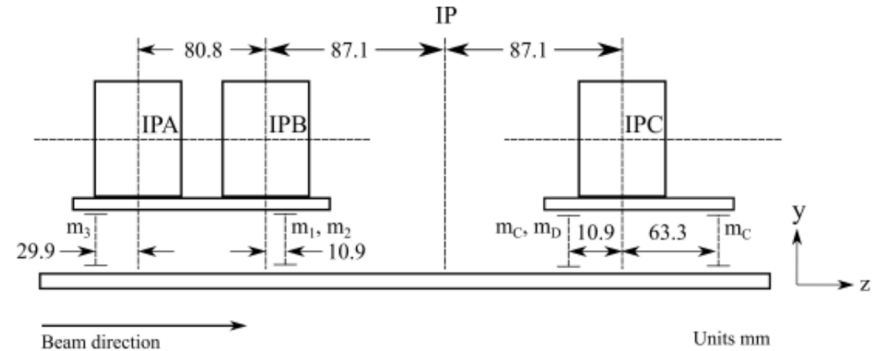

Comparison with earlier study (2008)

PHYSICAL REVIEW SPECIAL TOPICS - ACCELERATORS AND BEAMS 11, 062801 (2008)

Development of a high-resolution cavity-beam position monitor

Yoichi Inoue

Tohoku Gakuin University, Sendai, Miyagi, Japan

Hitoshi Hayano, Yosuke Honda,* Toshikazu Takatomi, Toshiaki Tauchi, and Junji Urakawa

High Energy Accelerator Research Organization (KEK), Tsukuba, Ibaraki, Japan

Sachio Komamiya, Tomoya Nakamura, and Tomoyuki Sanuki†

University of Tokyo, Hongo, Tokyo, Japan

Eun-San Kim and Seung-Hwan Shin

Kyungpook National University, Daegu, Korea

Vladimir Vogel

Deutsches Elektronen-Synchrotron, Hamburg, Germany

(Received 31 December 2007; published 16 June 2008)

We have developed a high-resolution cavity-beam position monitor (BPM) to be used at the focal point of the ATF2, which is a test beam line that is now being built to demonstrate stable orbit control at ~nanometer resolution. The design of the cavity structure was optimized for the Accelerator Test Facility (ATF) beam in various ways. For example, the cavity has a rectangular shape in order to isolate two dipole modes in orthogonal directions, and a relatively thin gap that is less sensitive to trajectory inclination. A two stage homodyne mixer with highly sensitive electronics and phase-sensitive detection was also developed. Two BPM blocks, each containing two cavity BPMs, were installed in the existing ATF beam line using a rigid support frame. After testing the basic characteristics, we measured the resolution using three BPMs. The system demonstrated 8.7 nm position resolution over a dynamic range of 5 μm .

Earlier study:

- Reported resolution ~ 9 nm
- Based on offline analysis, including a 10-parameter fit
- Calibration extrapolated from less sensitive setting
- BPMs higher-Q
- Not designed for low latency
- Not used for feed back

Our study:

- Resolution ~ 19 nm
- Real-time, directly measured
- Calibration done at most sensitive setting
- BPMs low-Q
- Low-latency system
- Used for beam feedback

ATF2 'IP' FB results

Nanobeam vertical focus placed at one BPM

Two FB modes used to correct bunch 2:

1. Only IPC used

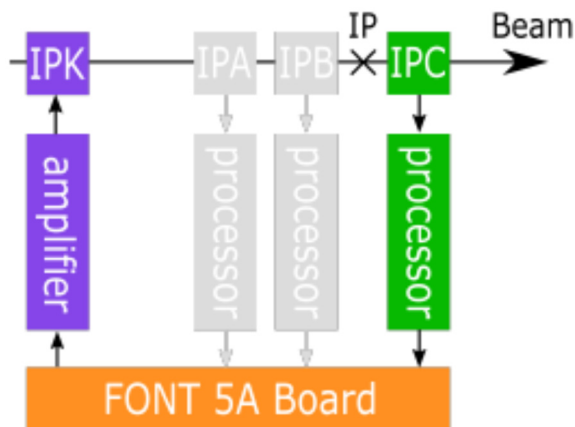

2. IPA and IPC used to correct at IPB

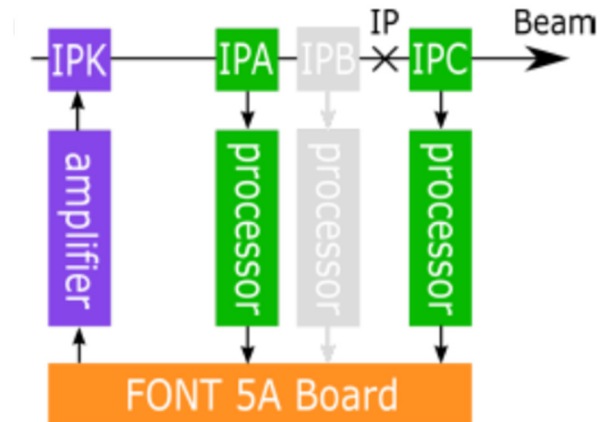

Bunch	Position jitter (nm)	
	Feedback off	Feedback on
1	109 ± 11	118 ± 8
2	119 ± 12	50 ± 4

Bunch	Position jitter (nm)	
	Feedback off	Feedback on
1	106 ± 16	106 ± 16
2	96 ± 10	41 ± 4

ATF2 'IP' FB results

Nanobeam vertical focus placed at one BPM

Two FB modes used to correct bunch 2:

1. Only IPC used

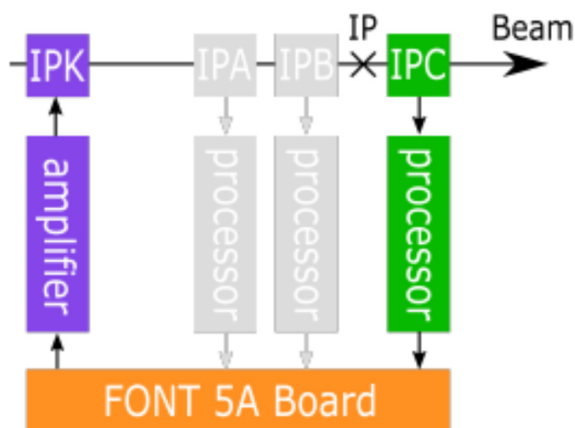

2. IPA and IPC used to correct at IPB

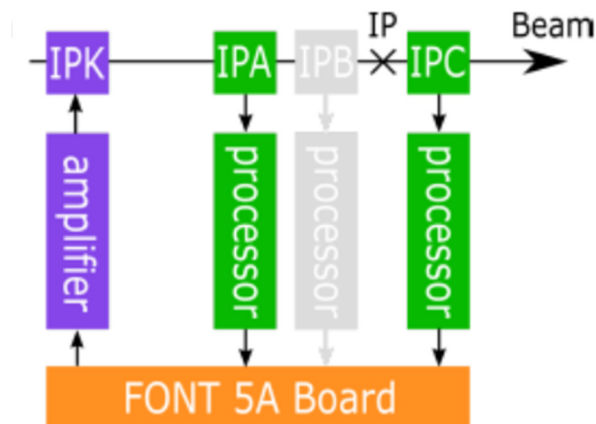

Position jitter (nm)		
Bunch	Feedback off	Feedback on
1	109 ± 11	118 ± 8
2	119 ± 12	50 ± 4

Position jitter (nm)		
Bunch	Feedback off	Feedback on
1	106 ± 16	106 ± 16
2	96 ± 10	41 ± 4

Discussion

- Beam stabilised to **~ 41 nm** in mode 2
- Agrees with prediction of 40 nm given incoming beam jitter and measured bunch-1 – bunch-2 correlation ~ 92%
- After correction, residual bunch-1 – bunch-2 correlation ~ 41%
 - **under correction, higher gain should improve**
- With 100% bunch correlation and optimal gain, performance would be resolution-limited:
 - **stabilisation to 24 nm possible in mode 2**
 - **still some margin for improvement**
- No feedback operations at ATF2 since 2019
- In future beam operations:
 - Improve beam quality (jitter, inter-bunch correlation)
 - Optimise feedback performance (gain)
 - Longer-term stability (~ hours → days)

Summary

- Developed low-latency, high-precision feedbacks incorporating both stripline and cavity BPMs
- Obtained excellent **real-time** position resolution:
 - Stripline BPM ~ 160 nm**
 - Cavity BPM ~ 19 nm**
- BPMs incorporated in digital systems for multi-bunch feedback
- ILC IP collision feedback system prototyped + tested:
 - meets ILC performance specifications**
- Upstream y-y' feedback
 - reduced wakefield blow-up of beam size by factor ~ 1.6**
 - provides capability for 1 nm-level beam stabilisation at ATF2 IP**
- ATF2 'IP' FB incorporates low-Q cavity BPMs + fast digital processor
 - nanobeam stabilised to ~ 41 nm;**
 - 24 nm is possible in principle**

Acknowledgements

We thank the KEK ATF staff for their outstanding logistical support and for providing the beam time and the necessary stable operating conditions for this research. In addition, we thank our colleagues from the ATF2 collaboration for their help and support. In particular, we thank the KNU group for fabricating the low-quality-factor BPMs, the LAL group from the Paris-Saclay University for providing the BPM mover system, and the KEK group for making available the analogue signal-processing down-mixing electronics.

We acknowledge financial support for this research from the United Kingdom Science and Technology Facilities Council via the John Adams Institute, University of Oxford, and CERN, CLIC-UK Collaboration, Contract No. KE1869/DG/CLIC. The research leading to these results has received funding from the European Commission under the Horizon 2020/Marie Skłodowska-Curie Research and Innovation Staff Exchange (RISE) project E-JADE, Grant Agreement No. 645479.

References

Stripline BPM paper

PHYSICAL REVIEW SPECIAL TOPICS - ACCELERATORS AND BEAMS **18**, 032803 (2015)

Design and performance of a high resolution, low latency stripline beam position monitor system

R. J. Apsimon,^{*} D. R. Bett,[†] N. Blaskovic Kraljevic, P. N. Burrows, G. B. Christian,[‡]
C. I. Clarke,[§] B. D. Constance, H. Dabiri Khah, M. R. Davis, C. Perry,
J. Resta López,^{||} and C. J. Swinson^{||}

*John Adams Institute for Accelerator Science at University of Oxford, Denys Wilkinson Building,
Keble Road, Oxford OX1 3RH, United Kingdom*

(Received 1 October 2014; published 19 March 2015)

A high-resolution, low-latency beam position monitor (BPM) system has been developed for use in particle accelerators and beam lines that operate with trains of particle bunches with bunch separations as low as several tens of nanoseconds, such as future linear electron-positron colliders and free-electron lasers. The system was tested with electron beams in the extraction line of the Accelerator Test Facility at the High Energy Accelerator Research Organization (KEK) in Japan. It consists of three stripline BPMs instrumented with analogue signal-processing electronics and a custom digitizer for logging the data. The design of the analogue processor units is presented in detail, along with measurements of the system performance. The processor latency is 15.6 ± 0.1 ns. A single-pass beam position resolution of 291 ± 10 nm has been achieved, using a beam with a bunch charge of approximately 1 nC.

ILC IP feedback prototype paper

PHYSICAL REVIEW ACCELERATORS AND BEAMS **21**, 122802 (2018)

Design and operation of a prototype interaction point beam collision feedback system for the International Linear Collider

R. J. Apsimon,^{*} D. R. Bett, N. Blaskovic Kraljevic,[†] R. M. Bodenstein, T. Bromwich, P. N. Burrows, G. B. Christian,[‡] B. D. Constance, M. R. Davis, C. Perry, and R. Ramjiawan

*John Adams Institute for Accelerator Science at University of Oxford,
Denys Wilkinson Building, Keble Road, Oxford OX1 3RH, United Kingdom*



(Received 13 December 2017; published 17 December 2018)

A high-resolution, intratrain position feedback system has been developed to achieve and maintain collisions at the proposed future electron-positron International Linear Collider (ILC). A prototype has been commissioned and tested with a beam in the extraction line of the Accelerator Test Facility at the High Energy Accelerator Research Organization in Japan. It consists of a stripline beam position monitor (BPM) with analogue signal-processing electronics, a custom digital board to perform the feedback calculation, and a stripline kicker driven by a high-current amplifier. The closed-loop feedback latency is 148 ns. For a three-bunch train with 154 ns bunch spacing, the feedback system has been used to stabilize the third bunch to 450 nm. The kicker response is linear, and the feedback performance is maintained, over a correction range of over $\pm 60 \mu\text{m}$. The propagation of the correction has been confirmed by using an independent stripline BPM located downstream of the feedback system. The system has been demonstrated to meet the BPM resolution, beam kick, and latency requirements for the ILC.

ATF2 y-y' feedback paper

A sub-micron resolution, bunch-by-bunch beam trajectory feedback system and its application to reducing wakefield effects in single-pass beamlines

D.R. Bett,^{a,1} P.N. Burrows,^a C. Perry,^a R. Ramjlawan,^a N. Terunuma,^b K. Kubo^b
and T. Okugi^b

^a*John Adams Institute for Accelerator Science at University of Oxford,
Denys Wilkinson Building, Keble Road, Oxford OX1 3RH, United Kingdom*

^b*High Energy Accelerator Research Organization (KEK),
1-1 Oho, Tsukuba, Japan*

E-mail: douglas.bett@physics.ox.ac.uk

ABSTRACT: A high-precision intra-bunch-train beam orbit feedback correction system has been developed and tested in the ATF2 beamline of the Accelerator Test Facility at the High Energy Accelerator Research Organization in Japan. The system uses the vertical position of the bunch measured at two beam position monitors (BPMs) to calculate a pair of kicks which are applied to the next bunch using two upstream kickers, thereby correcting both the vertical position and trajectory angle. Using trains of two electron bunches separated in time by 187.6 ns, the system was optimised so as to stabilize the beam offset at the feedback BPMs to better than 350 nm, yielding a local trajectory angle correction to within 250 nrad. The quality of the correction was verified using three downstream witness BPMs and the results were found to be in agreement with the predictions of a linear lattice model used to propagate the beam trajectory from the feedback region. This same model predicts a corrected beam jitter of c. 1 nm at the focal point of the accelerator. Measurements with a beam size monitor at this location demonstrate that reducing the trajectory jitter of the beam by a factor of 4 also reduces the increase in the measured beam size as a function of beam charge by a factor of c. 1.6.

2021 JINST 16 P01005

ATF2 nanobeam stabilisation paper

A high-resolution, low-latency, bunch-by-bunch feedback system for nano-beam stabilization

D.R. Bett, N. Blaskovic Kraljevic,* T. Bromwich, P.N. Burrows, G.B. Christian† C. Perry, and R. Ramjiawan‡

*John Adams Institute for Accelerator Science, University of Oxford,
Denys Wilkinson Building, Keble Road, Oxford OX1 3RH, United Kingdom.*

(Dated: August 26, 2021)

A low-latency, bunch-by-bunch feedback system employing high-resolution cavity Beam Position Monitors (BPMs) has been developed and tested at the Accelerator Test Facility (ATF2) at the High Energy Accelerator Research Organization (KEK) Japan. The feedback system was designed to demonstrate nanometer-level vertical stabilization at the focal point of the ATF2 and can be operated using either a single BPM to provide local beam stabilization, or by using two BPMs to stabilize the beam at an intermediate location. The feedback correction is implemented using a stripline kicker and the feedback calculations are performed on a digital board constructed around a Field Programmable Gate Array (FPGA). The feedback performance was tested with trains of two bunches, separated by 280 ns, at a charge of ~ 1 nC, where the vertical offset of the first bunch was measured and used to calculate the correction to be applied to the second bunch. The BPMs have been demonstrated to achieve an operational resolution of ~ 19 nm. With the application of single-BPM and two-BPM feedback, beam stabilization of below 50 nm and 41 nm respectively has been achieved with a latency of 232 ns.

CLIC IP FB simulation paper



PUBLISHED BY IOP PUBLISHING FOR SISSA

RECEIVED: July 29, 2010

ACCEPTED: August 24, 2010

PUBLISHED: September 21, 2010

Luminosity performance studies of the compact linear collider with intra-train feedback system at the interaction point

J. Resta-López,¹ P.N. Burrows and G. Christian

*John Adams Institute for Accelerator Science, Oxford University,
Oxford, OX1 3RH, U.K.*

E-mail: j.restalopez@physics.ox.ac.uk

ABSTRACT: To achieve the design luminosity at future linear colliders, control of beam stability at the sub-nanometre level at the interaction point will be necessary. Any source of beam motion which results in relative vertical offsets of the two beams at the interaction point may significantly reduce the luminosity from the nominal value. Beam-based intra-train feedback systems located in the interaction region are foreseen to correct the relative beam-beam offset and thus to steer the two beams into collision. These feedback systems must be capable of acting within the bunch train. In addition, these feedback systems might considerably help to relax the tight stability tolerances required for the final doublet magnets. For the Compact Linear Collider (CLIC), the extremely short nominal bunch spacing (0.5 ns) and very short nominal pulse duration (156 ns) make the intra-train feedback implementation technically very challenging. In this paper the conceptual design of an intra-train feedback system for the CLIC interaction point is described. Results of luminosity performance simulations are presented and discussed for different scenarios of ground motion. We also show how the intra-train feedback system can help to relax the very tight tolerances of the vertical vibration on the CLIC final doublet quadrupoles.

2010 JINST 5 P09007