

# COMPARISON OF TWO LONG TERM DRIFT STABILIZATION SCHEMES FOR BPM SYSTEMS.



Frank Schmidt-Foehre, Gero Kube, Kay Wittenburg  
(Deutsches Elektronen-Synchrotron DESY, Germany)

## Introduction

Some 3rd generation synchrotron radiation sources like PETRA III at DESY are planned to be upgraded into 4th generation low-emittance synchrotron light sources over the next years.

These new machines require much smaller beam sizes at the insertion device source points for generation of high brilliant photon beams. In addition, improved long-term drift performance of BPM position measurement will be needed to cope with the corresponding level of accuracy for the required control orbit stability.

A large amount of well-known high-resolution button BPM systems will be used as workhorses around such a ring for appropriate beam position measurement and stability control (orbit-feedbacks).

PETRA IV will utilize considerably long frontend cables up to 100m for the BPM system due to:

- avoiding radiation sensitive electronics in the tunnel
- the large accelerator circumference (2.3 km)
- space limitations inside the tunnel.



The cables connect the BPMs in the tunnel with their readout electronics outside the tunnel. Certain parts of the cable will be conducted outside the tunnel under harsh, unstable environmental conditions.

Compensation schemes will be used, to control the environmental impact on BPM cable parameters, resulting in long-term drifts of the measured beam position, to a sufficiently low level. These long cables, carrying sensitive analog button RF-signals, are exposed to long-term deviation of critical signal propagation properties like the relative dielectric permittivity ( $\epsilon_r$ ) through drifts of environmental parameters like temperature, humidity and mechanical stability.

The compensated signal path should incorporate as much of the BPM cable as possible to cope for parameter deviations along this cable segment. In consequence, this needs an electronic device for handling of the compensation scheme, located at the beginning (close to the BPM) and another one at the end of the compensated signal path (e.g. included in the BPM frontend).

Two main compensation concepts and their technical implementations are discussed here, together with their common similarities and differences, their individual pro's and con's in comparison to the needs and preferences for use in the future PETRA VI synchrotron light source.

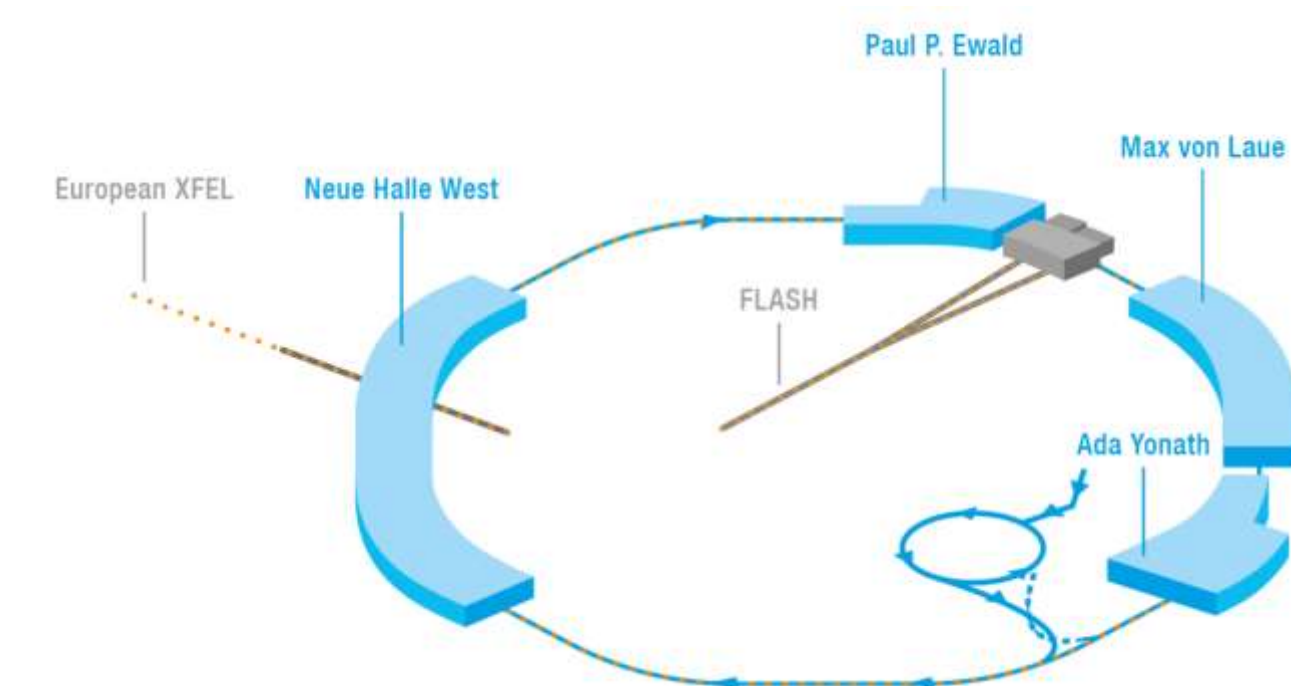

PETRA IV – storage ring with pre-accelerators and experimental halls

## Compensation schemes

The main goal of a fast auto-compensation scheme like Pilot-Tone (PT) or Crossbar-Switching (CS) is, to reduce temporal drifts of hardware components, circuits and cabling in the whole analog BPM button RF-signal chain related to various effects, like e.g. drifts of environmental parameters, mechanical forces and aging.

Four years ago, a new BPM frontend compensation scheme was introduced for the ELETTRA storage ring at the Sincrotrone Trieste in Italy, which has been tested and is now in use at different accelerators. Meanwhile, this system is manufactured in collaboration with the Instrumentation Technologies d. d. company at Solkan, Slovenia. It is mainly used in combination with the Libera Spark readout electronics of the same company.

A pre-series PT frontend has been tested in a test setup in combination with a non-switching Libera Spark readout electronics at the PETRA III ring at DESY in 2019 for performance comparison against other existing BPM readout electronics (Libera Brilliance+ and Libera Brilliance).

Another compensation scheme, developed by the Instrumentation Technologies d. d. company at Solkan, Slovenia 20 years ago for the SLS at PSI, Switzerland uses a continuously and synchronously-permuting crossbar-switching/de-switching scheme for all of the 4 BPM button RF input channels inside the readout electronics device. It enables real-time compensation of amplitude and phase at each BPM button signal channel in reference to the average of all 4 channels.

This contemporary crossbar-switching scheme is intended to work along the internal analog RF-frontend input signal paths. DESY has many years of operational experience with the Libera Brilliance BPM readout electronics used at PETRA III, which uses this device-internal crossbar-switching compensation scheme.

## Pilot-Tone frontend box

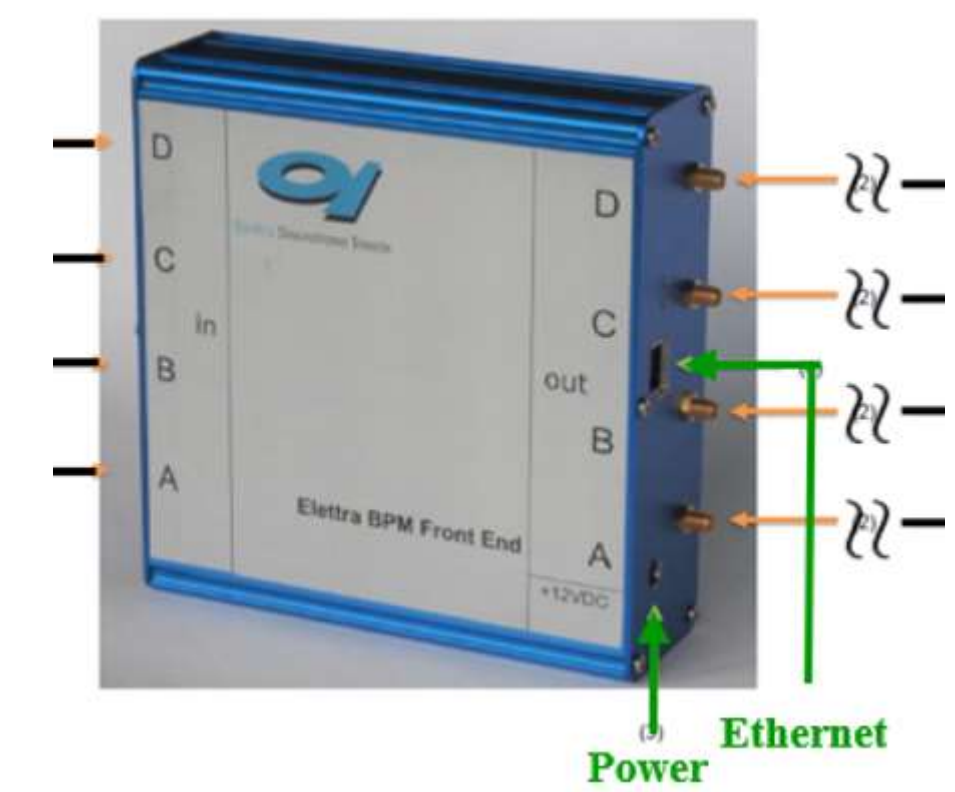

The ELETTRA BPM Pilot-Tone frontend box (\*)

A Pilot-Tone (PT) compensation system uses an artificial sinusoidal cw pilot tone, which is added into each BPM button signal chain inside an electronic box located at the foremost coupling opportunity just behind the button output connector (an appropriate signal combiner/splitter combination is used for equalization of button signals for test).

## Pilot-Tone frontend injection

The pilot-tone (PT) signal is added to the button signal spectrum at the input of the transmission channel and extracted at the other end of the channel for the recovery of the original transmitted BPM signals and for comparison against the originally frontend-injected tone-signal for signal-transmission control.

As the PT has to be transmitted using the same channel settings as used for the original button signal, the separation process produces an impact on the spectrum of the useful button signals by the non-ideal side-lobes of the required filter.

The PT scheme is able to provide absolute measurements of signal attenuation at the used PT frequency, as it uses a single tone for signal propagation measurement and compensation. This measurement relies on a perfectly adjusted and stable pilot-tone signal (amplitude, frequency).

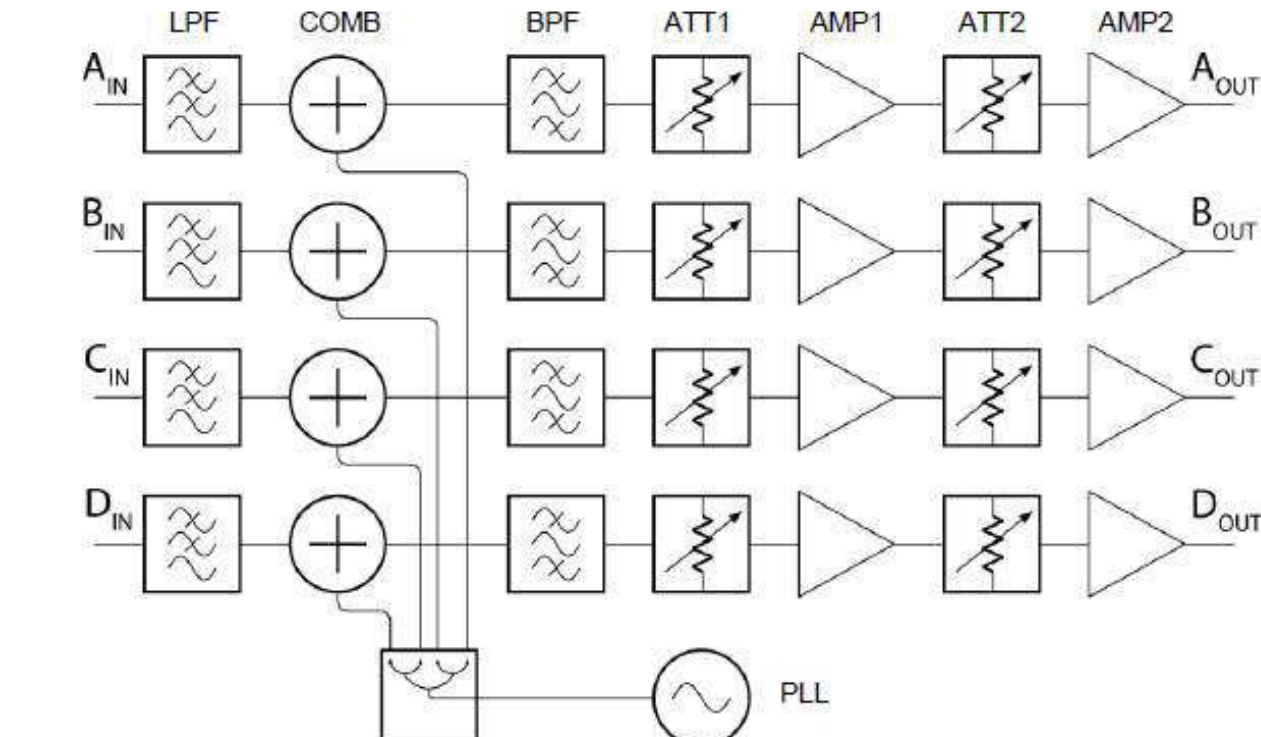

ELETTRA BPM Pilot-Tone (PT) frontend (\*)

(\*) G. Brajnik, S. Carrato, S. Bassanese, G. Cautero and R. De Monte, "Pilot tone as a key to improving the spatial resolution of eBPMs", in Proc. AIP Conf., vol. 1741, 2016, Art. no. 020013.

## Pilot-Tone test setup

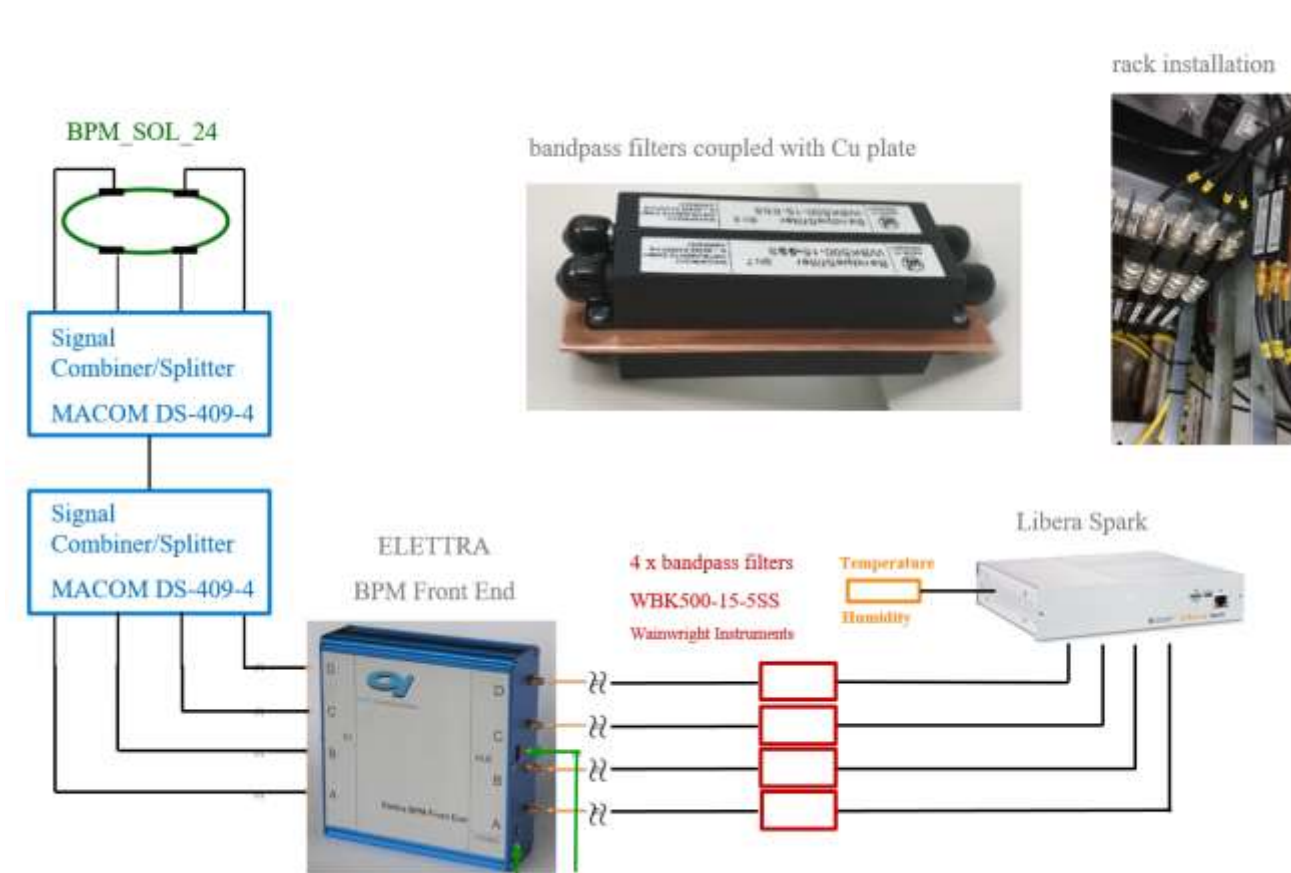

Button BPM setup with PT frontend and adapted Libera Spark (\*\*) readout electronics

The figure above shows a typical Pilot-Tone (PT) setup as used for the Petra III test measurements, that were carried out using different beam modes in 2019.

(\*\*) Refer to instrument descriptions and manuals by Instrumentation Technologies d. d. company, Solkan, Slovenia for details.

## Similarities

Both compensation schemes (PT and ECS) correct for signal drifts, resulting in an increased drift performance of the compensated BPM channel.

Both schemes can be set up statically via the control-system. These settings remain stable as long as the electrical boundary conditions remain.

As a common drawback, both auto-compensation schemes disturb the turn-by-turn (TbT) BPM measurements by their individually generated spectral artefacts. This has to be handled accordingly during measurement at beam operation. On the other hand, this will not be problematic within regular user operation, as TbT data is typically acquired on demand for 1st turn, commissioning and machine study measurements and might even serve as a mechanism for proof of function for the individual compensation scheme during normal operation. In addition, any data stream used for feedback applications shall be sufficiently free of residual compensation artefacts.

To cope with this task, both variants similarly add an electronic module to the signal chain in close vicinity of the BPM chamber and act upon the BPM button-signals at the earliest possible stage in the signal-chain behind the BPM, to minimize the length of uncompensated paths in the button signal chains. Nevertheless, both solutions leave short uncompensated signal-paths between the BPM buttons and this first electronic-boxes, that have to be drift-stabilized by other means (e.g. rigid cables, temperature-stabilized tunnel environment). Note that additional electronics near the beam need radiation hard designs and appropriate shielding. Radiation measurements under operational conditions shall clarify existing radiation hardness and enable estimations for ideal location and sufficient shielding of the frontend devices inside the tunnel.

Both schemes need an additional cable connection to carry support signals from the readout- to the additional frontend-electronics near the BPM inside the tunnel. These signals and cables increase the BPM channel cost and risk of errors due to EMI or electro-mechanical malfunction.

In case of irreversible failure of the compensation frontend-electronics, the remaining part of the compensation in the readout-electronic backend has to be deactivated accordingly, resulting in an intermediate drift of the BPM measurement until repair.

## Spectrum example (PT)

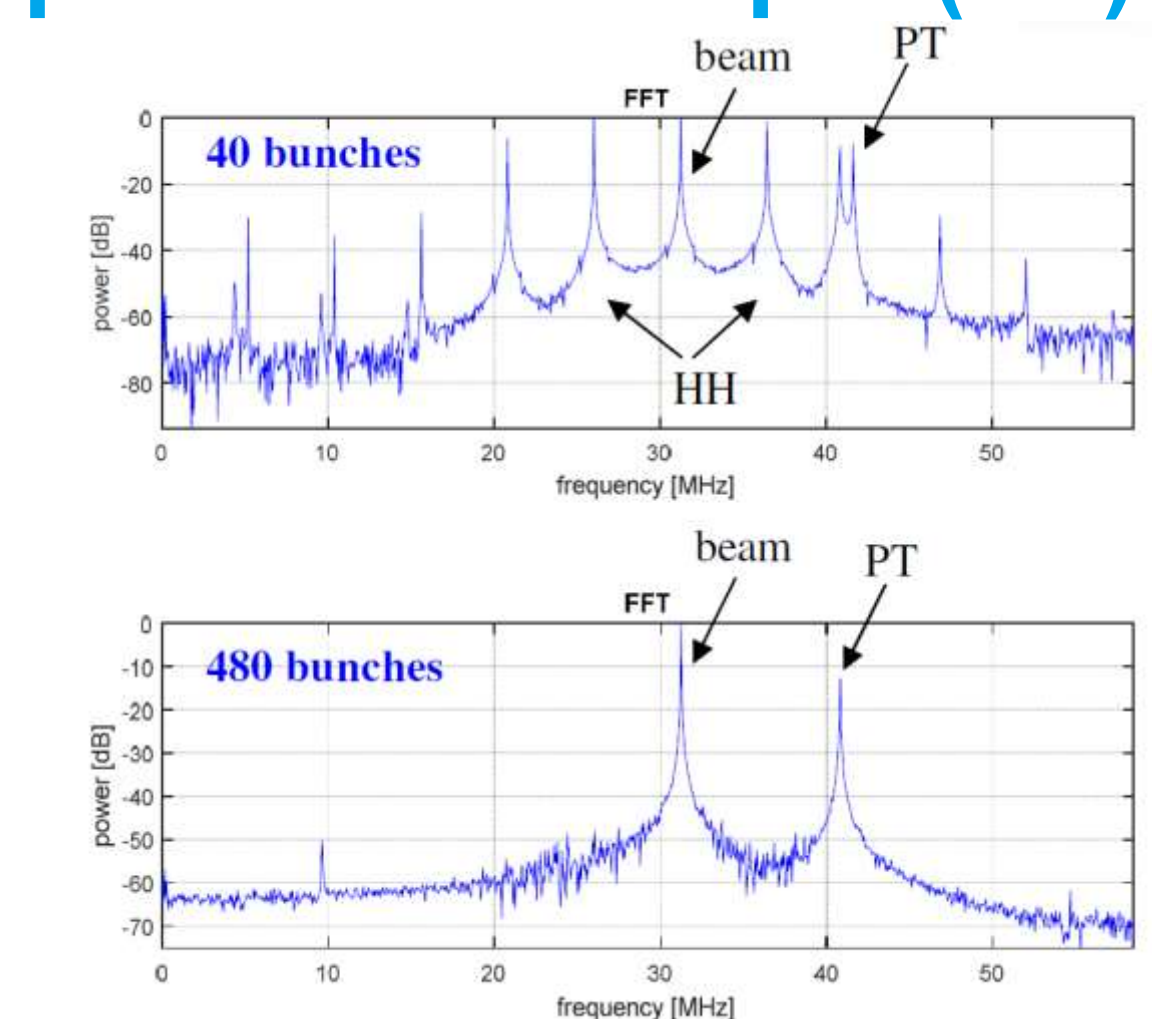

Typical amplitude spectra of a PT system used for PETRA III test measurements at 40 bunch/100mA and 480 bunches/120mA beam modes (HH: higher harmonics).

The PT scheme compensates for parameter drifts in the BPM button-signal measurement channel by measuring, comparing and compensating deviations of an artificial, discrete sinusoidal cw signal, that is located in direct spectral vicinity to the carrier frequency of the beam (example at the PETRA III test installation: ~1-5MHz from beam center frequency at 30MHz bandwidth). The figure above shows a typical amplitude spectrum of a PT setup as used for Petra III test measurements, carried out using different beam modes in 2019.

## Differences

Main differences in the compensation schemes can be found in their functional concepts, the implementations and its operational consequences.

The PT scheme compensates for parameter drifts in the BPM button-signal measurement channel by measuring, comparing and compensating deviations of an artificial, discrete sinusoidal cw signal, that is located in direct spectral vicinity to the carrier frequency of the beam.

As PT uses a single tone for signal propagation measurement and compensation, it is able to provide absolute measurements of signal attenuation at the used PT frequency. This measurement relies on a perfectly adjusted and stable pilot-tone signal (amplitude, frequency).

To the contrary, the ECS switches between the 4 BPM button signals, thus producing spurious lines in the original spectrum. These discrete switching frequencies are configured and adjusted such to reside far away from critical frequencies inside the BPM button signal spectrum and can be filtered out efficiently through steep log-in notch filters, synchronized to the accelerators machine frequency. Residual spike-like switching artefacts are eliminated further by a synchronized, single data substitution algorithm for generation of low residue, broadband TbT data. No more artificial spectral components are added to the original BPM button spectrum within the fully synchro-nous ECS scheme by design.

An ideal compensation scheme should take the whole button-signal spectrum into account for compensation bandwidth. While the PT scheme relies only on the deviation representativity of a singular, un-synchronized cw signal, the ECS scheme uses the full-spectrum BPM button-signal as a control-variable for the auto-compensation control-loop.

The PT concept needs a couple of additional analog and digital hardware components and circuits to add and extract the required pilot-tone signal into the spectrum and attenuation framework of the original BPM button signals.

## External Crossbar Switching (ECS)

An adapted external switching scheme was suggested by DESY and others, which incorporates the BPM RF-cables in front of the readout-electronics inputs.

Compared to contemporary crossbar-switching, this new scheme shifts the electrical analog crossbar-switching part as far as possible towards the frontend of the signal chain close to the BPM chamber.

A first prototype of such ECS scheme was recently developed in a collaboration between DESY and Instrumentation Technologies d. d. and tested in a setup at PETRA III as shown in the figure below. First measurements with this prototype are presented in the MOPP30 paper at this conference.

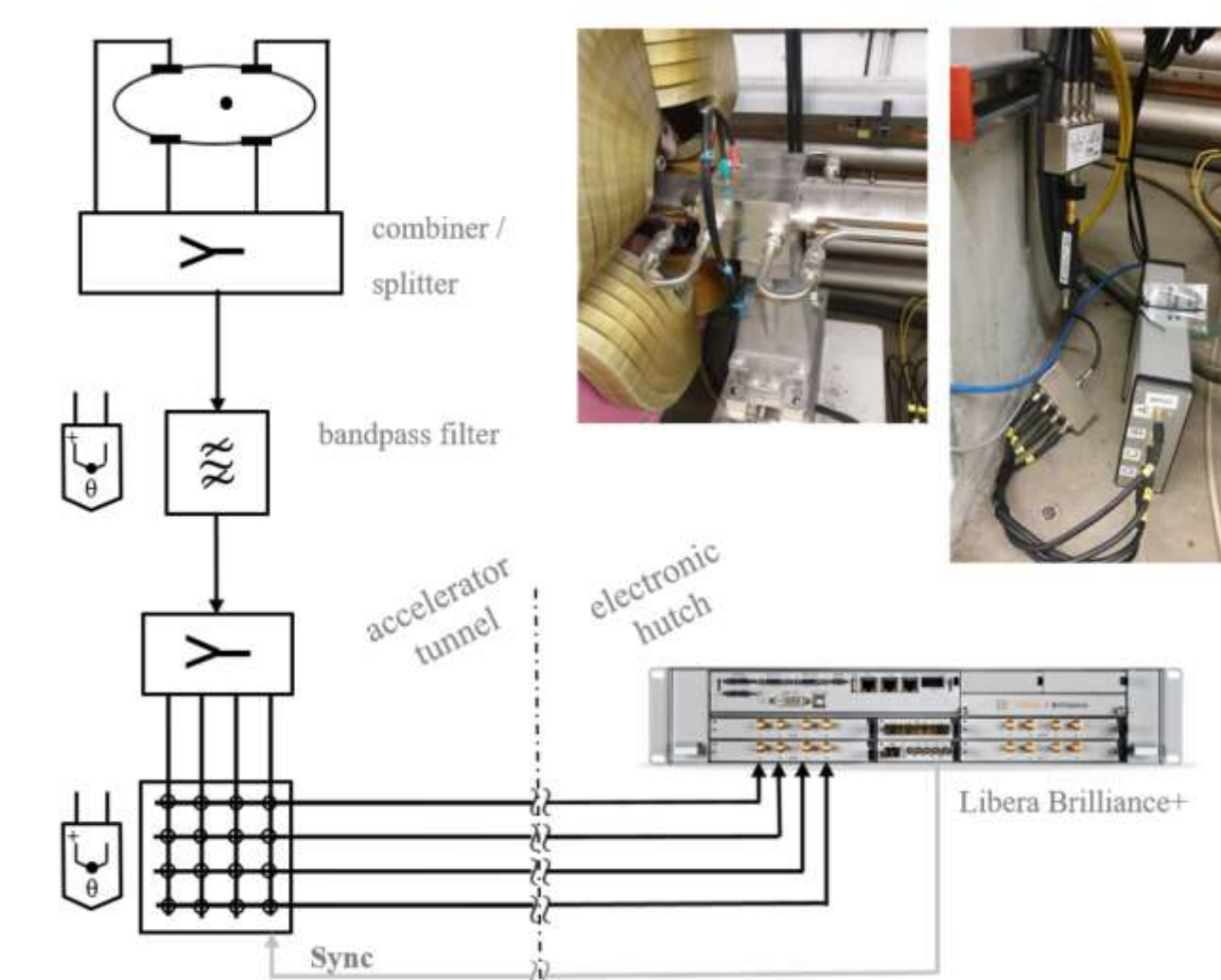

Button BPM test setup with external crossbar-switching (ECS) frontend and adapted Libera Brilliance+ (\*\*) readout electronics.

## Discussion

As the point of compensation impact is shifted maximally towards the BPM frontend inside the tunnel with both, the ECS and the PT compensation schemes, both of them will stabilize the drifts in the major part of the transmission channel.

PT compensates for drifts of calculated position signals, that are derived from all underlying disturbed raw button signal channels at once during the readout process. This scheme relies on the fact, that the drift of the dielectric cable permittivity ( $\epsilon_r$ ) is constant over the frequency region-of-interest and similar to the value at PT signal frequency. Due to the concept of PT scheme, the artificial pilot-tone signal disturbs the signal integrity of the original BPM button-signals and may produce spurious spectral lines.

If the individual pilot-tone reference signal of a PT frontend is adjusted as a standard, the Pilot-Tone scheme offers auto-calibration against that standard reference signal, as well as auto-drift compensation.

As the PT reference signal-level dynamics are critical for overall measurement performance, they might need dynamic adaption and further optimization to achieve full system performance over the full dynamic measurement range.

ECS compensates the drifts in the raw electrical source signals from the individual BPM buttons and levels the impact from the main influencing environmental parameters to stabilize the derived position value. At ECS, the resulting compensated BPM button signal-transmission channels are free of drifts above a reasonably low level, determined by the granularity of the compensated drift parameters (amplitude, phase) as implemented in the respective digital acquisition system.

The ECS utilizes the full usable bandwidth of the original button signals, thus providing ideal full-bandwidth loop control without neglecting any probably critical spectral parts of the compensated transmission channels.

## Conclusion and outlook

An External Crossbar Switching (ECS) system offers simple and well-known building blocks. This compensation scheme follows the guideline, to compensate systematic errors as imposed by signal transmission drifts at their source of impact.

As it does not add significant artificial parts to the useful button-signals, as well as utilizing the full usable bandwidth of the original BPM button signals for compensation, it seems to be conceptually well suited for use in the planned PETRA IV project.

Radiation tolerance of the ECS and Pilot-Tone (PT) frontend boxes and compensable dynamic ranges due to drifts of main environmental parameters exposed to BPM cables shall be tested for implementation.

As both Pilot-Tone- (PT) and Extended-Crossbar-Switching (ECS) compensation schemes use electronics inside the tunnel, regular self-tests of the frontend electronics should be considered for device degradation and failure recognition in due time, to support preventive maintenance.