



Elettra Sincrotrone Trieste

Integration of a pilot-tone based BPM system within the global orbit feedback environment of Elettra

G. Brajnik, S. Bassanese, G. Cautero, S. Cleva, R. De Monte

Elettra – Sincrotrone Trieste

- Introduction
- Pilot tone compensation
- eBPM prototype at Elettra
- Characterization and Performances
- Integration and results with beam

- Goal of the project is the development of a innovative BPM system for electron storage rings (Elettra, Elettra 2.0) based on pilot tone compensation
- Specifications:
 - Sub-micron resolution @ 10 kHz
 - Long-term stability better than 2 μm in 24 hours
 - Compensation of thermal drifts, channel variations, cables response
- Modular system:
 - Analog RF front end
 - FPGA-based digitiser
 - Computation unit for control systems (Tango, Epics)

Pilot tone: proposed implementation by Elettra

- A fixed sinusoidal tone is added to the original signal coming from the beam;
- The 4 channels use the same tone as reference;
- The pilot tone frequency has to fall near the carrier one without interfering with the latter;

Typical spectrum of
a eBPM button plus
the pilot tone

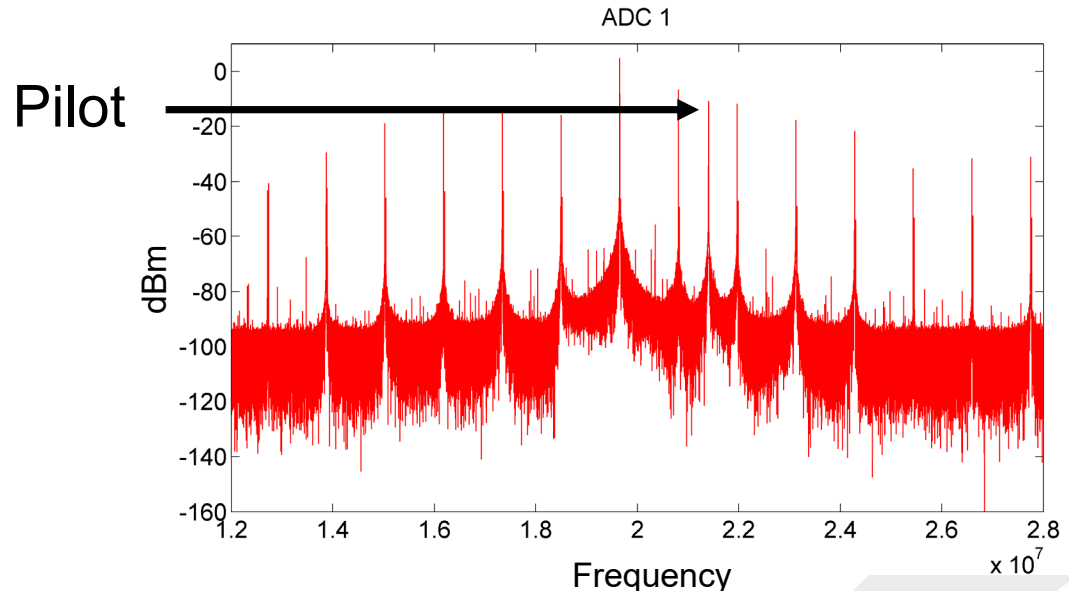

Compensation technique

Hypothesis: every channel variation affects in the same way both the carrier and the pilot

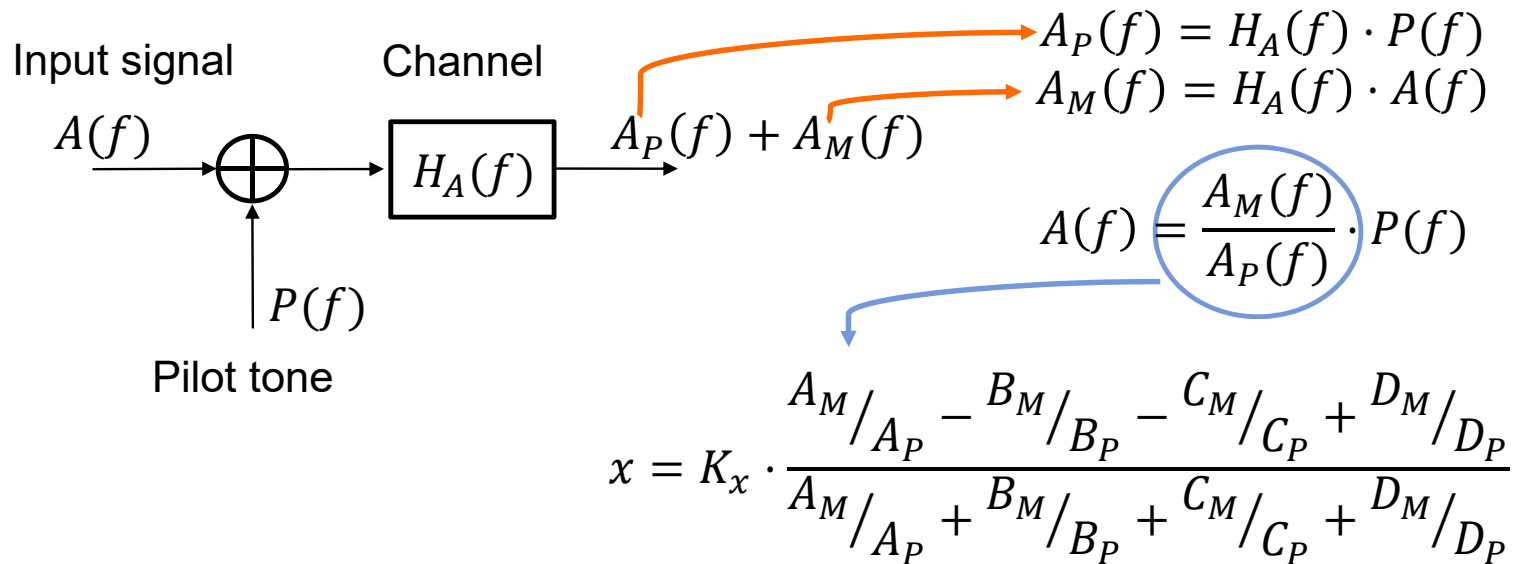

Compensated position in classical Difference-over-Sum (DoS) equation

- Compensation of cables
 - Possible when the tone is injected near to the pick-ups
- No need for thermoregulation
 - Thermal drifts are the same for carrier and pilot
- Reduced current dependence
 - Pilot can be also used as a “dithering” with low beam currents
- The pilot position returns a diagnostic of the system status
 - Hardware faults can be identified
- References:
 - G. Brajnik, et al., “A novel electron-BPM front end with sub-micron resolution based on pilot-tone compensation: test results with beam.”, IBIC’16.
 - G. Brajnik et al., “Reducing current dependence in position measurements of BPM-systems by using pilot tone: quasi-constant power approach.”, IBIC’17.
 - R. De Monte et al., “Integration of a novel BPM system within the global orbit feedback environment of Elettra.”, DEELS’18.

- Modular approach:
 - Analog front end in machine tunnel
 - Digitiser in service area

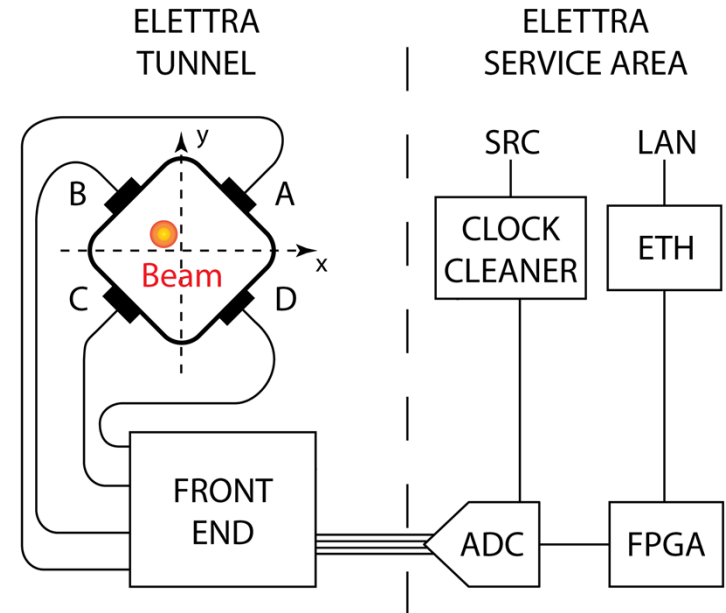
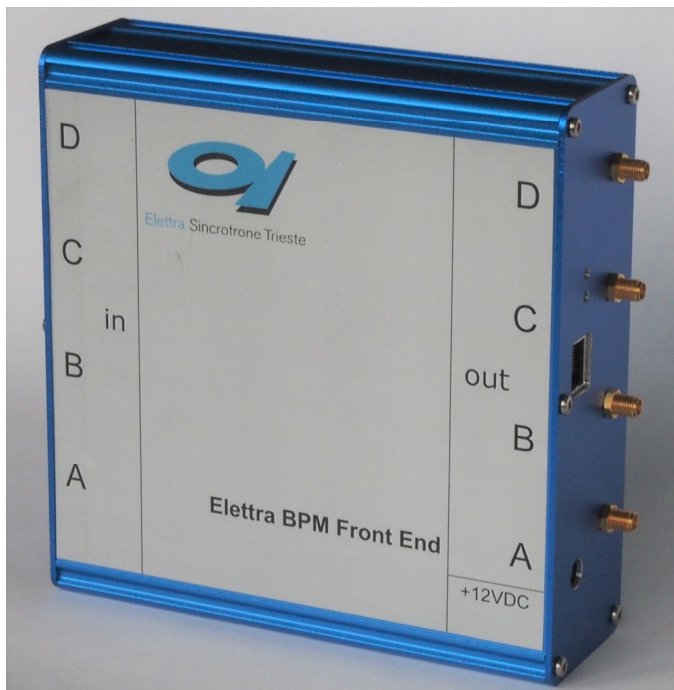

- Analog front end
 - Low noise figure
 - Generation and injection of pilot tone
 - Variable gain
 - Ethernet controlled / PoE capable



Front end block diagram

High isolation couplers

Bandpass filters, BW~10MHz

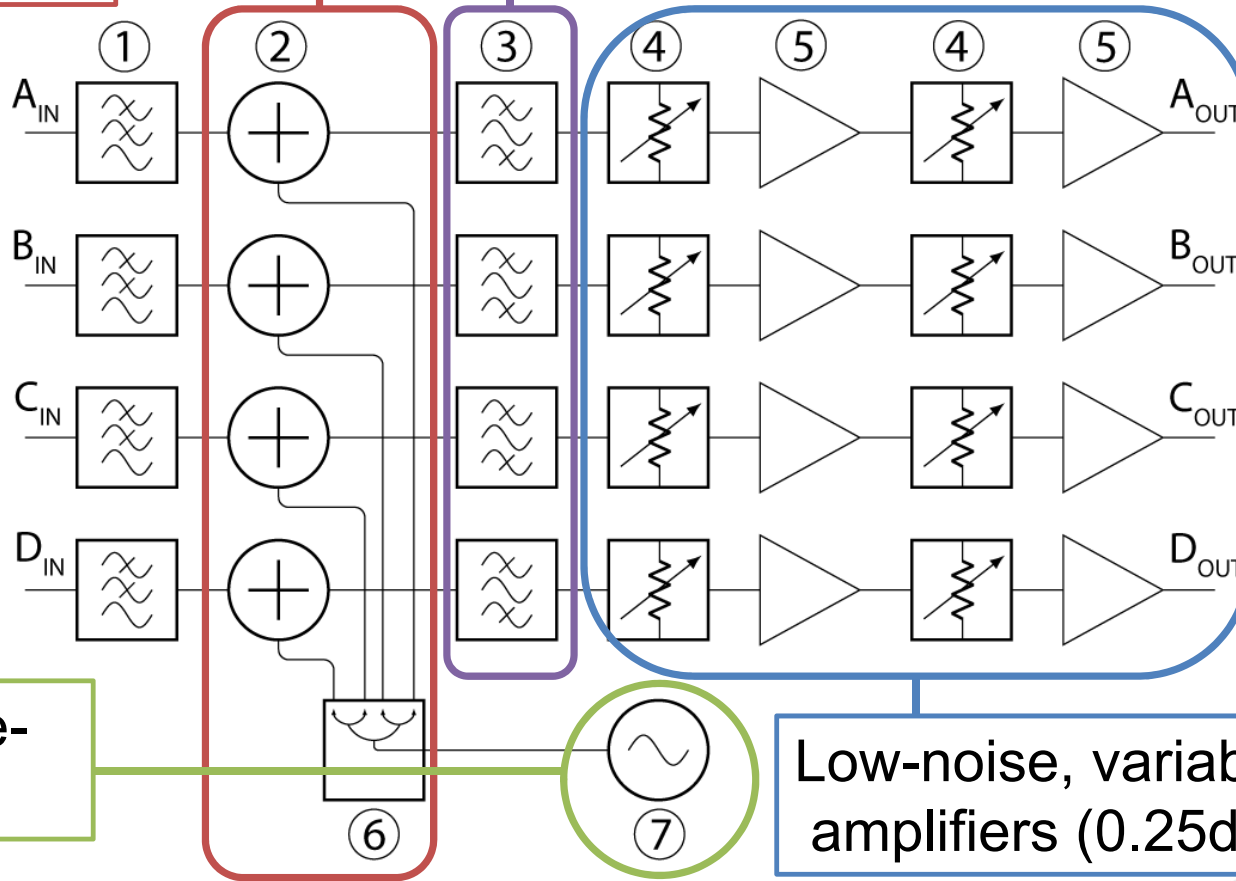

Low phase-noise PLL

Low-noise, variable-gain amplifiers (0.25dB steps)

eBPM with Pilot tone at Elettra

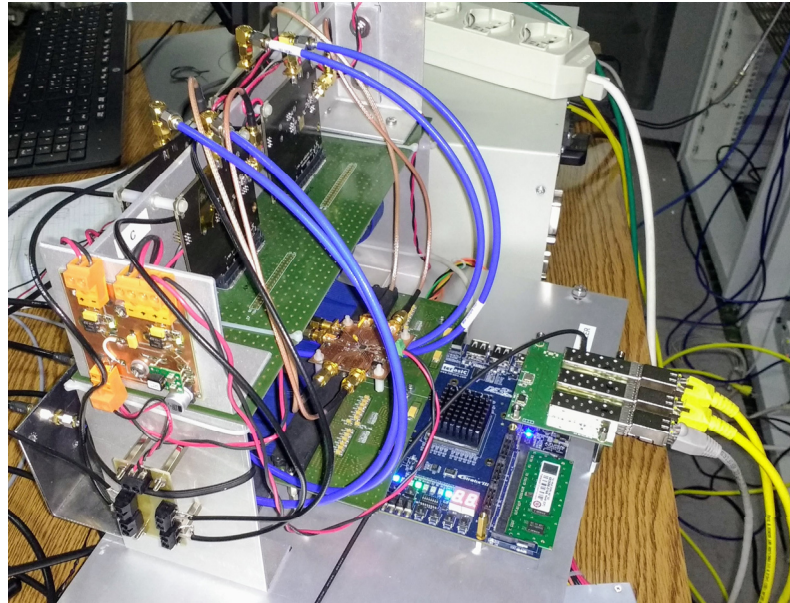

■ Digitiser

- High speed ADCs (160 MS/s, 16bit) working in undersampling
- Double digital receiver in FPGA (Altera Stratix III)
- Continuous and parallel demodulation of both carrier and pilot
- Compensation on GOF data (Global Orbit Feedback, 10 kHz)
- SFP communication with Gigabit Ethernet



FPGA block diagram

Parallel
data
processing

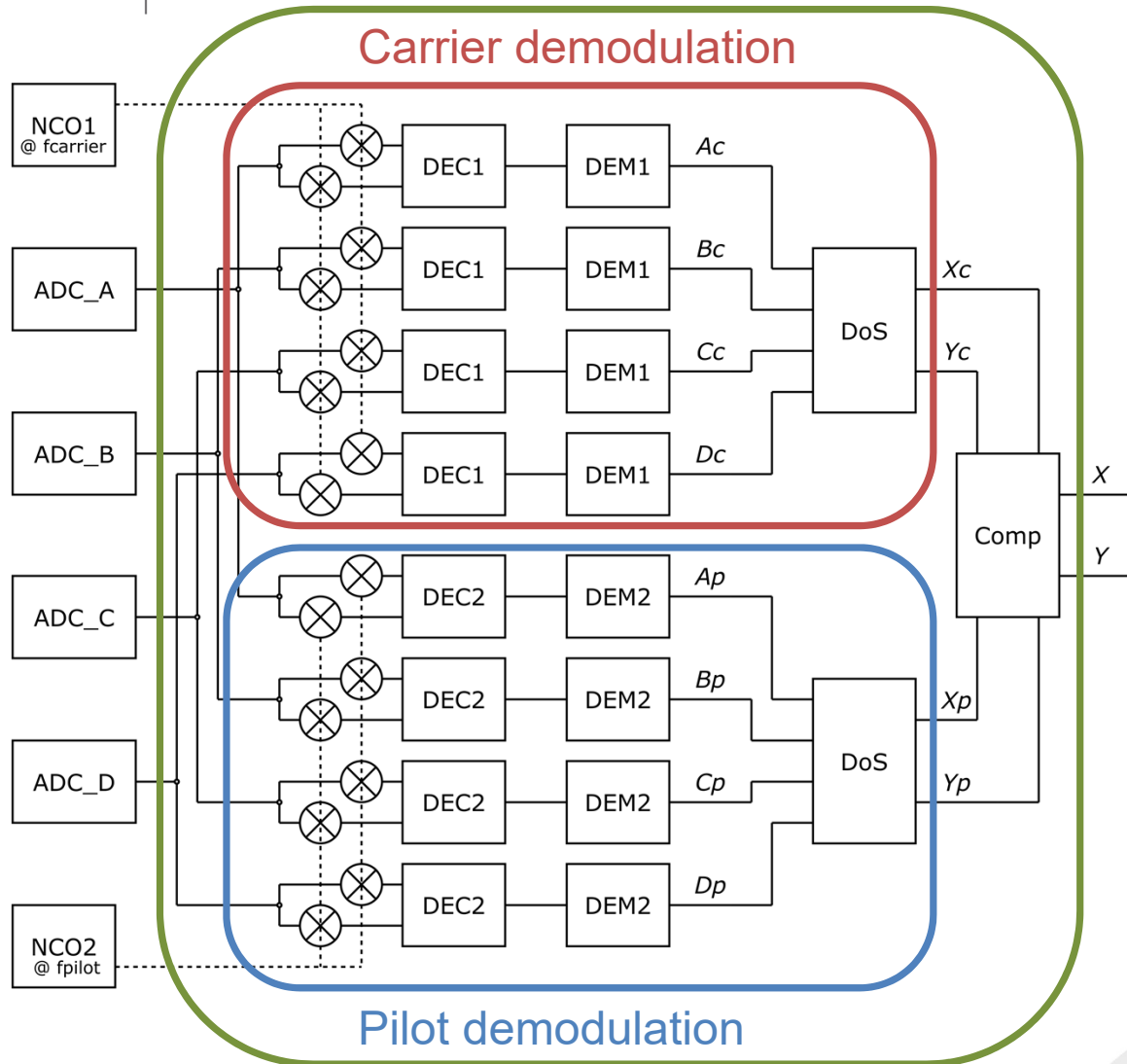

Spectral coherence

Definition:

$$C_{Y_C Y_P}(f) = \frac{|G_{Y_C Y_P}|^2}{G_{Y_C Y_C}(f) G_{Y_P Y_P}(f)}$$

It is a measure of the correlation between carrier and pilot positions

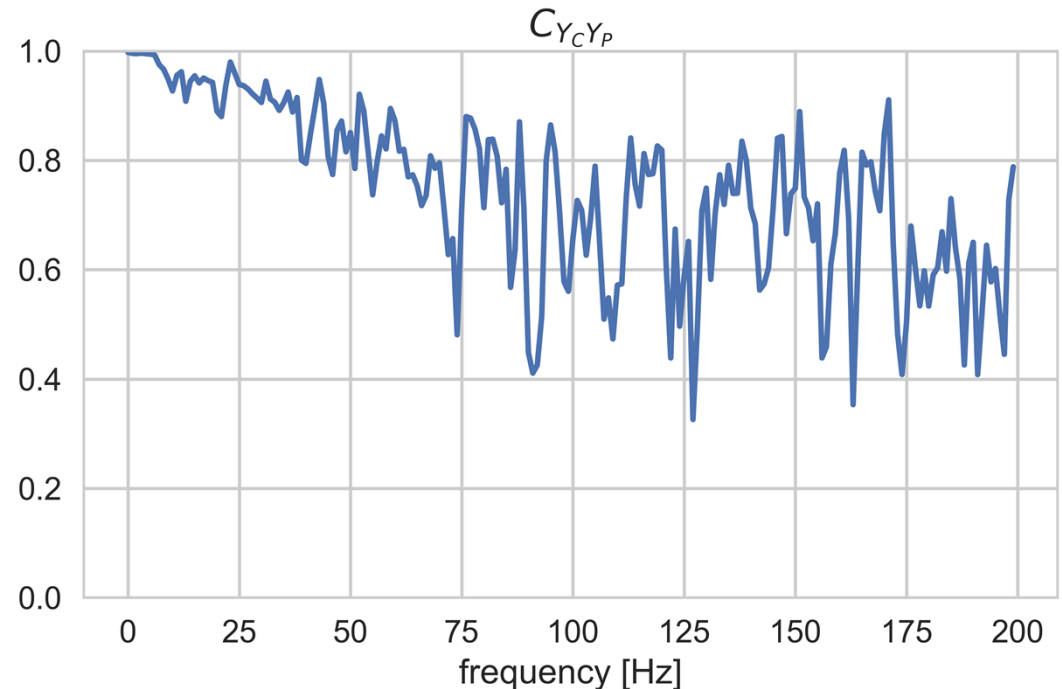

Verify the hypothesis stated in slide 6: *every channel variation affects in the same way both the carrier and the pilot*

Good coherence up to 50/70 Hz: useful for «slow» compensation

- Setup scheme for reference measurements:
 - RF generator that emulates the beam plus a 4-way splitter
 - RF frequency = 499.654 MHz
 - Pilot frequency = 502.051 MHz
- Performances with $K=20$ mm, ADC @ 80% FS:
 - With a RF generator directly at ADCs input: 50 nm sd @ 10 kHz
 - Real conditions (Elettra beam + front end + cables) with 300mA and 2 GeV: ~180 nm sd @ 10 kHz
- Compensation of temperature changes and cables:
improvement at least of a factor of 4 on position drift



Temperature compensation

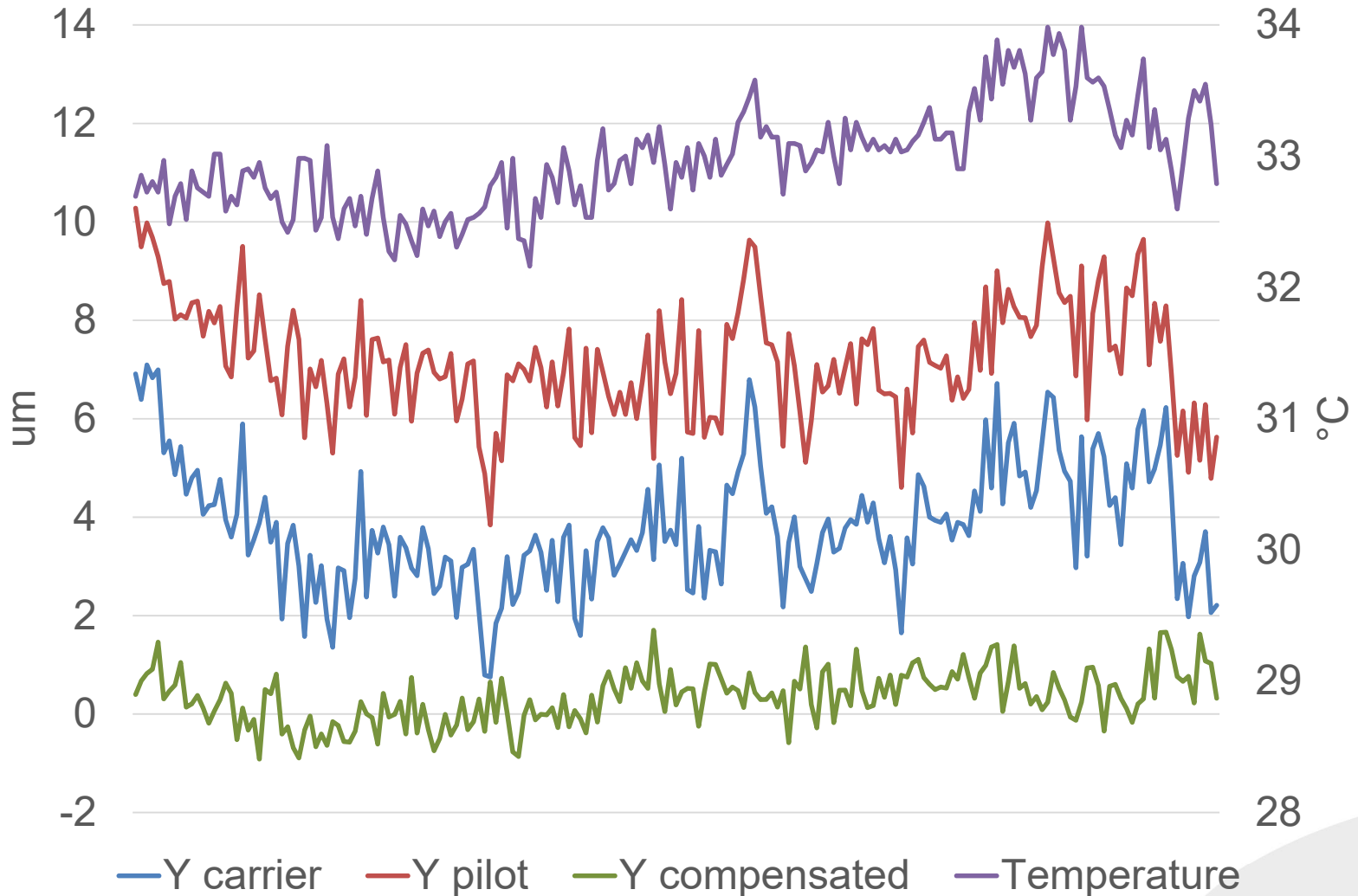

Change in ADC temperature – ch. D

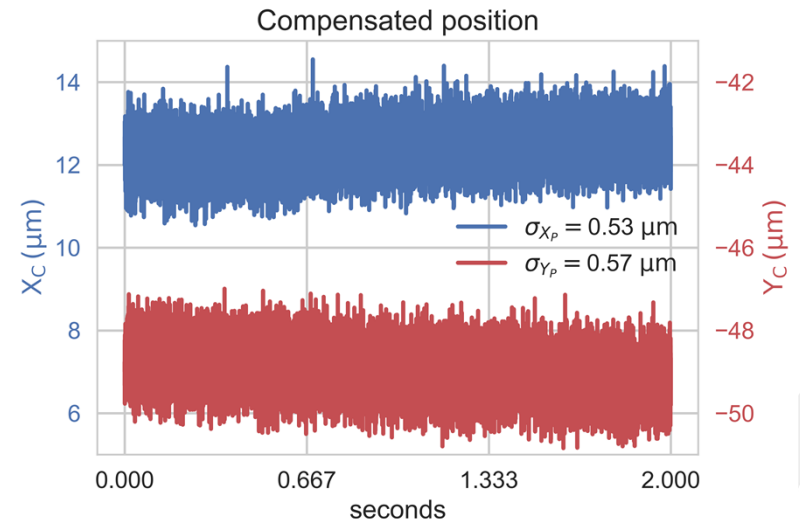
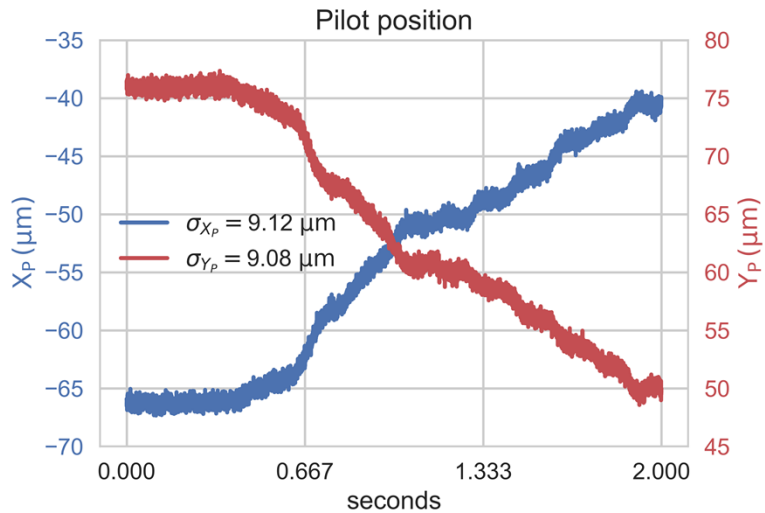
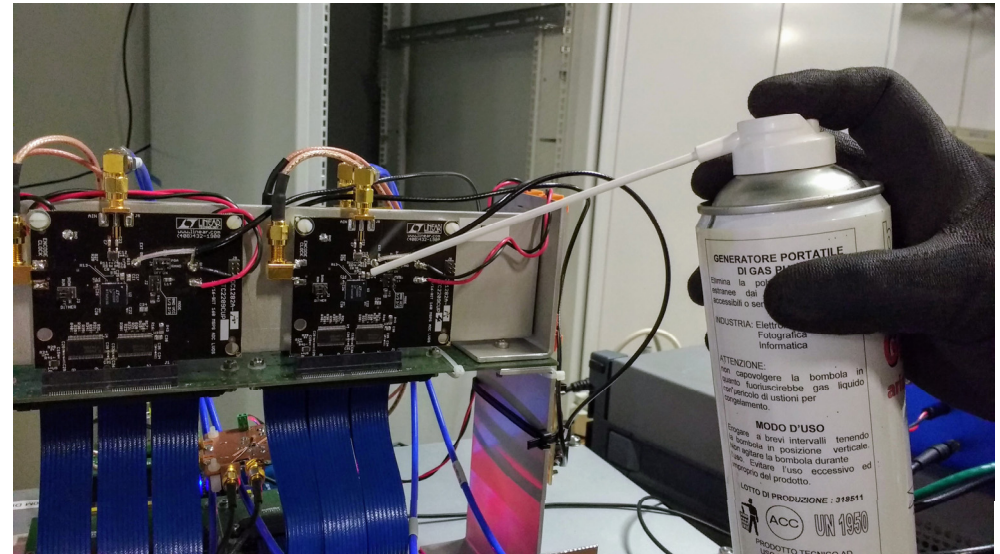
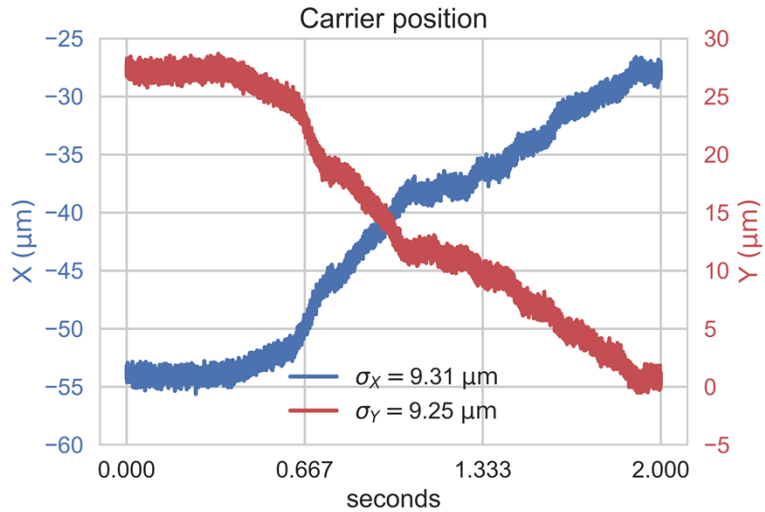

Wobbling of cables – ch. D

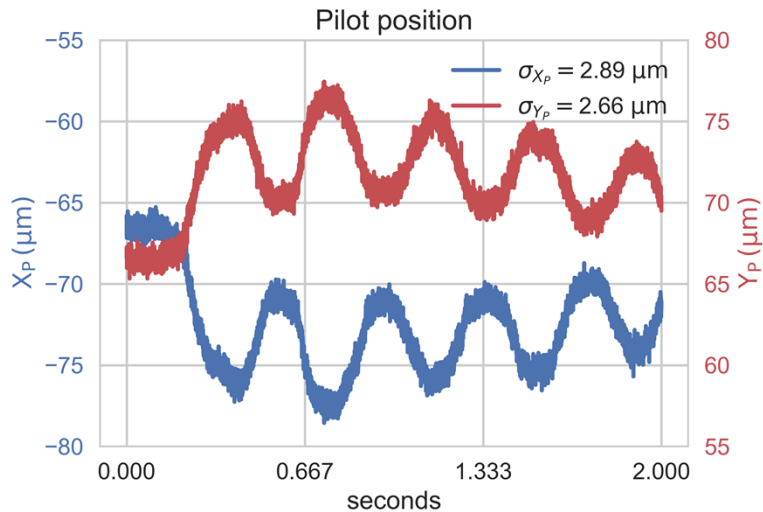
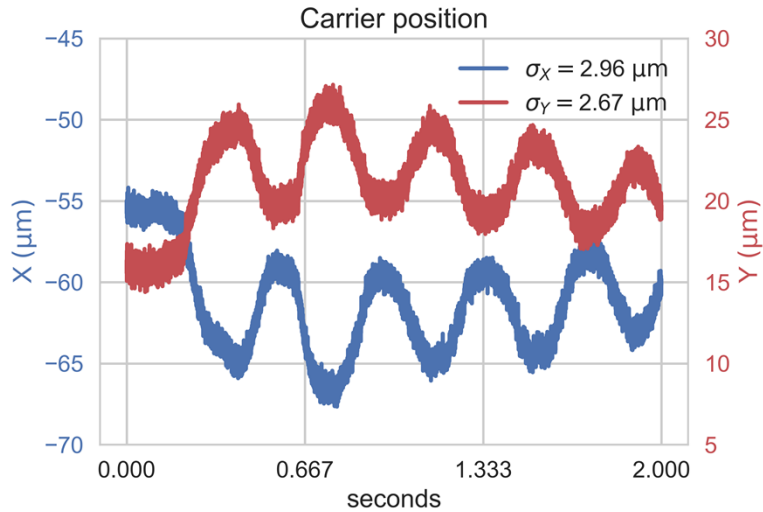

Residual oscillations

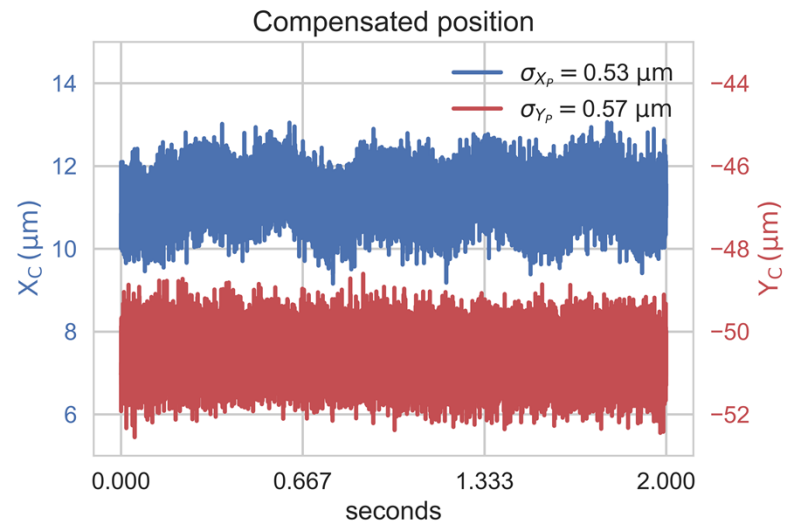

- Complete replacement of a Libera Electron unit:
 - Connection to machine revolution clock (**SRC**), 1.156 MHz
 - Both ADC clock and FPGA processing are synchronous to SRC
 - Gigabit Ethernet link to Global Orbit Feedback (**GOF**)
 - Due to a different internal processing, there is a difference of 0.02 Hz between 10 kHz data from the Libera and the prototype: solved using the replaced unit as a trigger
 - Second Ethernet link for Tango Server/housekeeping
 - A porting of the standard Tango BPM server was installed on a Linux VM that communicates with the prototype, calculating slow data and handling AGC/pilot amplitude

Complete block diagram

ELETTRA TUNNEL

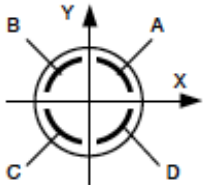

Beam signals

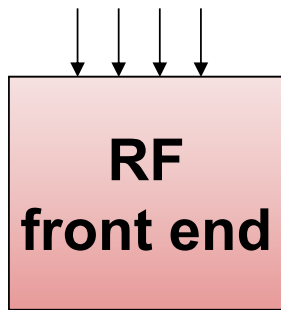

ELETTRA SERVICE AREA

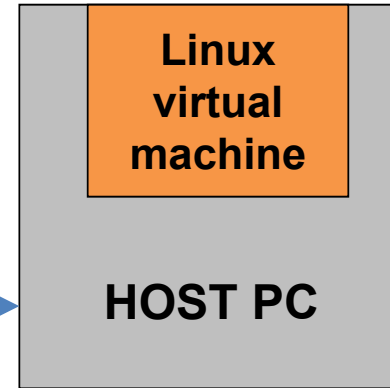
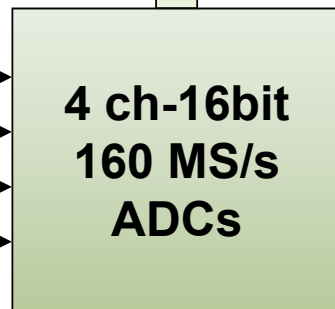
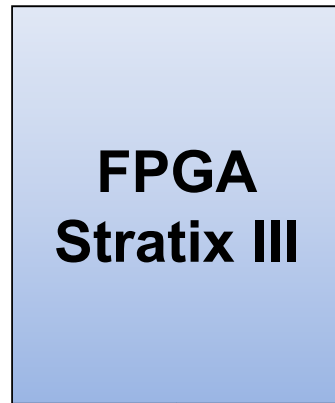

Tango server

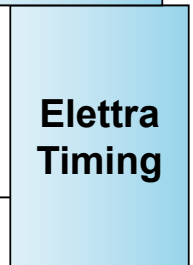
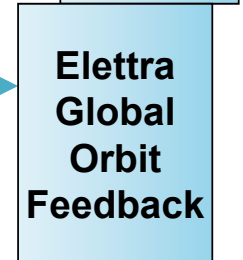
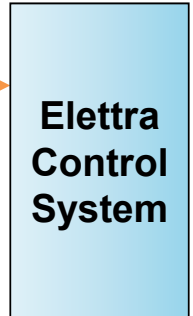

CMDS and DATA

GOF DATA – 10 kHz
GOF DATA Trigger

ADC clock

Revolution clock

Linux VM: data path and process structure

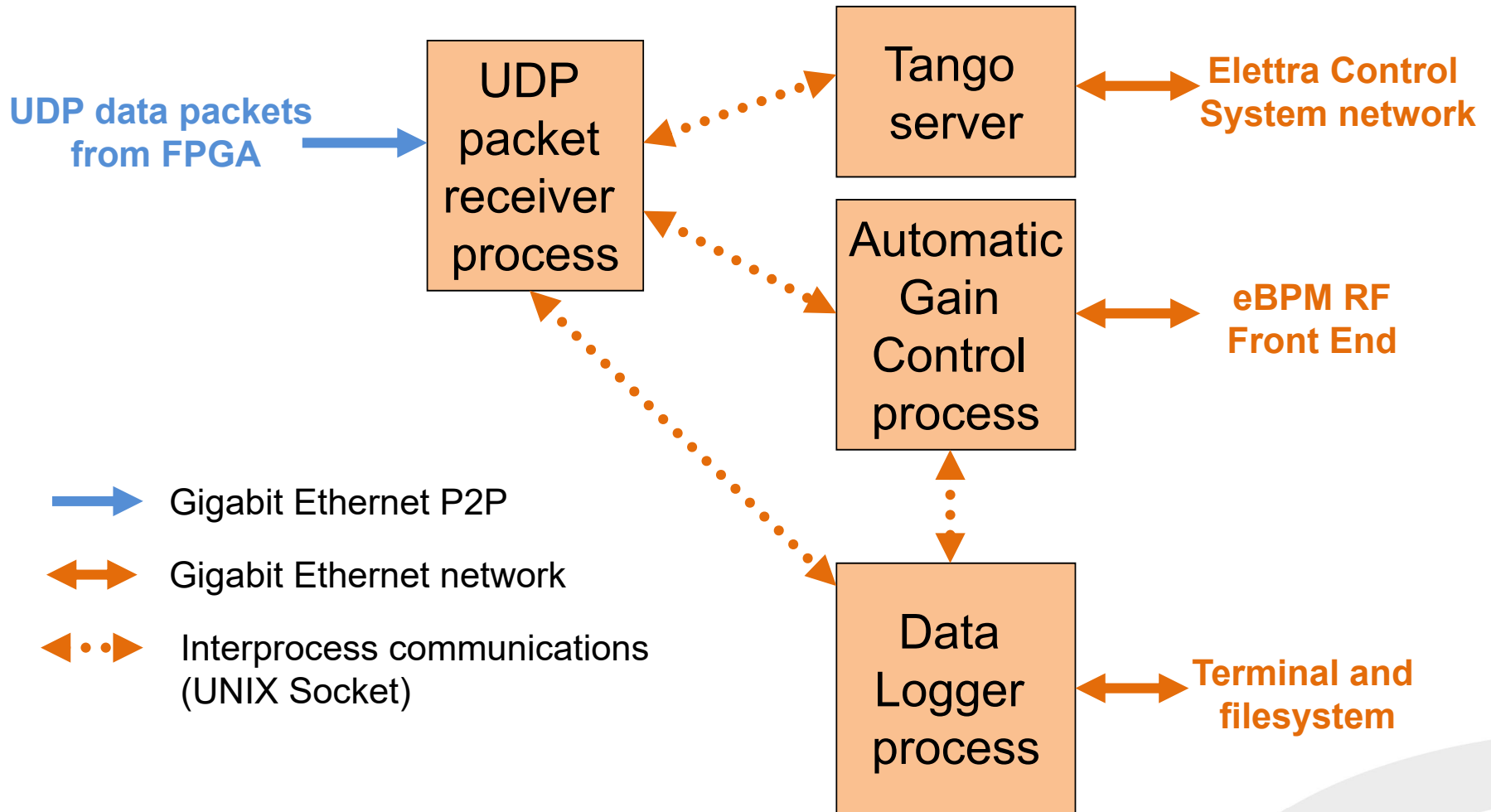

Overall system in Elettra Service Area

Elettra Service Area

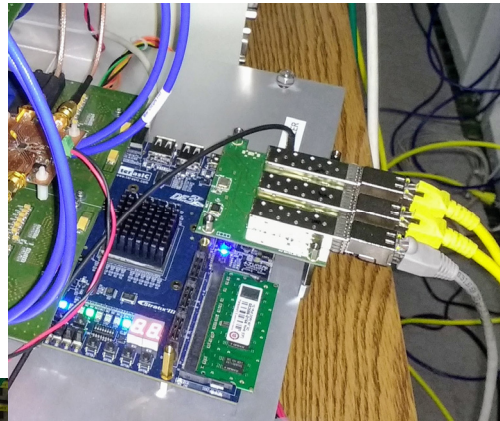
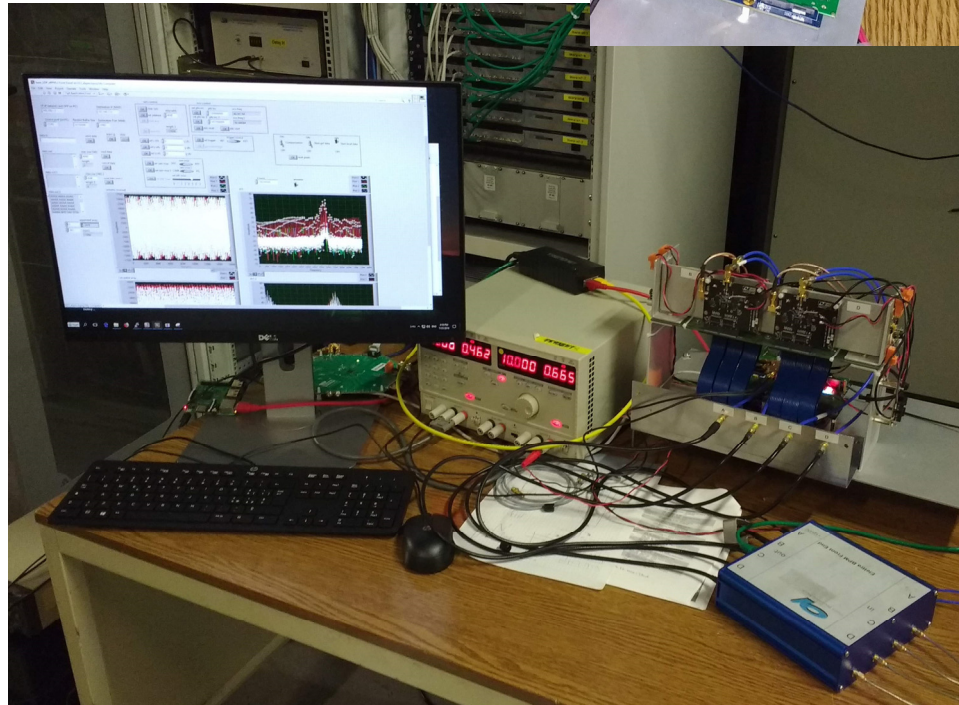

FPGA and
Gigabit Ethernet
detail



Elettra Tunnel

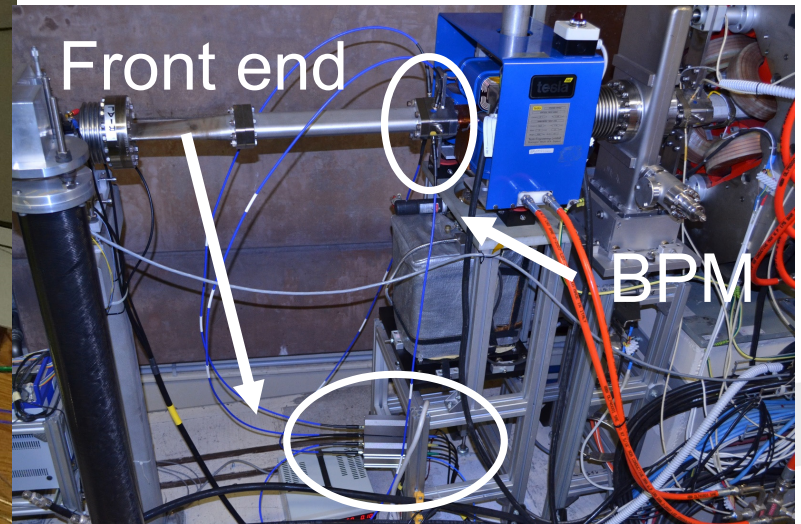

Data logger output: 300 mA, 2.0 GeV

Started 18-2-2018 22:7:18 logging to file GofON_1min_mean60_quat.xlt Now 3 loglines 18-2-2018 22:10:21

Va =	43065835.4	RMS	21599.18
Vb =	51906701.7	RMS	27025.16
Vc =	55702573.9	RMS	25403.22
Vd =	46934320.0	RMS	29354.82
Sum =	197609431.1	RMS	14998.18
Q =	-7236.0	RMS	691.59
Xum =	-1754.591	RMS	10.09
Yum =	-754.764	RMS	1.55

← Beam parameters

PVa =	53451318.7	RMS	1755.58
PVb =	54265351.1	RMS	1741.43
PVc =	53870777.4	RMS	1690.61
PVd =	53693140.5	RMS	1715.98
PSum =	215280587.7	RMS	5948.55
PQ =	-58206.8	RMS	184.56
PXum =	-90.701	RMS	0.18
PYum =	13.807	RMS	0.18

← Pilot parameters

← *Quality of measure*

Compensated Xum =	-1663.890	TangoXum =	-771.690	Xoffset=	892.200
Compensated Yum =	-768.571	TangoYum =	119.429	Yoffset=	888.000

att A 0=	4	1=	94
att B 0=	4	1=	94
att C 0=	4	1=	94
att D 0=	4	1=	94
att Pil 12	freq=502435897		
Pil out1 4	out2=	9	
TEMP abcd1:	405	407	401 385 412

← Front end parameters



Beam Y-position in a 24-hours time window

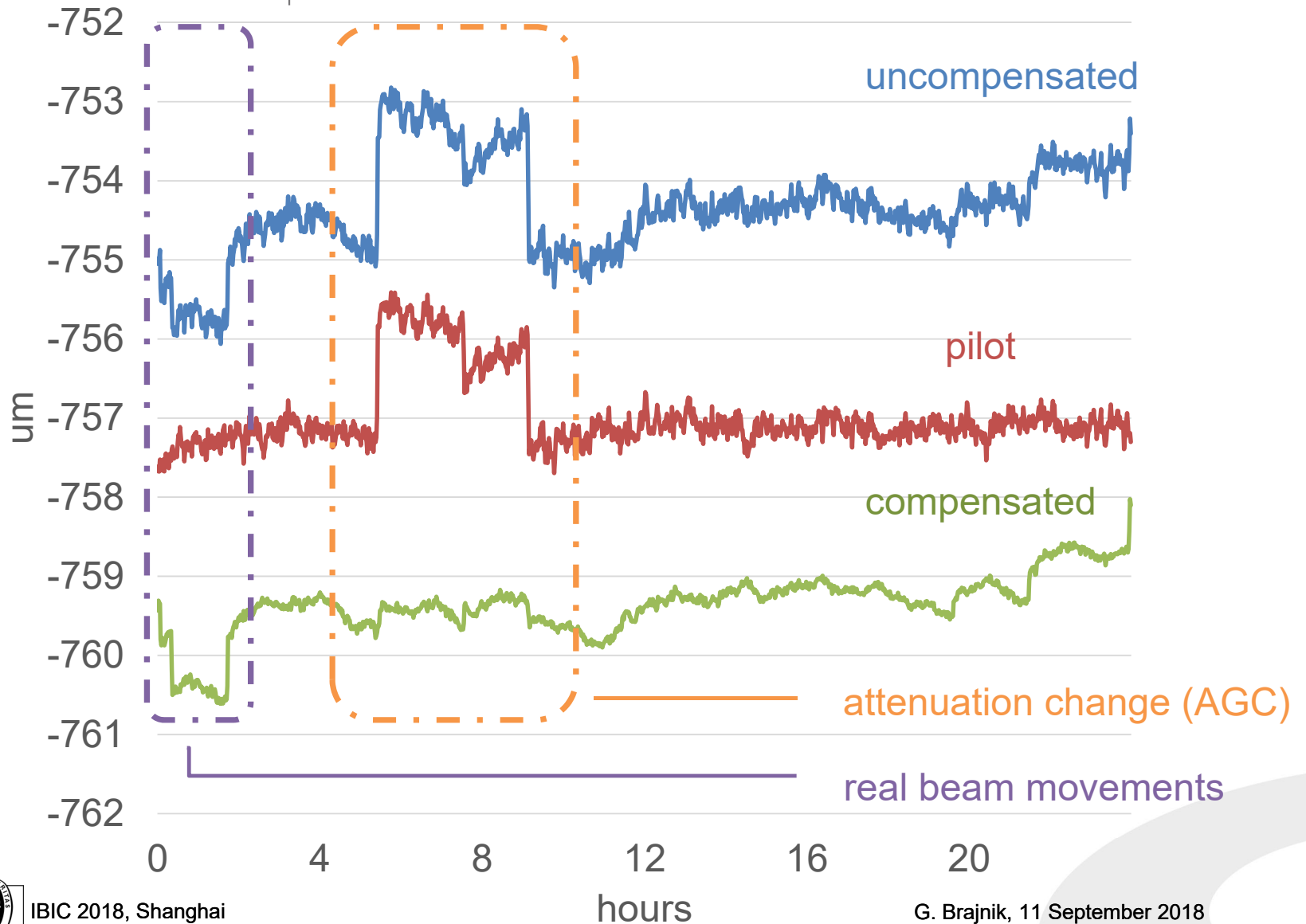

Self-diagnosis using pilot

Having a well-known pilot signal can help in detecting hardware problems. Here is an example of "strange" behaviour during an 8-hour acquisition: channel C demodulated amplitude was different from the others.

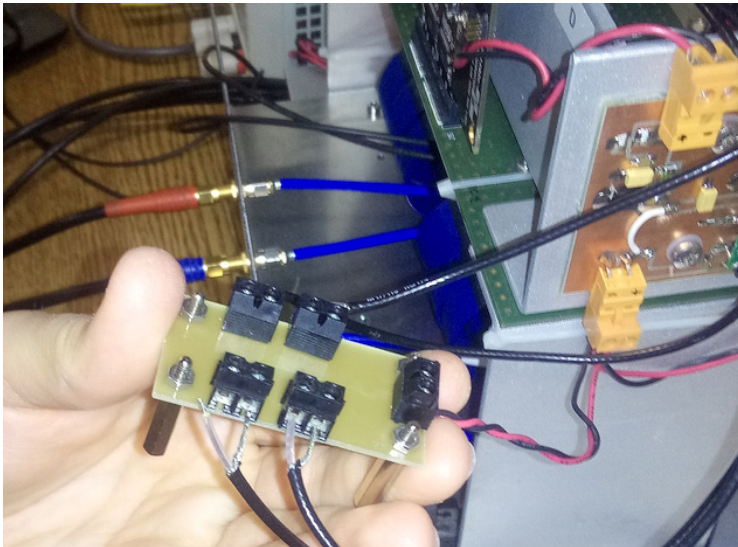
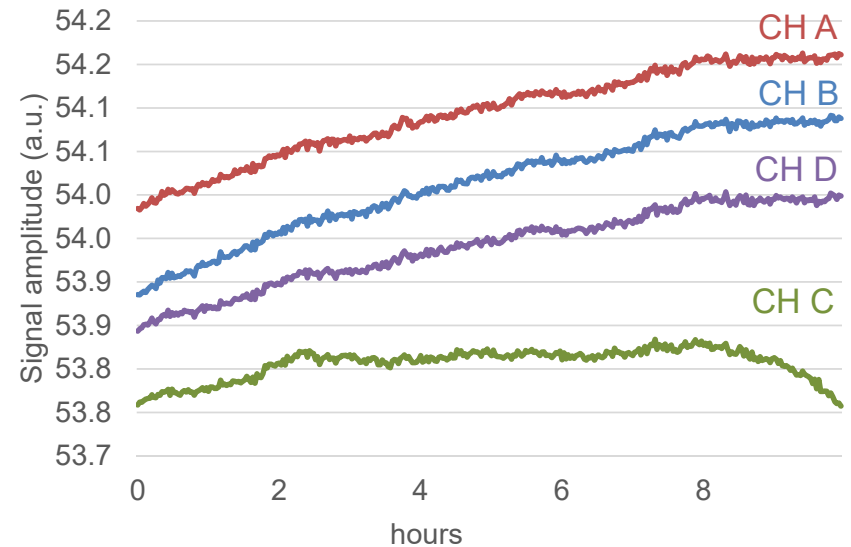

The common reference voltage for the ADCs had a broken contact: so ADC C was using the internal reference voltage rather than the common external one, causing the unexpected drift.

- A prototype of a new eBPM using “pilot tone” has been successfully tested on Elettra machine during **dedicated and user shifts** with no issues:
 - **Resolution better than 200nm @10 kHz**
 - **Long-term stability better than 500nm in 12 hours**
 - **Active compensation of temperature, cables and channels differences; on-line diagnostic is possible**
- Further developments:
 - Frequency-hopping pilot to better estimate the channel response
 - Different filtering for pilot tone (narrow bandwidth)
- Coupling of Elettra front end with I-Tech’s Libera Spark
 - **See poster TUPB13 and I-Tech booth for a live demo**

Thank you!



Elettra
Sincrotrone
Trieste



www.elettra.eu