

Gyrotron Based Systems for Electron Cyclotron Resonance Ion Sources

G.G. Denisov^{1,2}, M.Yu. Glyavin^{1,2}, Yu.V. Bykov¹, A.I. Tsvetkov¹, A.G. Ereemeev¹,
V.V. Holoptsev¹, I.V. Plotnikov¹, E.A. Kopelovich¹, A.G. Luchinin¹, M.V. Morozkin¹,
M.Yu. Shmelev¹, D.I. Sobolev¹, M.M. Troitsky¹, A.A. Bogdashov¹, M.I. Bakulin²,
M.D. Proyavin¹, E.V. Sokolov², E.A. Soluyanova^{1,2}, E.M. Tai^{1,2}

tsvetkov@ipfran.ru



¹ Institute of Applied Physics, RAS



² GYCOM Ltd.

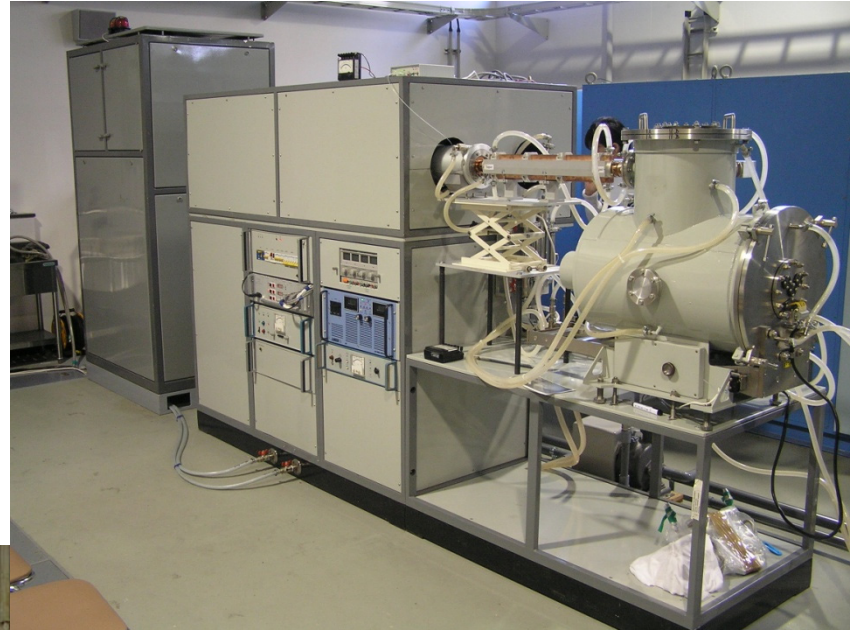

Gyrotron-based systems - examples

Gycom/IAP RAS Technological Setups

Typical efficiency of gyrotrons used in the systems is **30%**.

F, GHz	P, kW	Mode	Max U(kV) / I(A)
24	3	TE₁₁	15 / 1
24	10	TE₁₂	20 / 1
24 PM	5	TE₁₂	20 / 1
28	15	TE₀₂	25 / 2.4
30	15	TE₀₂	25 / 2.0
300 Cryo	2.3	TE_{22 8}	15 / 1

PM – permanent magnet
Cryo - cryomagnet

Efficiency of the system

$$\eta = \frac{P_{MW}}{P_{HVPS} + P_{sol} + P_{aux}} = \eta_{gyr} \eta_{tr} \eta_{HVPS} \frac{1}{1 + \frac{P_{sol}}{P_{HVPS}} + \frac{P_{aux}}{P_{HVPS}}}$$



Permanent magnet



Example: Two models of HVPS
in DC and pulse regimes
(eff. ~ 0.95)
- 20 kV & 1.0 A
- 25 kV & 2.4 A



Efficiency of the millimeter-wave power transport through oversized transmission lines is 0.95-0.98. Very advanced synthesis codes are used for the design of TL

GYROTRON SYSTEM FOR MICROWAVE PROCESSING OF MATERIALS

3 kW / 24 GHz gyrotron system



Volumetric heating

Surface heating
in focused wave beam

- Output power **2.5-3 kW**
- Frequency **24 GHz**
- Applicator volume **$\sim 0.1 \text{ m}^3$**
- Multi-channel temperature measurement system with an accuracy of **$\pm 0.2\%$ at $T \sim 2000 \text{ }^\circ\text{C}$**
- Computerized system of process control
- Gas pressure **$(10^{-5} \div 2) \text{ Torr}$**
- Life time – **10 years at FIR FU**



10 kW / 24 GHz gyrotron system

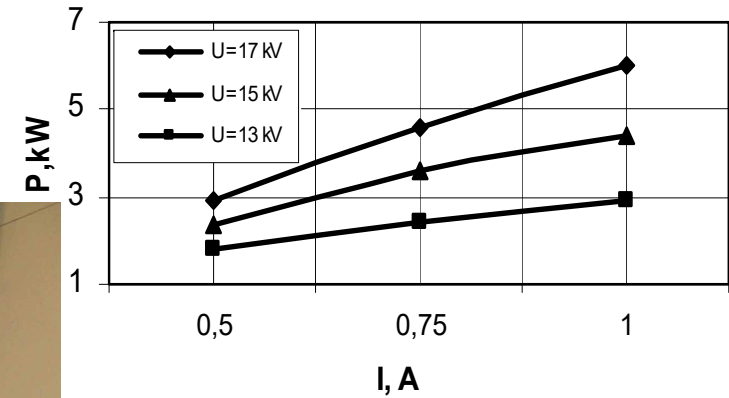
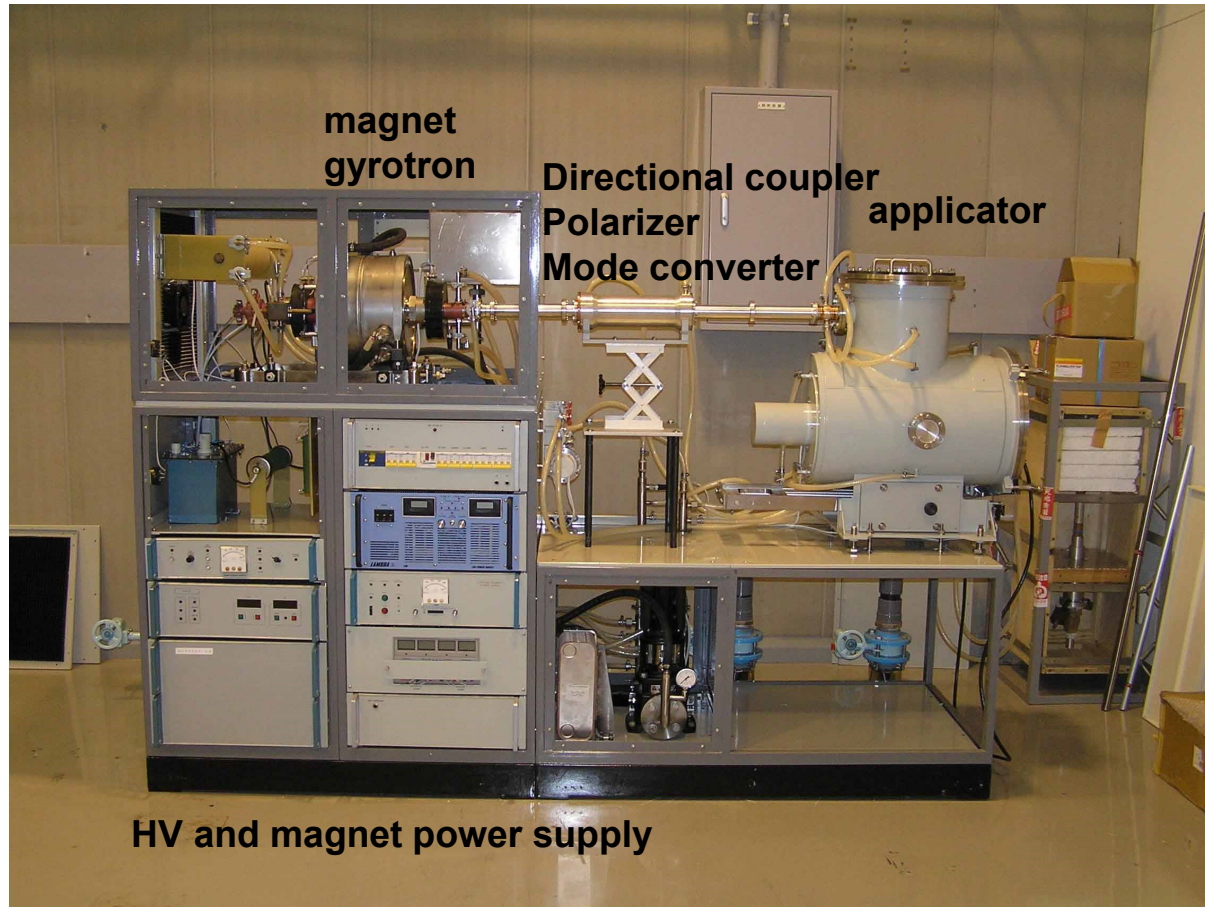

- **Gyrotron power supply**
voltage up to 20 kV
current up to 1 A

- **Main solenoid**
current less than 90 A
voltage less than 100 V

- **Power consumption**
up to 35 kW

Dual source system: 28 GHz / 15 kW gyrotron & 2.5 kW frequency tunable gyro-BWO (24 GHz)

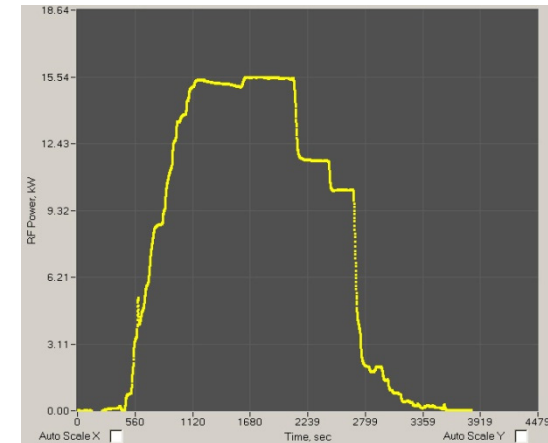
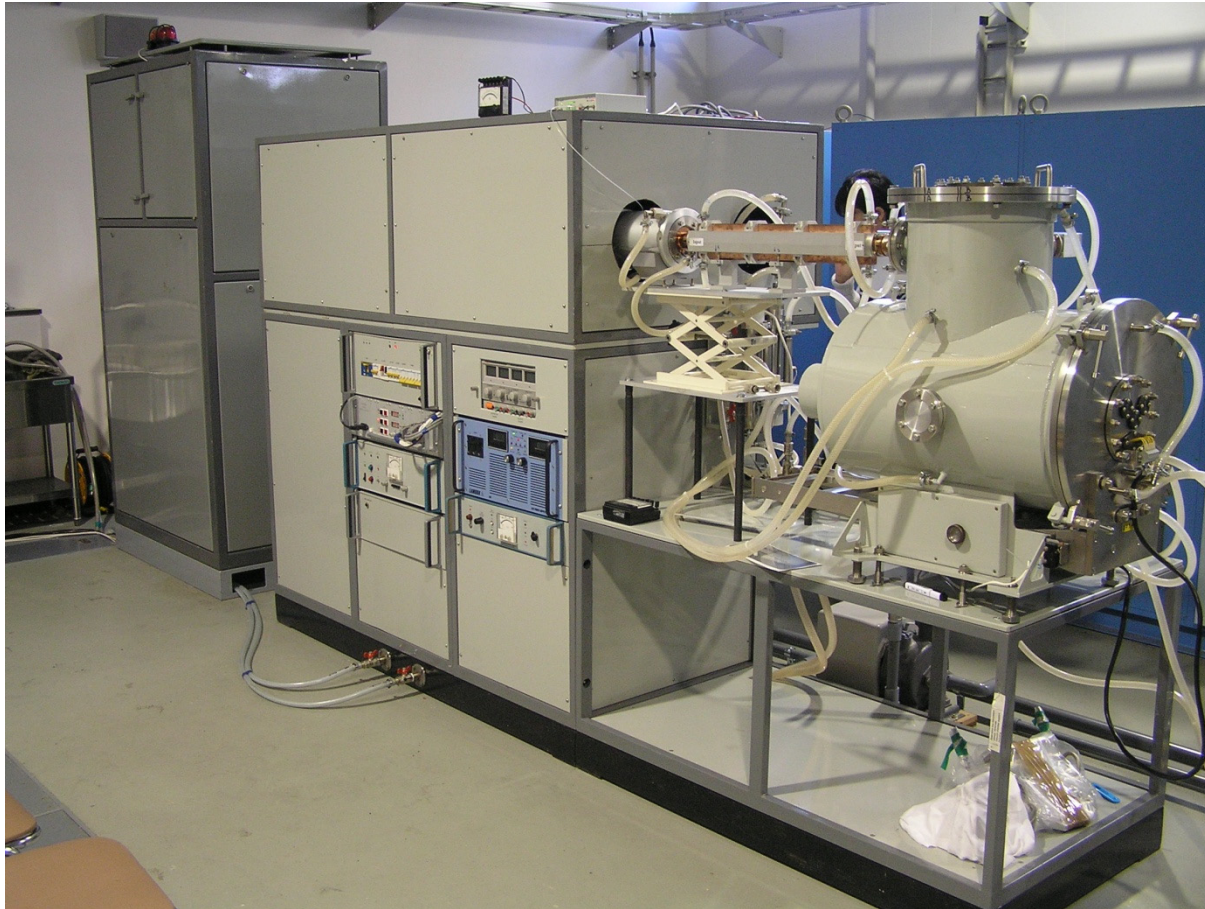

SIMULATION RESULTS

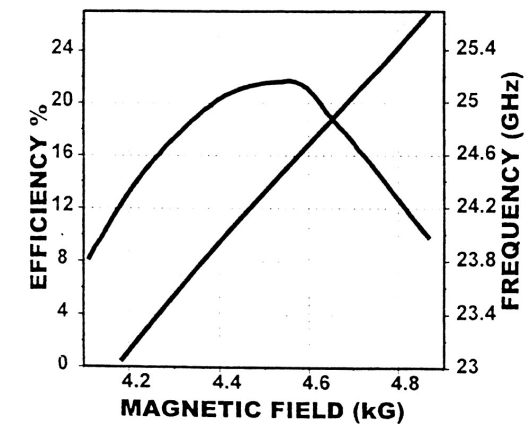

Technological gyrotron with CPD collector

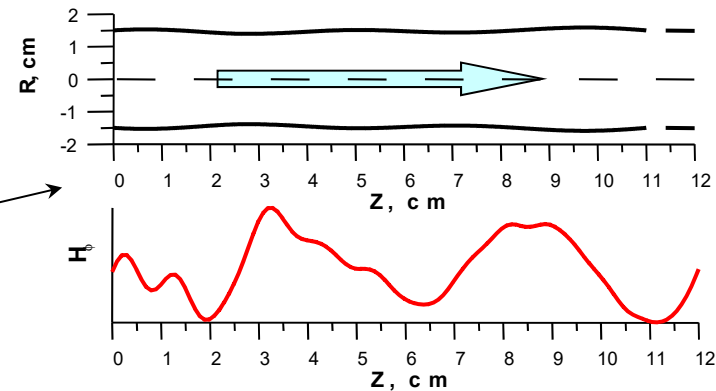
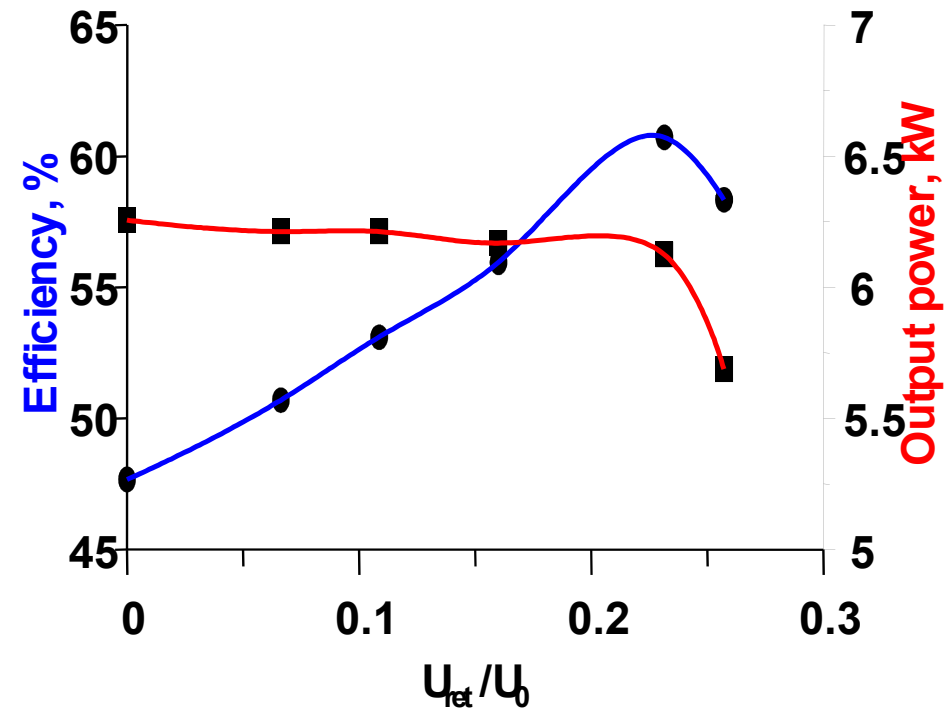
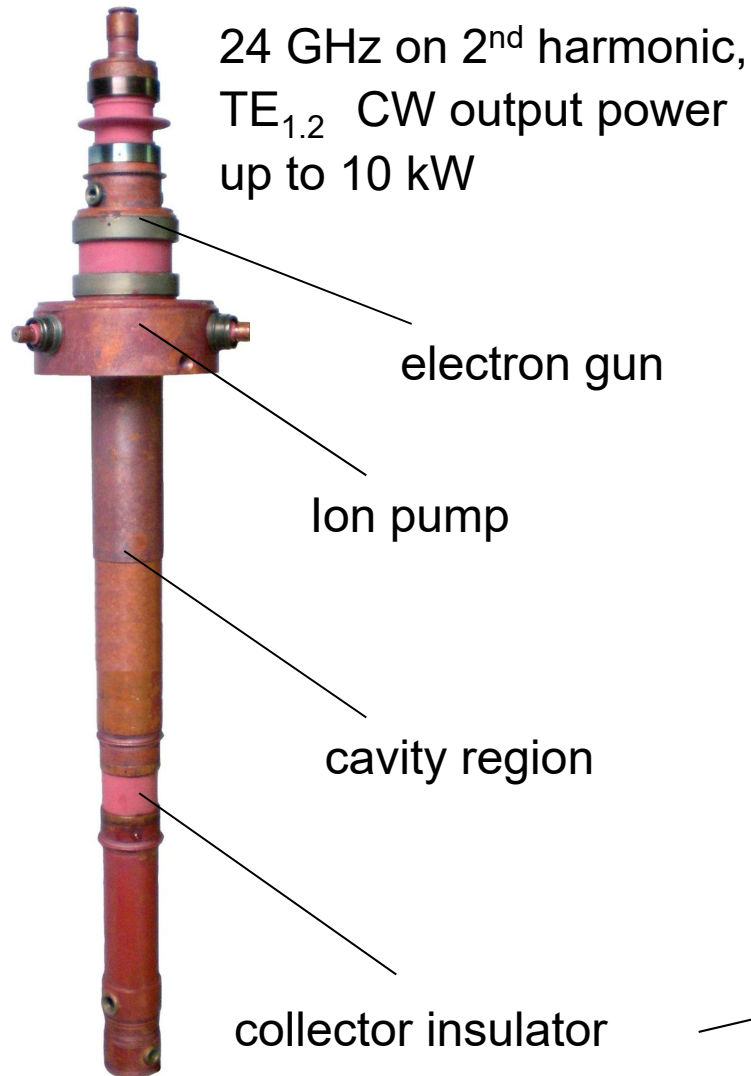

Control of gyrotron frequency

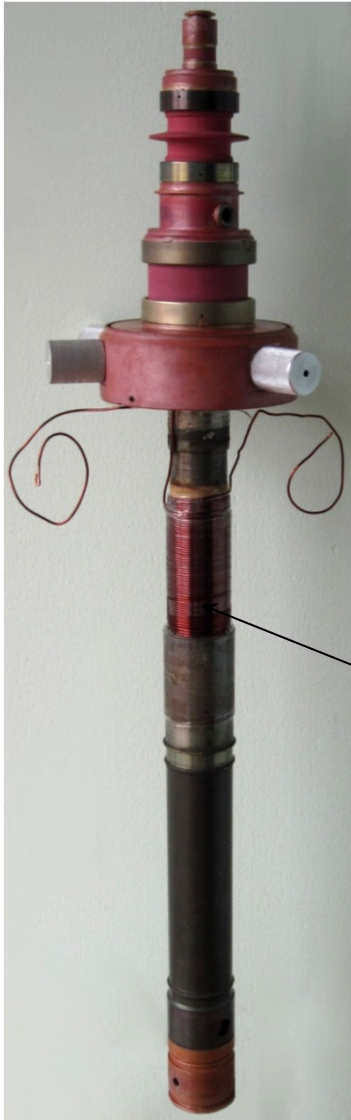

Auxiliary coil with power consumption $\sim 1W$

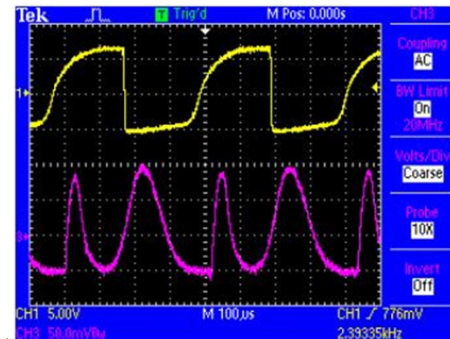
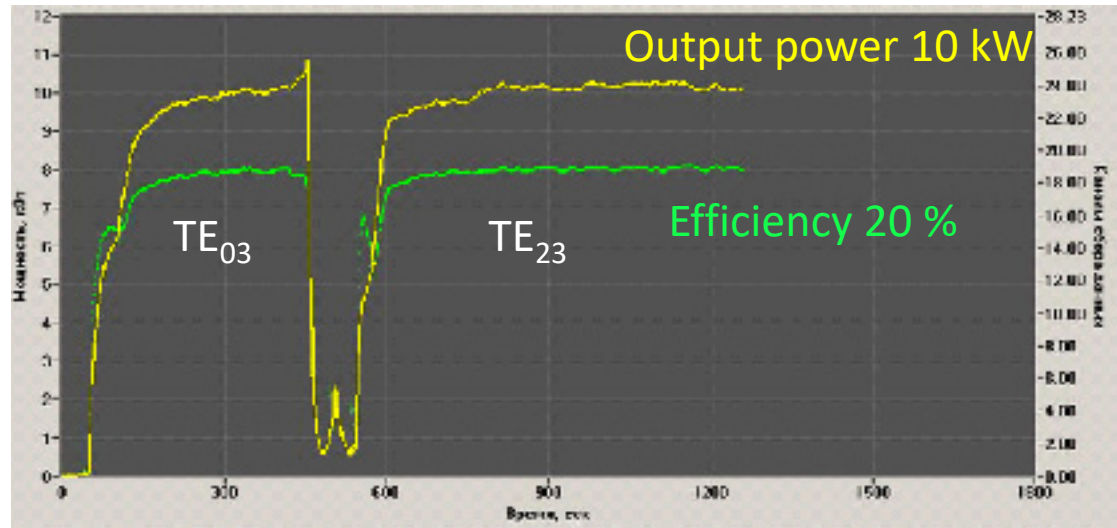

- Auxiliary coil current
- microwave power from the RF detector

28.1 GHz

$T \sim 400 \mu s$

28.7 GHz

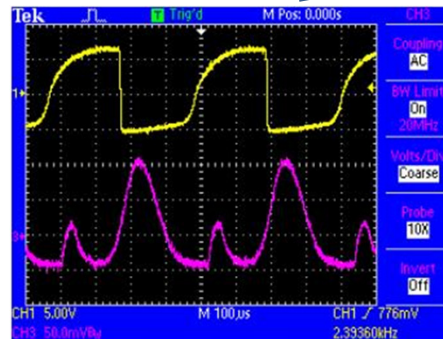

resonance absorption

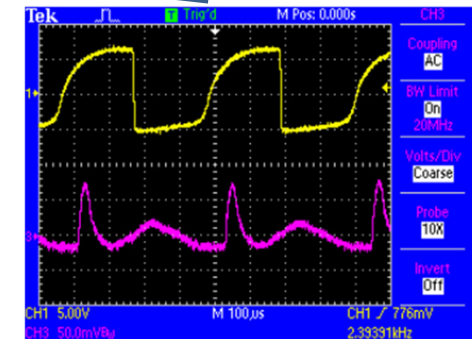

Fast power modulation

Microwave power

Aux coil current

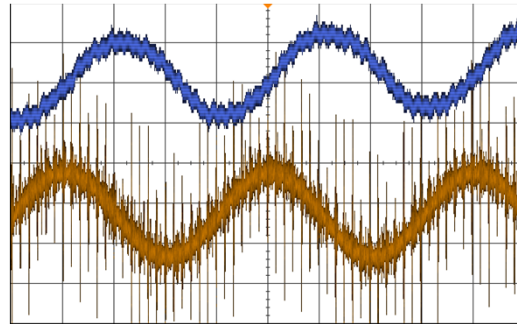

5 kHz

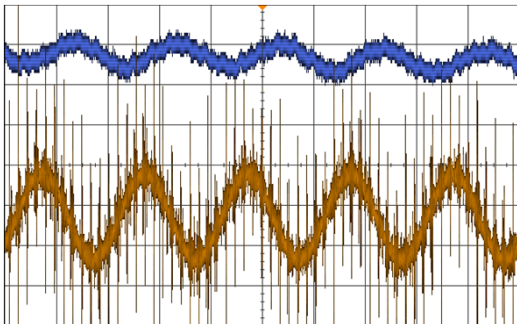

10 kHz

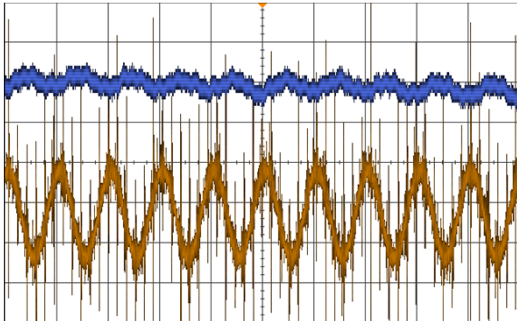

20 kHz

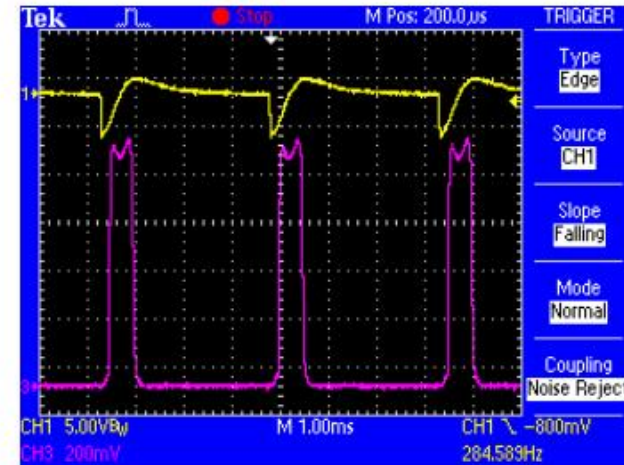

TDS 2014 - 16:05:10 28.03.2011

Depth of modulation decreases with increasing frequency due to skin effect. Maximum power modulation frequency in our system is about 20 kHz.

Example: quasi-optical mode converter $TE_{0,3}$ (28.7 GHz), $TE_{2,3}$ (28.1 GHz) \rightarrow TEM_{00}

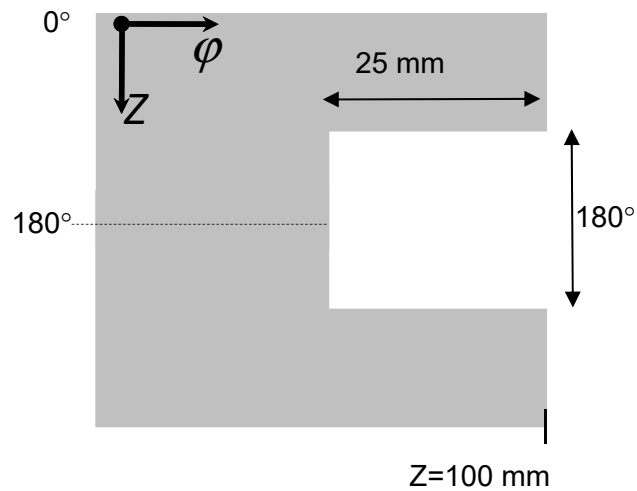

	$TE_{0,3}$	$TE_{2,3}$
$\eta_{a,\varphi}$ - content of TEM_{00} in the radiated field, %	94,5	93,8
η_a - content of TEM_{00} in the radiated field, nonregistering phase %	97,1	97,4
Fraction of power in the reflected field, %	0.8	1.0
Fraction of power in the cross-polarized field, not less than, %	0.2	0.2

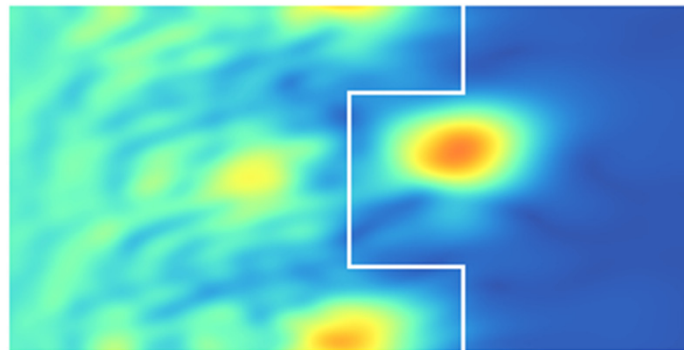

TE_{03}

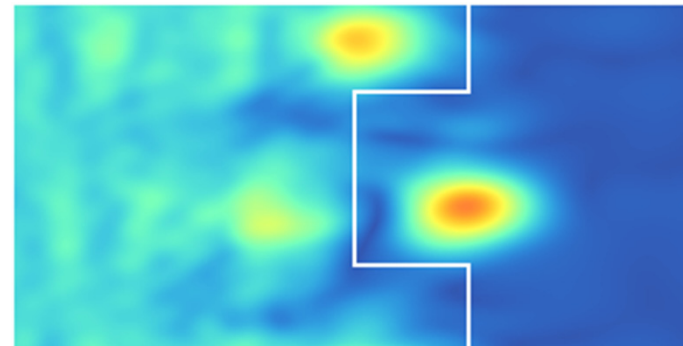

$TE_{2,3}$

Main future goals (infinite task of the high power electronics)

Increasing the operation frequency for ECRIS family

Growth up of the gyrotron power and system efficiency

Shielded magnetic system

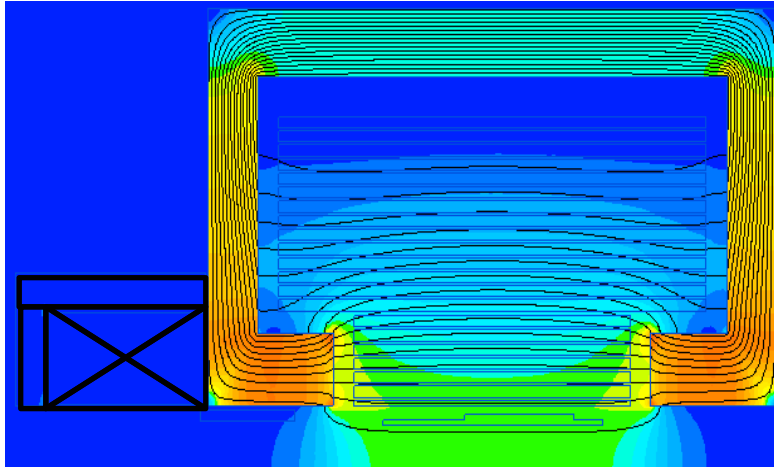

To grow up the magnetic field up to 1.3 T thickness of all shields was increased up to 25-30 cm. Such wide screens have negative impact on the electron-optical system in case of necessary B-field conditions in emitter area.

Map of magnetic field

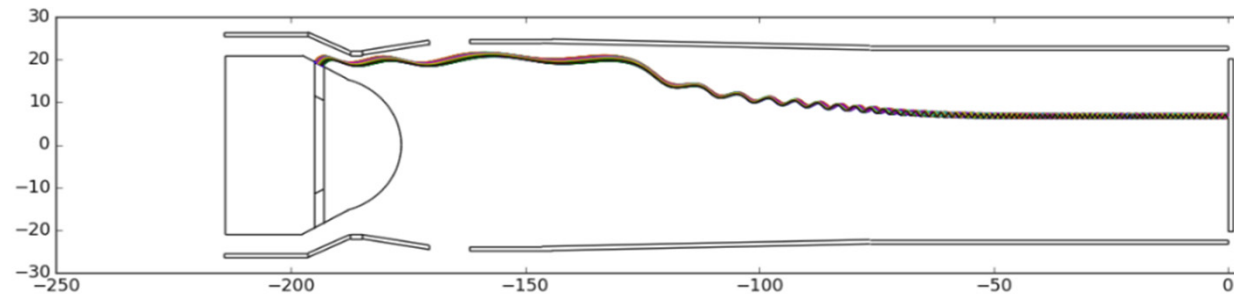

Electron-optics system

The project of 28-30 GHz gyrotron with output power up to 25-30 kW both CW and pulse operation regime are under investigation.

The shield magnet increase the total efficiency to 50%



45 GHz/20kW Gyrotron Setup for the FECRAL Ion Source

Main Requirements to Setup

- 45 GHz frequency
- 20 kW output power in both CW or Pulse regimes
- Pulse mode: 5 - 200 ms duration, $<1 \mu\text{s}$ fall time, up to 10 Hz repetition rate
- 300 kV DC break
- TE01 or TE11 mode at the input of magnetic trap
- Complete system / turnkey setup



Limits for realization – completely new setup

- Contract signed
- Scheme chosen
- System designed
- Setup fabricated
- Setup tested



One year

- Delivered
- Site tests

Microwave power specified
in plasma chamber (!)

Early delivery and test at site

Setup Schematic

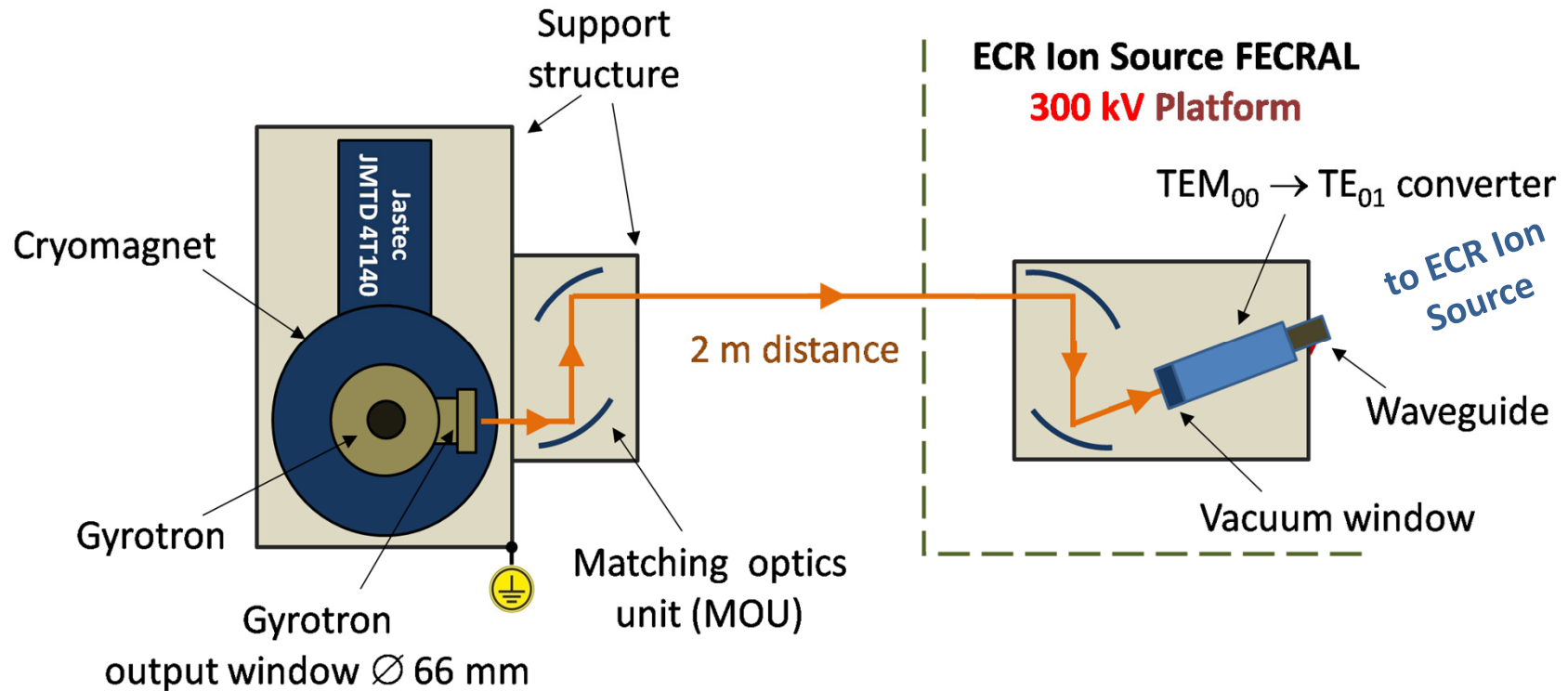

20 kW output power in both **CW or pulse** regimes at **45 GHz** frequency.
Pulse mode: **5 - 200 ms duration**, **~1 μ s fall time**, **up to 10 Hz repetition rate**

Setup Main Features

Plug & Play System

- Gyrotron
- Magnet
- HV PS
- Control System
- QO System
- Cooling and other aix

Advanced Quasi-Optics

- Efficient gyrotron QO
- 300 kV DC break
(2 m beam transmission)
- Unique mode converter
(easy switching between
TE01 or TE11 output)

90% made by IAP/GYCOM

Gyrotron, equipped by Internal Mode Converter



**TE_{6,3} fundamental harmonic operation
45 GHz / 20 kW (CW and Pulse mode)**

The tube is designed to operate with diode-type electron gun (LaB₆ cathode) and depressed collector for electron energy recovery

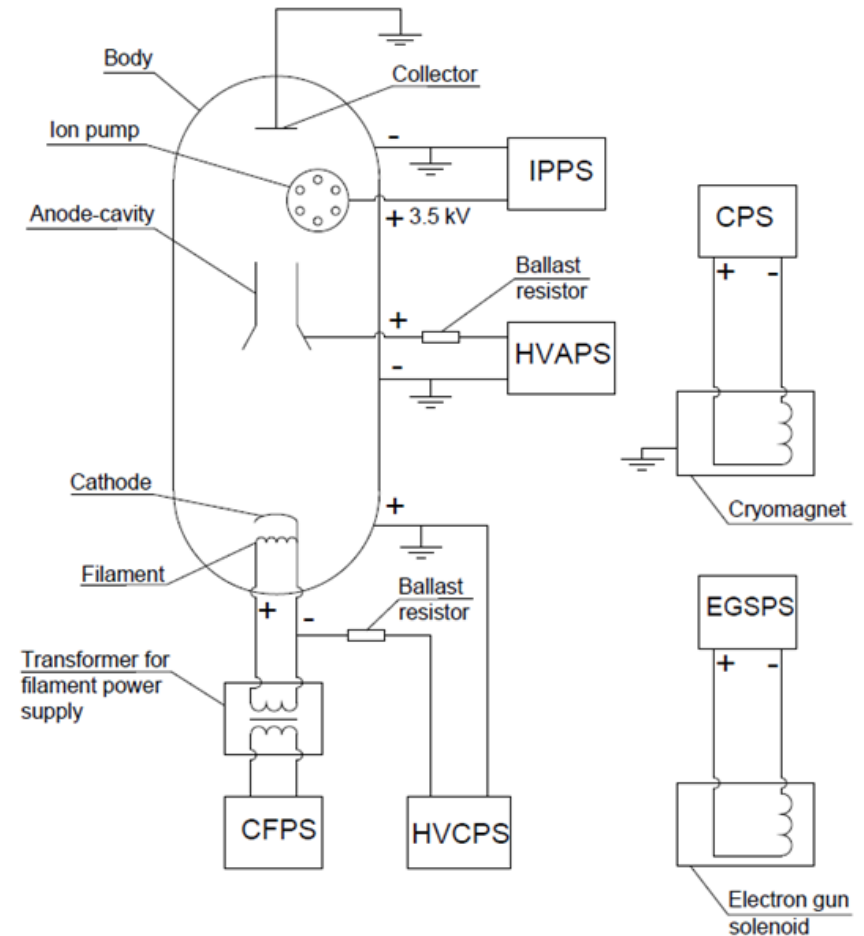

Magnetic System

Cryogen-free magnet (JASTEC, Inc . Japan)



The system based on JMTD 4T140 liquid helium free magnet
(up to 4 T, warm bore \varnothing 140 mm, operating magnetic field \sim 2T)

FAT carried out with GYCOM magnet

High-Voltage Power Supplies



Cathode and Anode High-Voltage Power Supplies Rack

*(IAP RAS High-Voltage Equipment Group,
E.A.Kopelovich)*

CHVPS:

25kV/2.4A, CW and Pulse modes, negative polarity
2ms – DC, rise/fall 50 mks

AHVPS:

15kV/0.1A, CW and Pulse modes, positive polarity
2ms – DC, rise/fall 2 mks

Cathode and anode power supplies provide synchronous operation to guarantee safe and correct operation of gyrotron with depressed collector.

High-Voltage Power Supplies

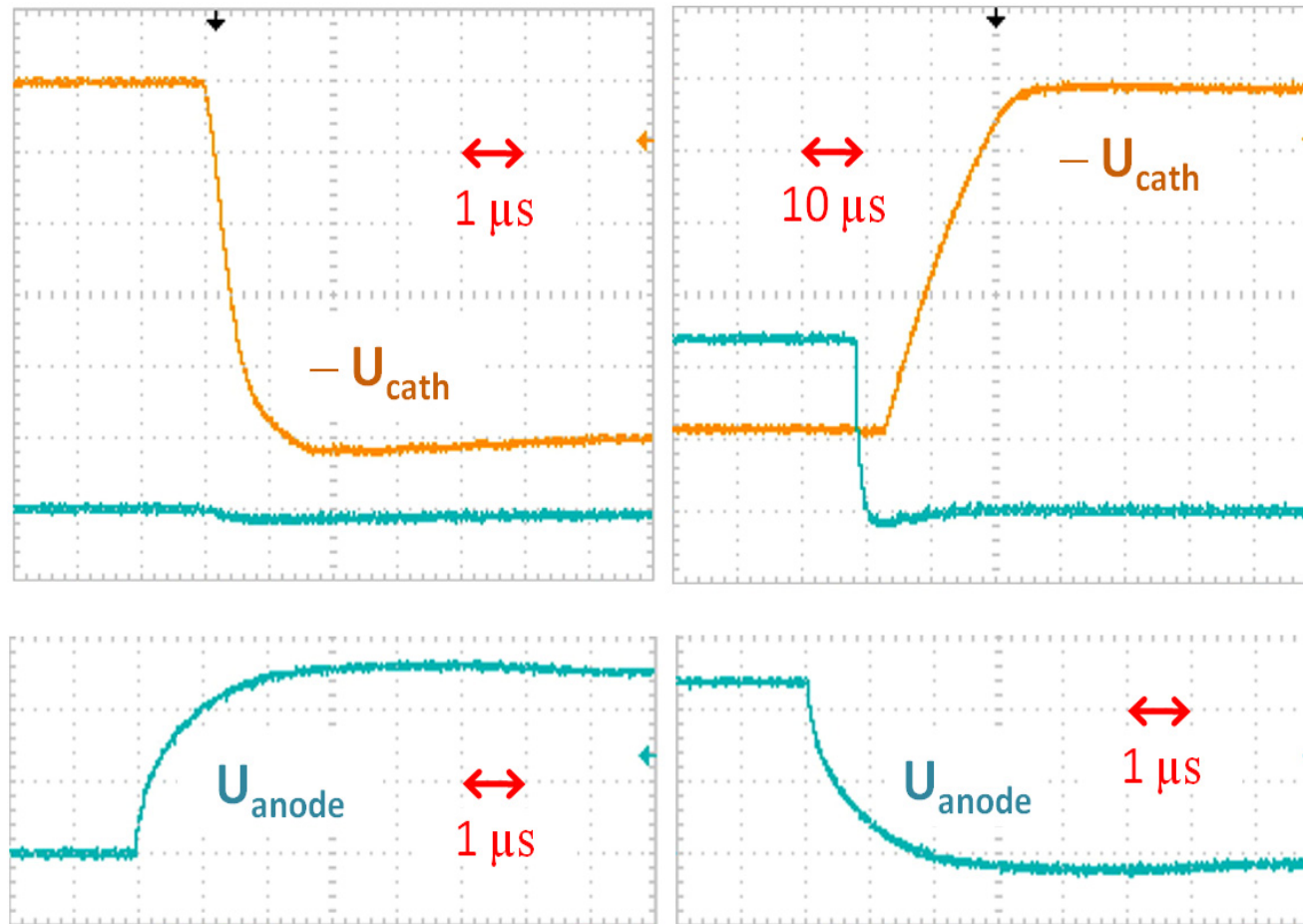

Pulse mode: 5 – 200 ms pulses with 1 – 10 Hz repetition rate

Cathode and anode power supplies provide synchronous operation for safe and correct operation of the gyrotron with depressed collector.

Gyrotron pulse operation

DSO-X 3024A, MY51360549: Tue Feb 14 16:12:31 2017

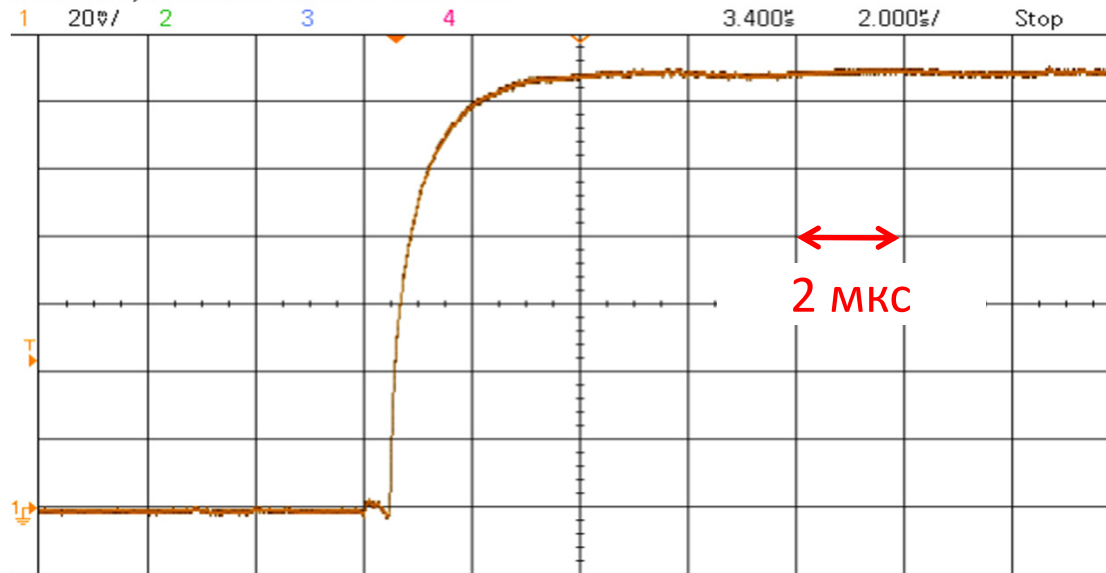

5 – 200 ms
1 – 10 Hz

Recall Menu

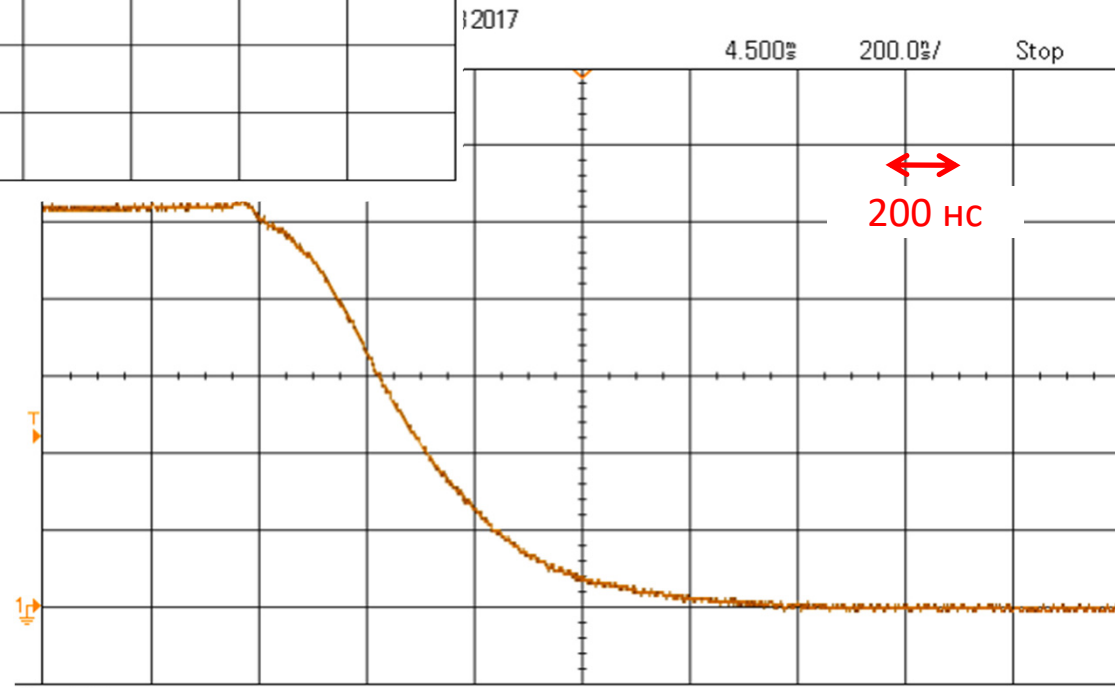

Assembling of the setup

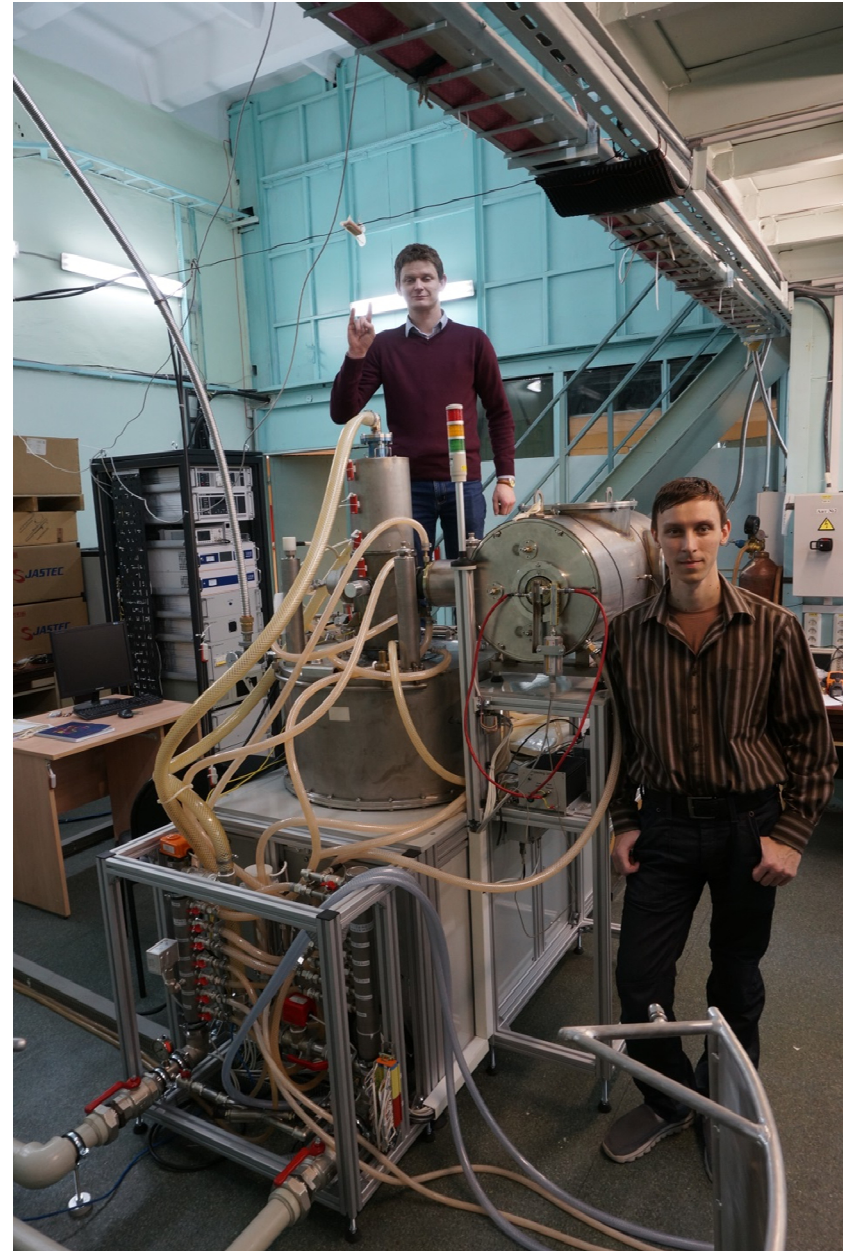

Output power and spectrum

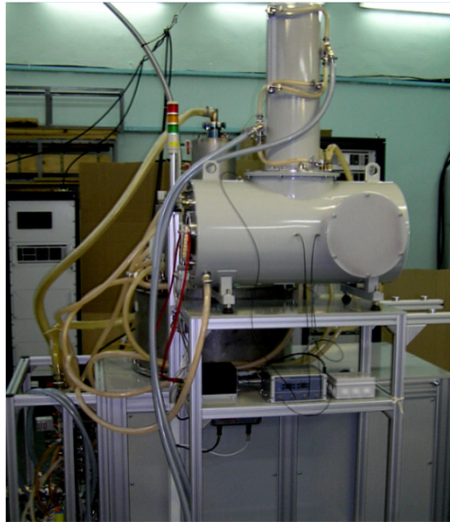

$P_{out} = 0 \dots 26 \text{ kW}$
 $\eta \approx 50\%$

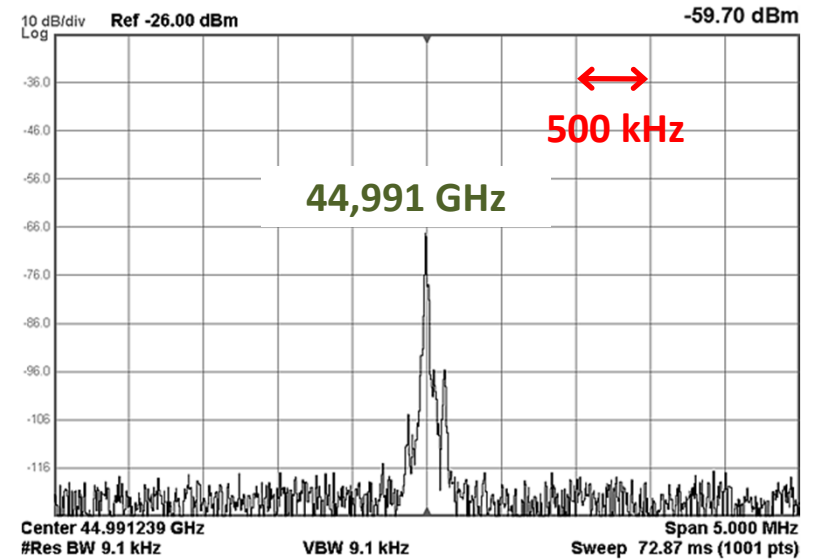
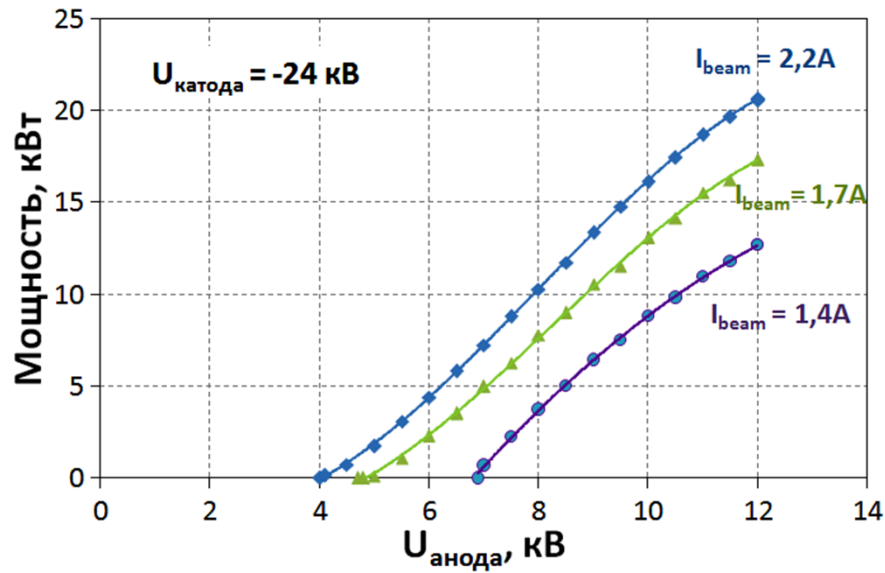
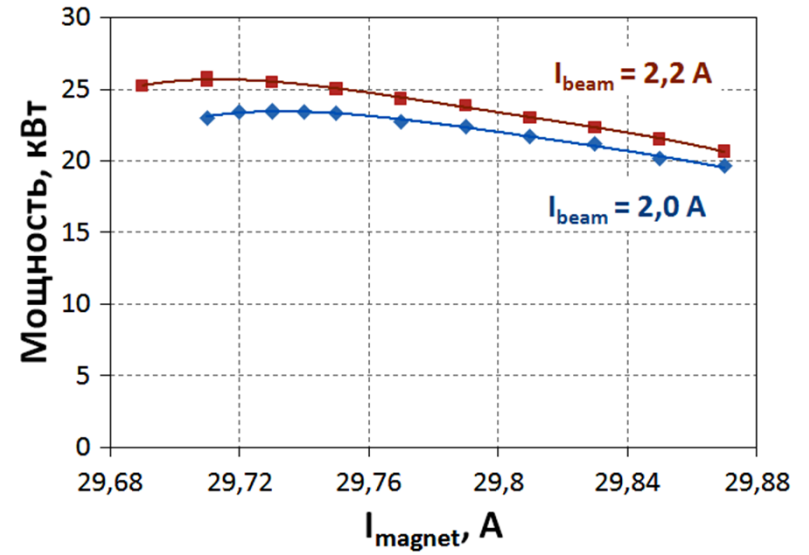

Power Measurement System

Bi-directional couplers for monitoring and measuring the incident and reflected microwave power are mounted on the MOU mirrors.

Attenuated microwave power for the incident and reflected waves is coupled to the rectangular waveguides through a set of the regular located circular holes of small diameter.

Additional directional coupler is set in the channel of incident power. It divides the signal to 2 channels, one of them is connected to power meter, which is used for measuring power in CW mode, another channel is connected to microwave detector, which is used in pulsed mode.

Additional mirror (rotary switch) is placed between the main MOU mirrors and reflects the gyrotron radiation to the calorimetric dummy load.

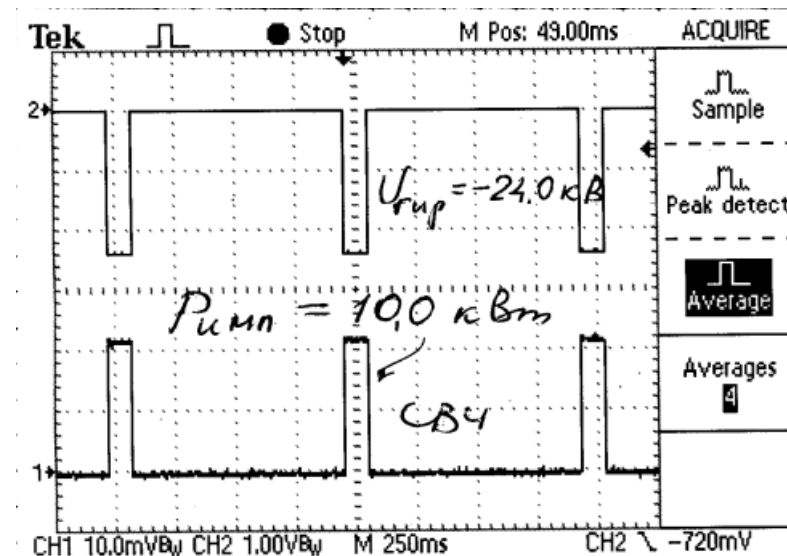

Automation & Control

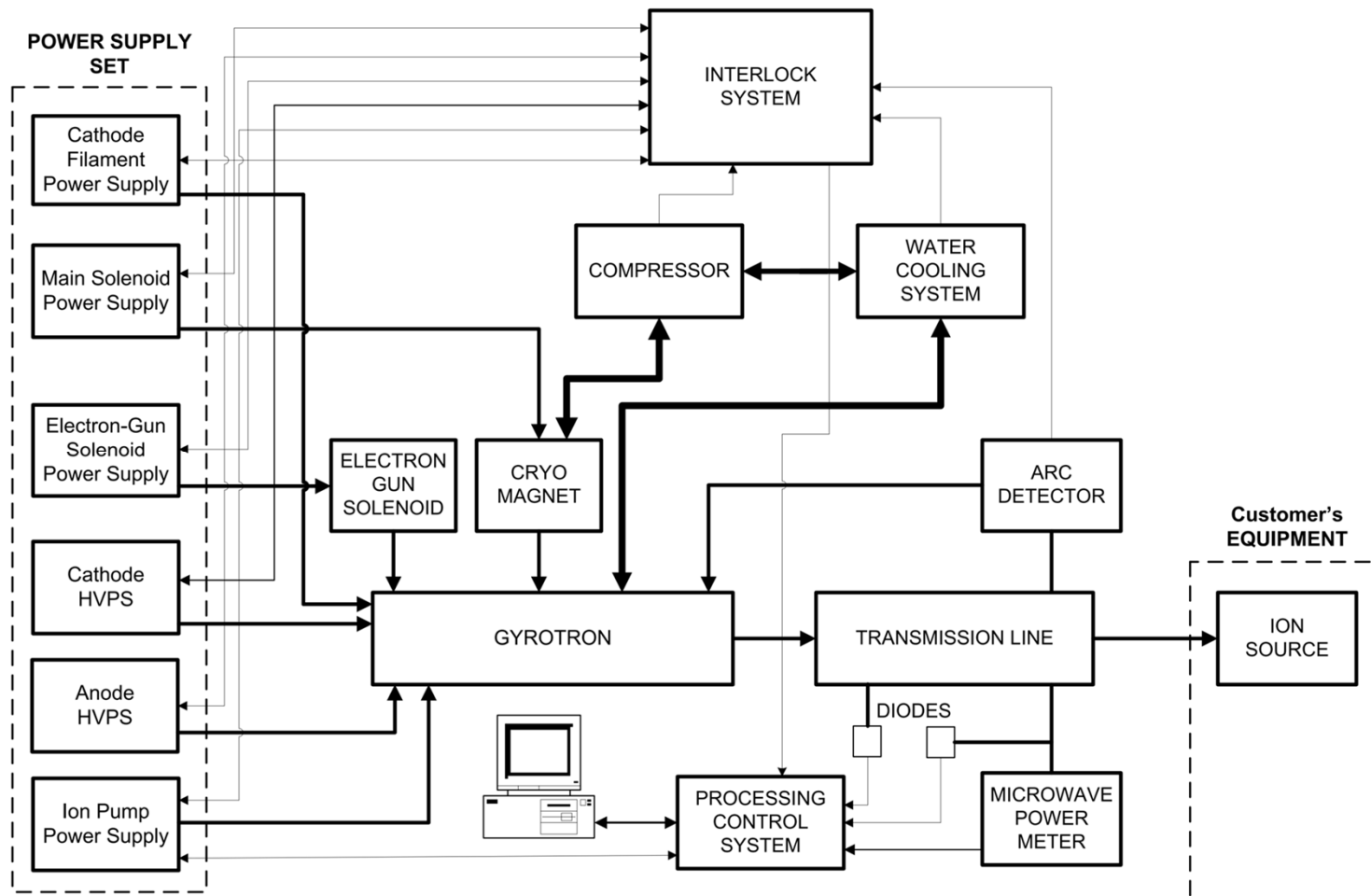

The setup is fully equipped with the automated control, data acquisition and safety interlocks systems that guarantee convenient and safe remote and local operation.



Automation & Control

The Client GUIs displaying the indicator panel of the Interlock System and the results of automatic microwave power control.

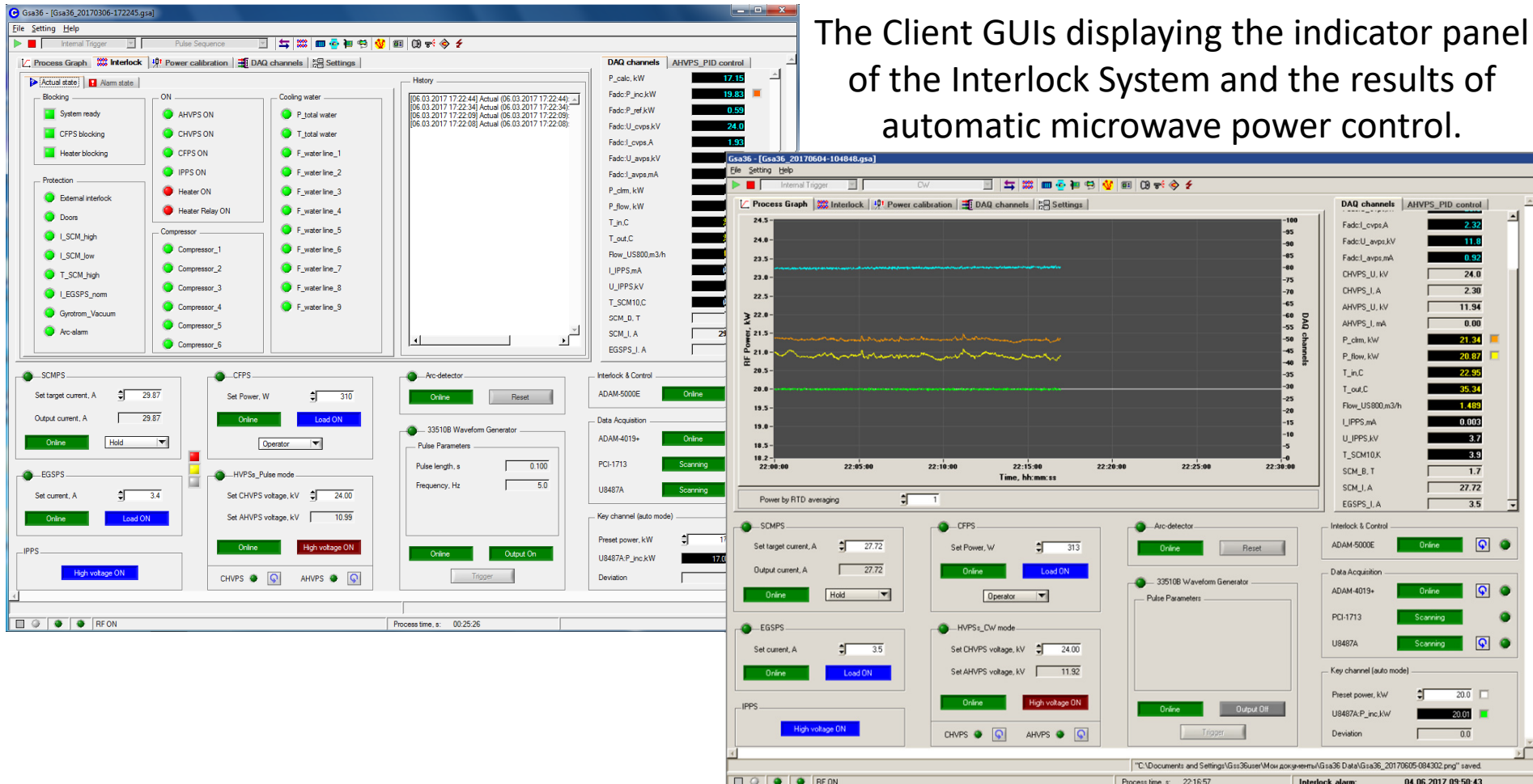

The setup have possibility of integration into ion accelerator facility using EPICS Channel Access network protocol-based interaction with server software.



14th International Conference
on Heavy Ion Accelerator Technology
Lanzhou, China, October 22-26, 2018

Transmission Line

- 4 reflectors
- 66mm BN window
- down taper
- synthesized mode converter

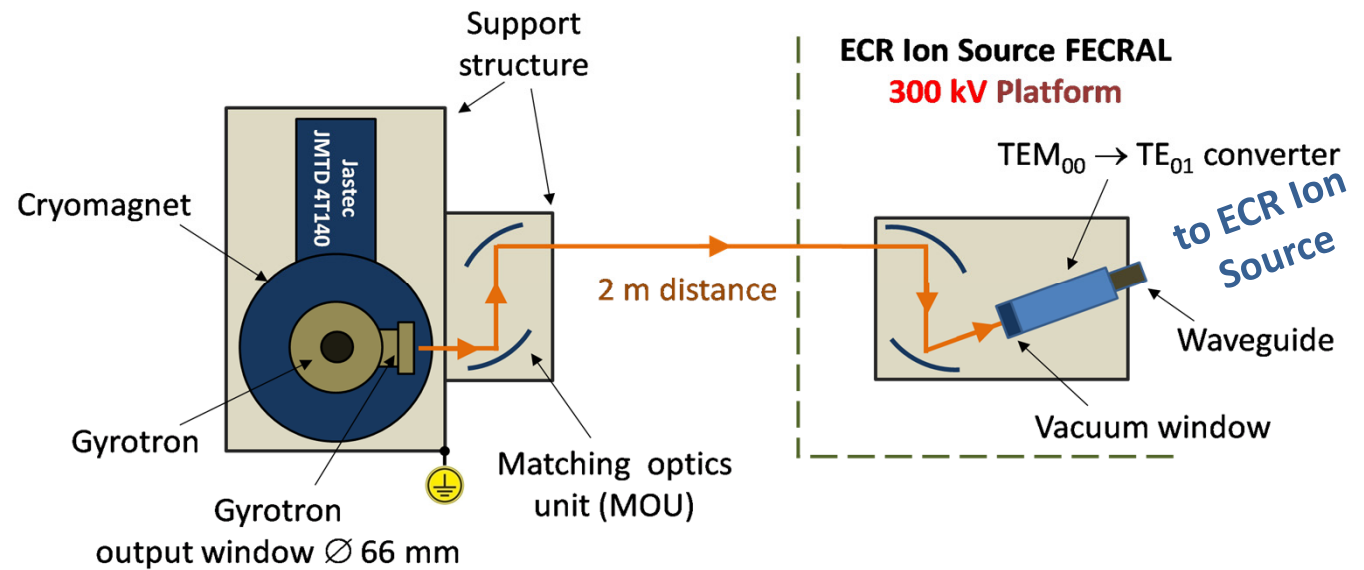

Wave beam transmitting part

- 2 (of 4) reflectors
- 66 mm BN window
- Down taper to 22 mm
- Mode converter

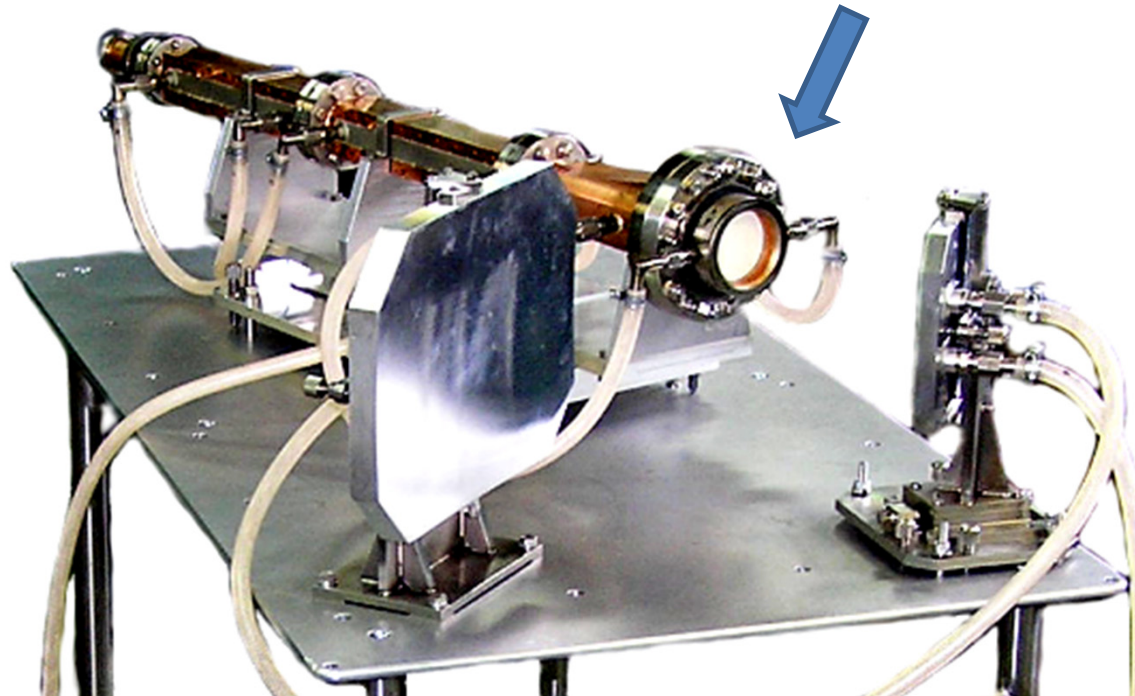
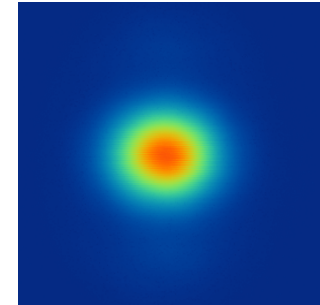

Synthesized Oversized Mode Converter

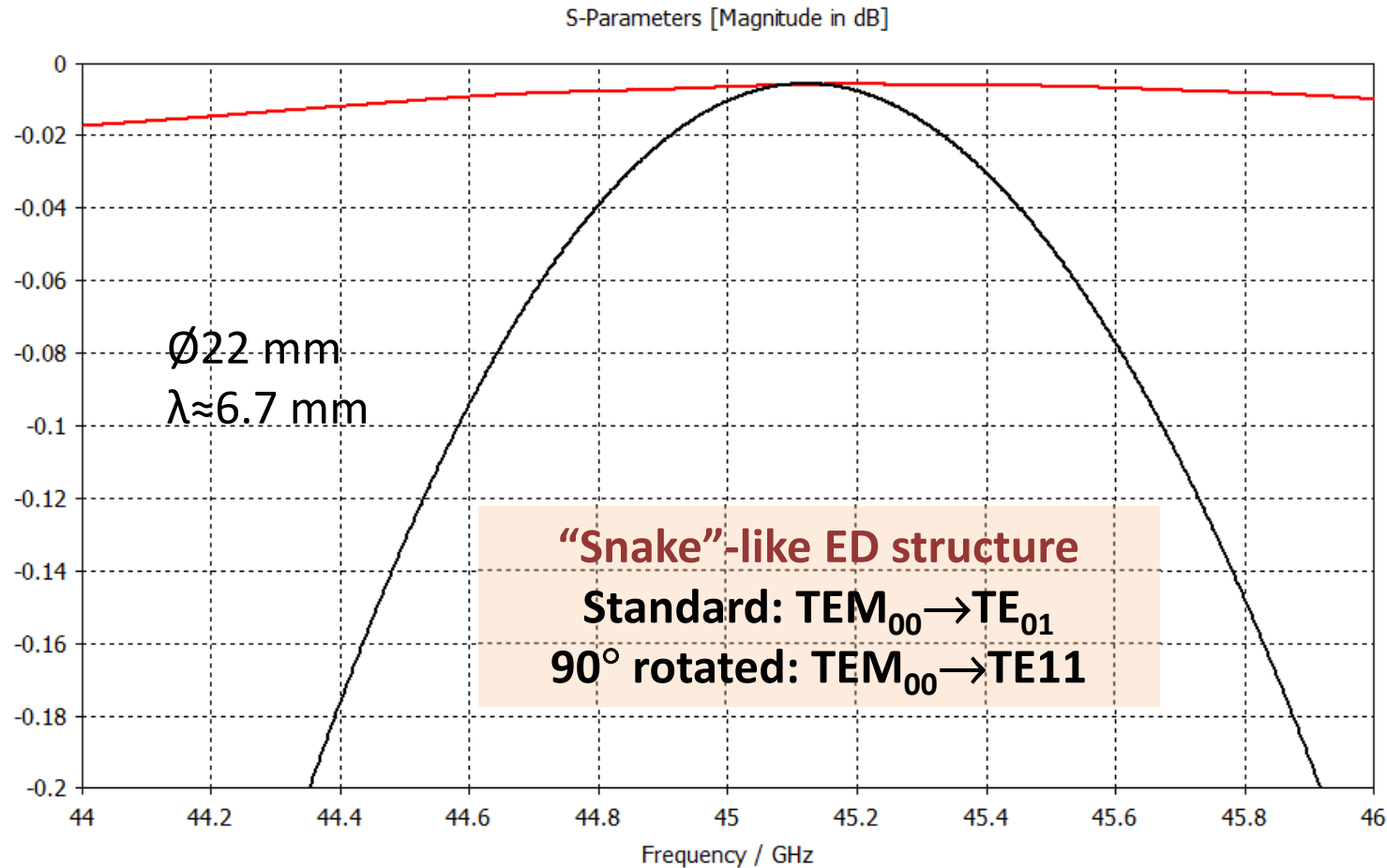

**< 0.2%
mode
admixture**

Frequency characteristics:

$\text{TEM}_{00} \rightarrow \text{TE}_{01}$
 $\text{TEM}_{00} \rightarrow \text{TE}_{11}$



Transmission of microwaves to plasma chamber

(quasi-optical transmission, window, mode converter)

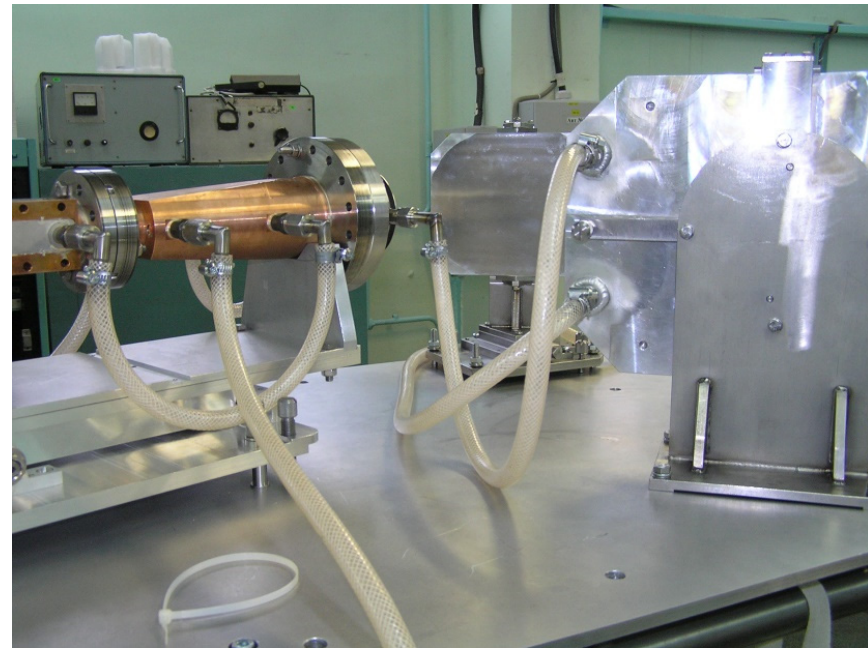

TEM00 – TE01/TE11 converter parts

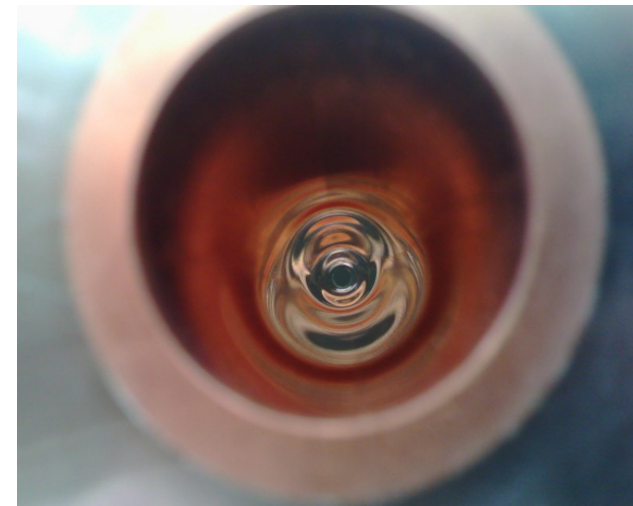
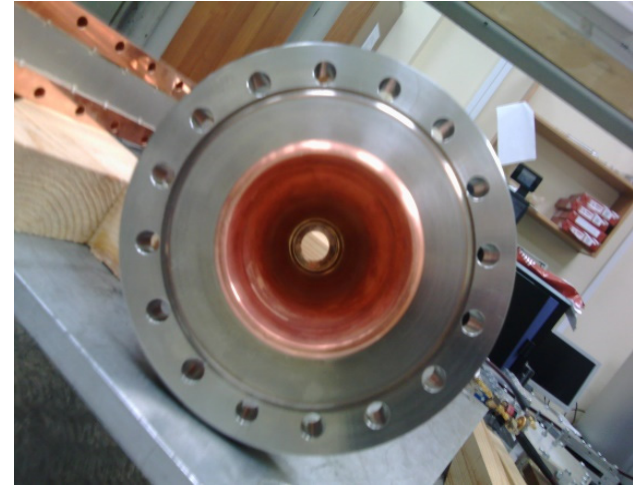
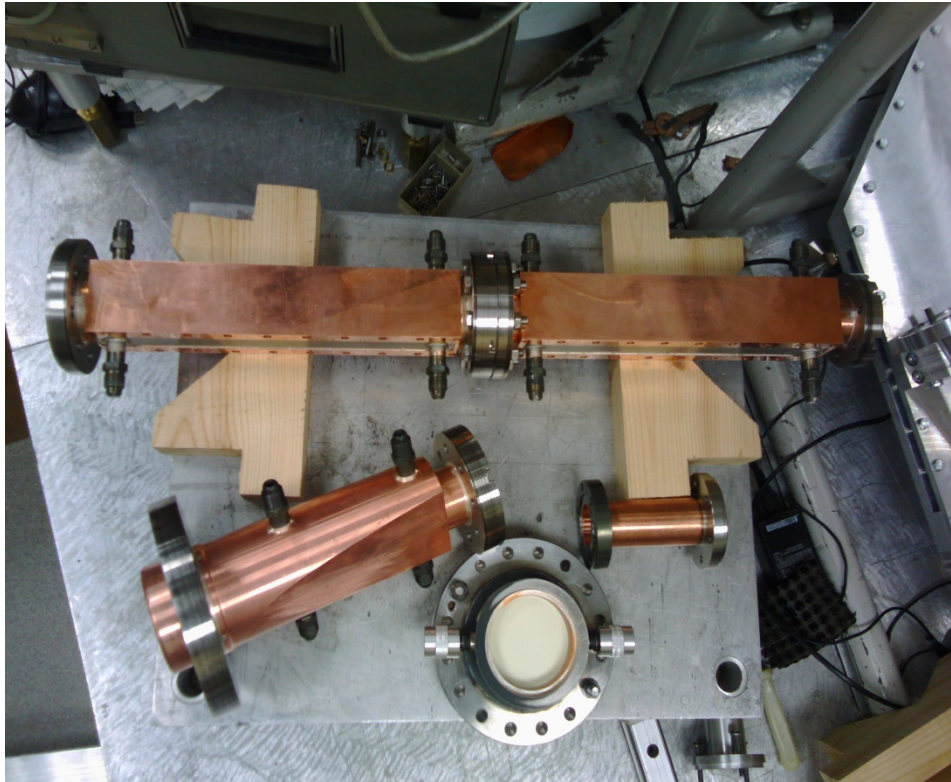

TEM00 – TE01/TE11 mode converter

Simulations of the converter

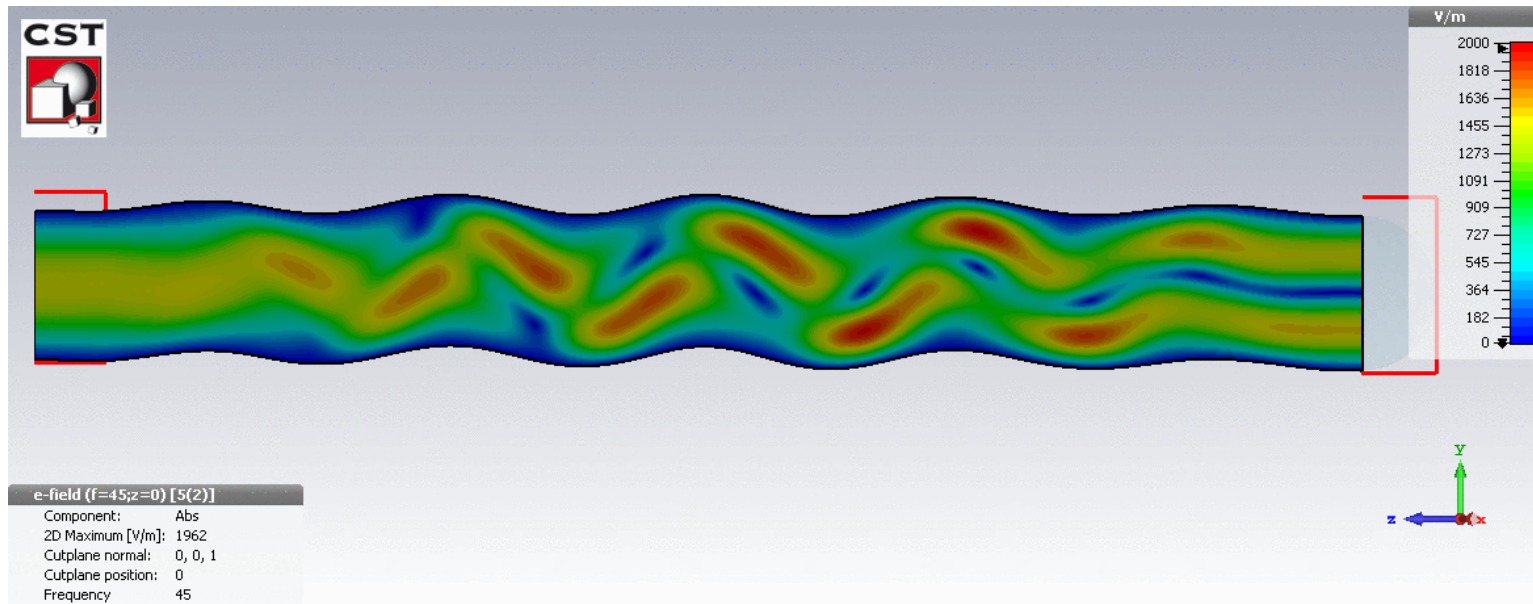

Fabricated inner surface of the mode converter.



Field structure at the output of mode converter: simple switching of output mode is obtained by 90 degree rotation of corrugated section

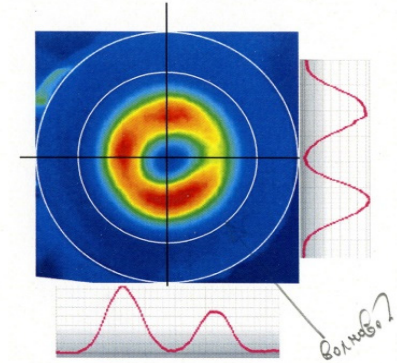
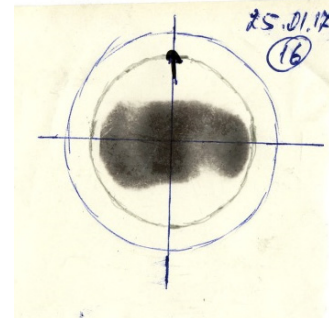
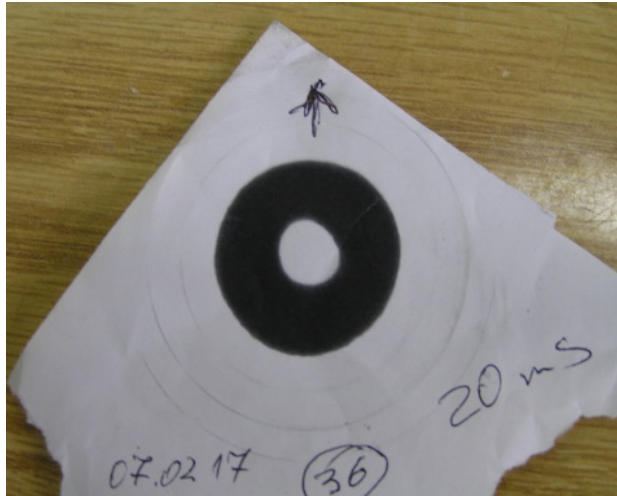

Burn patterns on the paper for TE₀₁ and TE₁₁ output modes corresponding to different axial orientations of the converter.

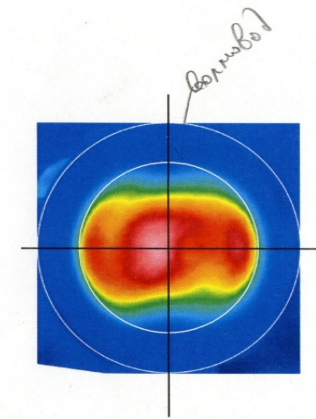

> 98% mode purity

Infrared
Camera
images

Summary

The series of gyrotron-based setups for technological applications has been developed at IAP RAS jointly with GYCOM Ltd. and are currently used for research and microwave processing. The systems have proved to be a versatile, flexible, and user-friendly tool for various applications.





Institute of Applied Physics, RAS



GYCOM Ltd.

**THANK YOU
FOR YOUR ATTENTION!**

